

CONTENTS

I. EXECUTIVE ORDERS

EWE 93-37—Amends Executive Order No. EWE 93-36.....	1504
EWE 93-38—Establishes a Telecommunication Task Force.....	1504
EWE 93-39—Amends Executive Order No. EWE 93-8.....	1505
EWE 93-40—Bond Allocation by the Port of Iberia District for Certification of Indebtedness	1505
EWE 93-41—Bond Allocation by Industrial Development Board of the Parish of Calcasieu, Inc. for CITGO Petroleum Corporation.....	1506
EWE 93-42—Bond Allocation by Industrial District No. 3 of the Parish of West Baton Rouge for Dow Chemical Corporation ..	1507
EWE 93-43—Bond Allocation by the Parish of Natchitoches for Willamette Industries, Inc.	1507
EWE 93-44—Bond Allocation by the Parish of St. Charles for Louisiana Power & Light Company	1508
EWE 93-45—Bond Allocation by the Louisiana Housing Finance Agency for Tall Timbers Apartments.....	1508

II. EMERGENCY RULES

Economic Development:

Racing Commission—Equipment for Jockeys (LAC 35:IX.9503).....	1509
No Medication in 2-Year-Olds (LAC 35:I.1722).....	1510
Permitted Medication for 2-Year-Olds (LAC 35:I.1503).....	1510

Education:

Board of Elementary and Secondary—Teacher Tuition Exemption FY 1993-94	1510
--	------

Environmental Quality:

Office of the Secretary—Importation of Foreign Hazardous Waste (LAC 33:V.1101, 1113)(HW38E).....	1510
--	------

Health and Hospitals:

Office of Management and Finance—Reimbursement for Inpatient Hospital Services in Rural Hospitals	1512
Office of the Secretary—Annual Service Agreement—Louisiana Health Care Authority (LHCA)	1513
Bureau of Health Services Financing—Disproportionate Share Payment—Inpatient Pool	1514
Bureau of Protective Services—Referral and Investigation Procedures (LAC 48:17101-17125).....	1516

Insurance:

Commissioner of Insurance—Regulation 51—Individual Health Insurance Rating Requirements	1520
Regulation 52—Small Group Health Insurance Rating Requirements.....	1521

Labor:

Office of Labor—Community Services Block Grant (LAC 40:XVII.Chapters 29 and 49).....	1522
--	------

Public Safety and Corrections:

Board of Pardons—Sex Offenders (LAC 22:IX)	1524
Office of Alcoholic Beverage Control—Fairs, Festivals, and Special Event Permits (LAC 55:VII.323)	1526

Revenue and Taxation:

Sales Tax Division—Automobile Rentals; Allocation of Use Tax (LAC 61:I.4307).....	1526
---	------

Social Services:

Office of Family Support—Child Support Non-IV-D Program (LAC 67:III.Chapter 28).....	1527
--	------

State:

Office of Uniform Commercial Code—Central Registry Master List Program (LAC 10:XIX.321).....	1528
--	------

Treasury:

Board of Trustees of the State Employees Group Benefits Program—Plan Document.....	1528
--	------

Wildlife and Fisheries:

Wildlife and Fisheries Commission—Commercial Fisherman's Sales Report Forms (LAC 76:VII.203)	1529
--	------

This public document was published at a total cost of \$4,575.00. 1,050 copies of this document were published in this monthly printing at a cost of \$2,575.00. The total cost of all printings of this document including reprints is \$4,575.00. This document was published by Moran Printing, Inc., 5425 Florida Blvd., Baton Rouge, LA 70806, as a service to the state agencies in keeping them cognizant of the new rules and regulations under the authority of R.S. 49:950-971. This material was printed in accordance with standards for printing by state agencies established pursuant to R.S. 43:31. Printing of this material was purchased in accordance with the provisions of Title 43 of the Louisiana Revised Statutes.

The Office of the State Register provides auxiliary aids for the *Louisiana Register* for visually impaired individuals. By appointment, oral presentation of the *Register* is available at the Office of the State Register, or an audio cassette tape of requested sections of the *Register* can be provided for the cost incurred by the Office of the State Register in producing such a tape. For more information contact the Office of the State Register.

Dealer Receipt Forms (LAC 76:VII.201).....	1529
Fall Shrimp Season Closure.....	1529
Red Snapper Commercial Fishery Closure.....	1530
III. RULES	
Agriculture and Forestry:	
Office of Agro-Consumer Services, Division of Weights and Measures—Weights and Measures (LAC 7:XXXV.Chapter 175)	1530
Culture, Recreation and Tourism	
Office of Cultural Development, Division of the Arts—Mission and Grant Applicant Information (LAC 25:I.Chapter 3).....	1536
Office of State Parks—Overnight and Day Use (LAC 25:IX.505).....	1536
Economic Development:	
Board of Examiners of Certified Shorthand Reporters—Certification, Examinations, Continuing Education, Hearings and Fees (LAC 46:XXI.Chapters 1-9).....	1537
Office of Commerce and Industry, Division of Financial Incentives—Biomedical Research and Development Park Program (LAC 13:I.Chapter 41).....	1541
University Research and Development Parks Program (LAC 13:I.Chapter 43).....	1543
Office of Financial Institutions—Fees and Assessments (LAC 10:I.110, 201, 203 and LAC 10:V.5101).....	1546
Racing Commission—Health Certificate Necessary (LAC 35:I.1303).....	1548
Education:	
Board of Elementary and Secondary Education—Bulletin 1921—Annual Special Education Program and Bulletin 1927—Pre-School Grant Application (LAC 28:I.937).....	1548
Bulletin 1934—Starting Points Preschool Regulations (LAC 28:I.906).....	1549
Child and Adult Care Food Program (LAC 28:I.944).....	1549
Technical Institutes Refund Policy (LAC 28:I.1523).....	1550
Technical Institutes Tuition Fees (LAC 28:I.1523).....	1551
Board of Regents—Registration, Licensure and Consumer Protection (LAC 28:IX.Chapters 1, 3, and 5).....	1551
Proprietary School Commission—Annual Licensure Renewal Fee (PSC-12, Appendix L) (LAC 28:III).....	1555
Initial Licensure Fee and Annual License Renewal Fee Schedule (LAC 28:III).....	1556
Student Protection Fund Claim Form (LAC 28:III).....	1556
Student Protection Fund Policies (LAC 28:III).....	1559
Surety Bond Claim Form (LAC 28:III).....	1560
Student Financial Assistance Commission, Office of Student Financial Assistance—Late Guarantee (LAC 28:V).....	1562
LEO Alternative Employer Repayment (LAC 28:V).....	1563
Tuition Award Funding Procedure (LAC 28:V).....	1563
Environmental Quality:	
Office of Air Quality and Radiation Protection, Air Quality Division—Filling of Gasoline Storage Vessels; Control of Emissions from the Chemical Woodpulping Industry (LAC 33:III,2131, 2301) (AQ79).....	1564
Radiation Protection Division—Fee System of the Air Quality Control Program (LAC 33:III.223) (AQ77) (Originally proposed as §6523).....	1564
Governor's Office:	
Office of Veterans Affairs—State Aid Program (LAC 4:VII.917).....	1565
Patient's Compensation Fund Oversight Board—Future Medical Care and Related Benefits (LAC 37:III.Chapter 19).....	1566
Health and Hospitals:	
Board of Licensed Professional Vocational Rehabilitation Counselors—License, Practice, License Renewal, Definitions and Reciprocity (LAC LXXXVI.503, 703, 705 and 707).....	1569
Board of Nursing—Licensure by Examination/Endorsement; Temporary Permits (LAC 46:XLVII.3349, 3351, 3353).....	1572
Board of Optometry Examiners—Continuing Education; License to Practice (LAC 46:LI.503).....	1573
Office of Public Health—Authorization of Testing of a New Method for Identifying Congenital Syphilis in Newborns.....	1575
Death Certificate Preparation (LAC 48:V.12307).....	1575
Office of the Secretary, Bureau of Health Services Financing—Nurse Aide Registry.....	1579
Pharmacy Lock-In Program.....	1579
Medical Disclosure Panel—Informed Consent (LAC 48:I.Chapter 23).....	1581
Insurance:	
Commissioner of Insurance—Regulation 45—Filing of Affirmative Action Plans.....	1581
Labor:	
Office of Labor—Job Training Partnership Act (LAC 40:XIII.Chapter 1).....	1581
Plumbing Board—Licensing and Renewal Fee Changes (LAC 46:LV.Chapter 3).....	1593
Revenue and Taxation:	
Office of the Secretary—Timely Filing Date (LAC 61:I.4903).....	1594
Transportation and Development:	
Office of General Counsel, Crescent City Connection Division—Toll Exemptions—Firemen (LAC 70:I.507).....	1594
Toll Exemptions—Students (LAC 70:I.509).....	1595
Office of the Secretary, Public Transportation Section—Tourist Oriented Directional Signs (LAC 70:III.Chapter 2).....	1596
Treasury:	
Board of Trustees of the Teachers' Retirement System—Deferred Retirement Option Plan (DROP).....	1601
Renunciation of Benefits.....	1602

IV. NOTICES OF INTENT

Economic Development:

Board of Examiners of Certified Shorthand Reporters—Continuing Education Credits (LAC 46:XXI.603).....	1603
Reportorial Services (LAC 46:XXI.Chapter 11)	1603
Used Motor Vehicle and Parts Commission—Identification Cards (LAC 46:V.2801).....	1604

Education:

Board of Elementary and Secondary Education—Bulletin 746—Standards for Certification of School Personnel— Special Education	1605
Bulletin 746—Standards for Certification of School Personnel—Temporary Employment Permits (LAC 28:I.903)	1606
Bulletin 746—Standards for Certification of School Personnel—Temporary Teaching Assignments	1606
Bulletin 1868—BESE Personnel Manual.....	1606
Bulletin 1903—Dyslexic Student Education.....	1608
Hiring of Noncertified School Personnel (LAC 28:I.903).....	1609
Student Financial Assistance Commission, Office of Student Financial Assistance—Electronic Funds Transfer (EFT)(LAC 28:V)	1610

Environmental Quality:

Office of Air Quality and Radiation Protection, Air Quality Division—Benzene Waste Operations (LAC 33:III.5139)(AQ73)	1613
Chemical Accident Prevention and Fees (LAC 33:III.Chapters 2 and 59)(AQ31)	1614
Emission Reduction Credits Banking (LAC 33:III.Chapter 6)(AQ85).....	1615
Reasonable Further Progress (LAC 33:III.2120)(AQ86).....	1616
Standards of Performance for New Stationary Sources (LAC 33:III.Chapter 31)(AQ69)	1617
Office of Solid and Hazardous Waste, Underground Storage Tank Division—UST Registration (LAC 33:XI.301)(UT05L)	1618
UST Registration (Federal) (LAC 33:XI.301)(UT05F).....	1619
Office of Water Resources, Water Quality Management Division—Surface Water Quality Standards (LAC 33:IX.Chapter 11)(WP12)	1620

Governor's Office:

Office of Veteran's Affairs—Merchant Marine Bonus (LAC 4:VII.915).....	1621
Patient's Compensation Fund Oversight Board—Payment of Surcharges (LAC 37:III.711-713).....	1622

Health and Hospitals:

Board of Examiners of Professional Counselors—Declaration of Practices and Procedures (LAC 46:LX.Chapter 21, Appendix).....	1623
Office of Public Health—Tuberculosis Control Regulations	1625
Office of the Secretary—DHH/LHCA Annual Service Agreement.	1625
Bureau of Health Services Financing—Drug Screening and Certification Program	1626
Facility Need Review—Downsizing ICF/MR Facilities.....	1627
Medicaid Pediatric Immunizations Provisions.....	1628
Transfers of Assets.....	1629
Bureau of Protective Services—Referral and Investigation (LAC 48:I.Chapter 17).....	1631
Commission on Perinatal Care and Prevention of Infant Mortality—Obstetrical/Neonatal Levels of Care	1631
Informed Consent (LAC 48:I.2315-2323).....	1635
Medical Disclosure Panel—Informed Consent (LAC48:I.2324).....	1636

Insurance:

Commissioner of Insurance—Regulation 49—Billing Audit Guidelines.....	1639
Regulation 51—Individual Health Insurance Rating Requirements.....	1643
Regulation 52—Small Group Health Insurance Rating Requirements	1643

Public Safety and Corrections:

Office of State Police—Charitable Bingo, Keno, Raffle (LAC 42:I.Chapters 17, 19 and 22).....	1644
--	------

Revenue and Taxation:

Sales Tax Division—Automobile Rentals; Allocation of Use Tax (LAC 61:I.4307).....	1644
---	------

Social Services:

Office of Rehabilitation Services—Policy Manual (LAC 67:VII.101).....	1645
---	------

Transportation and Development:

Utility and Permit Section—Standards Manual—Facilities in Right-of-Way (LAC 70:III.Chapter 13)	1645
--	------

Treasury:

Bond Commission—Disclosure of Agreements between Financial Professionals for Negotiated Transactions.....	1646
---	------

V. POTPOURRI

Economic Development:

Office of Financial Institutions—Judicial Interest Rate—1994.....	1647
Public Hearing—CAPCOs	1648

Health and Hospitals:

Office of the Secretary, Bureau of Health Services Financing—Disproportionate Share Hospital Reimbursement—Indigent Care.....	1648
Nursing Facility—Infectious Disease	1649

Insurance:

Commissioner of Insurance—Rule 10 Hearing	1649
---	------

Natural Resources:

Office of the Secretary, Fishermen's Gear Compensation Fund—Claims	1649
--	------

Social Services:

Office of Community Services—Weatherization Assistance Program—Public Hearing.	1650
---	------

EXECUTIVE ORDERS

EXECUTIVE ORDER EWE 93-37

WHEREAS: Executive Order No. EWE 93-36 directed the Secretary of the Louisiana Department of Transportation and Development to issue a special harvest season permit to the operators of vehicles loaded with sugarcane; and

WHEREAS: it is necessary to amend Executive Order No. EWE 93-36 to change the effective date;

NOW, THEREFORE, I, EDWIN W. EDWARDS, Governor of the State of Louisiana, by virtue of the authority vested in me by the Constitution and laws of the State of Louisiana, do hereby amend Section 2 of Executive Order No. EWE 93-36 by changing the effective date to October 1, 1993.

IN WITNESS WHEREOF, I have hereunto set my hand officially and caused to be affixed the Great Seal of the State of Louisiana, at the Capitol, in the City of Baton Rouge, Louisiana, on this 28th day of October, 1993.

Edwin Edwards
Governor

ATTEST BY
THE GOVERNOR
Fox McKeithen
Secretary of State

EXECUTIVE ORDER EWE 93-38

WHEREAS: the Federal Interstate Highway Program was enacted by Congress to provide a twenty-first century infrastructure for the transportation of its citizens and commodities; and

WHEREAS: the Governor believes that the need for a telecommunications superhighway should be studied in order to provide a state-of-the-art infrastructure for the transportation of telecommunications including information services, distance learning, telemedicine, telecommuting and many others which may not have been identified; and

WHEREAS: telecommunications offers solutions in the fields of education, transportation, health care, governmental information services, law enforcement and other areas. Each of these needs should be considered in order to design an infrastructure which can satisfy them; and

WHEREAS: the objective is to develop a plan which provides the flexibility to deploy the necessary technology at a price consumers can afford, state regulators can approve and the private sector can deliver. The ideal solution will attract industry and benefit consumers with state-of-the-art services which are universally available at affordable costs.

NOW, THEREFORE, I, EDWIN W. EDWARDS, Governor of the State of Louisiana, by virtue of the authority vested in me by the Constitution and laws of the State of Louisiana, do hereby establish a special Louisiana Telecommunication Task Force to develop a comprehensive telecommunications plan for the State by July 1, 1994 and to make recommendations to the legislature thereon, and do hereby order and direct as follows:

SECTION 1: The Louisiana Telecommunication Task Force shall be composed of the following membership, along with a member to be appointed by the Louisiana State Senate and a member appointed by the Louisiana House of Representatives. The co-chairmen are the Chairman of the Louisiana Public Service Commission and the Executive Director of the Governor's Office of Rural Development.

1. Mr. Larry Henning, President, Louisiana Telephone Association
2. Mr. Elton King, President, South Central Bell
3. Ms. Kathleen Blanco, Chairman, Louisiana Public Service Commission
4. Mr. Paul Gravel, Managing Director, Louisiana Public Facilities Authority
5. Dr. Fritz McCameron, Dean, Division of Continuing Education, Louisiana State University
6. Mr. Bud Lanier, Director, Office of Telecommunications Management
7. Dr. Robert Cline, Director of the Center for Telecommunications Studies, University of Southwestern Louisiana
8. Dr. Raymond Arveson, Superintendent, Louisiana Department of Education
9. Dr. William Cherry, Chief Executive Officer, Louisiana Health Care Authority
10. Mr. Bill Peacock, AT&T
11. Disability Representative
12. Mr. Mike Naumann, State Manager, TCI of Louisiana
13. Robert S. Daniels, Dean, Louisiana State University School of Medicine
14. Mr. Tom Jacques, State Librarian
15. Ms. Beth Courtney, Louisiana Public Broadcasting
16. Mr. Allen Doescher, Assistant Commissioner for Technical Services and Communications, Division of Administration
17. Mr. Jim Clinton, President, Louisiana Partnership for Technology and Innovation
18. Mr. Paul Keller, Executive Director, Governor's Office of Rural Development
19. Mr. Mike Niggli, Senior Vice President of Marketing, Entergy Corporation
20. Mr. Dan Borne, President, Louisiana Chemical Industry Council
21. Mr. Kevin Reilly, Secretary, Louisiana Department of Economic Development
22. Albert I. Donovan, Jr., Executive Counsel to the Governor
23. Carolyn Sanders, UNO
24. Sally Clausen, Governor's Education Advisor
25. Dr. Gordon Mueller, Director of Extension Research and Technology Park, University of New Orleans

EXECUTIVE ORDER EWE 93-39

26. Mike Tift, Director of The City Council Utilities Regulatory Office, City of New Orleans and Deputy City Attorney.

SECTION 2: The joint committee is authorized to accept any money from any source, public or private, to be expended in implementing its duties under this resolution.

SECTION 3: The joint committee shall not hire any state employee, but shall utilize the clerical and legal staff already employed by the state.

SECTION 4: To develop a comprehensive telecommunications plan for the state, the Task Force should identify all of the diverse needs of the state and its citizens, analyze existing facilities and systems, and design an ultimate infrastructure. In order to identify needs, a broad array of telecommunications users and providers should be surveyed. Regulators, educators, transportation officials, health care providers, prison commissions, local exchange telephone companies, interchange carriers, computer companies, broadcasters, cable companies, electric power associations and many others shall be invited to participate in the identification of long and short term needs.

SECTION 5: Existing facilities and systems includes cooper cables, coaxial cables, fiber optic cables, microwave radio systems, AM and FM radio transmission facilities, satellite systems, cellular and mobile systems. While all these facilities are available to meet specific needs, there needs to be an integrated approach to provide efficient, cost effective use of the total telecommunications infrastructure.

SECTION 6: The Task Force shall recommend the financial resources to be used to implement the plan over the appropriate timetable. The task force shall review laws relating to the telecommunications industry and shall make recommendations to remove any barriers which would prevent or delay implementation of the plan.

SECTION 7: The provisions of this Executive Order are effective upon signature and shall remain in effect until amended, modified, or rescinded by operation of law.

IN WITNESS WHEREOF, I have hereunto set my hand officially and caused to be affixed the Great Seal of the State of Louisiana, at the Capitol, in the City of Baton Rouge, Louisiana, on this 10th day of November, 1993.

Edwin Edwards
Governor

ATTEST BY
THE GOVERNOR
Fox McKeithen
Secretary of State

WHEREAS: Executive Order No. EWE 93-8 created and established the Louisiana Post Secondary Review Commission within the Executive Department, Office of the Governor; and

WHEREAS: it is necessary to amend Executive Order No. EWE 93-8 to add one additional member;

NOW, THEREFORE, I, EDWIN W. EDWARDS, Governor of the State of Louisiana, by virtue of the authority vested in me by the Constitution and laws of the State of Louisiana, do hereby amend Section 7 of Executive Order No. EWE 93-8 as follows:

SECTION 7: I. the Attorney General

IN WITNESS WHEREOF, I have hereunto set my hand officially and caused to be affixed the Great Seal of the State of Louisiana, at the Capitol, in the City of Baton Rouge, Louisiana, on this 15th day of November, 1993.

Edwin Edwards
Governor

ATTEST BY
THE GOVERNOR
Fox McKeithen
Secretary of State

EXECUTIVE ORDER EWE 93-40

WHEREAS: pursuant to the Tax Reform Act of 1986 (the "Act") and Act 51 of the 1986 Louisiana Legislative Session, Executive Order No. EWE 92-47 establishes (i) a method for the allocation of bonds subject to the private activity bond volume limits, including the method of allocation of bonds subject to the private activity bond volume limits for this calendar year 1993 (the "1993 Ceiling"), (ii) the procedure for obtaining an allocation of bonds under the 1993 Ceiling and (iii) a system of central record keeping for such allocations, and

WHEREAS: the Port of Iberia District has requested an allocation from the 1993 Ceiling to be used in connection with the financing of constructing capital improvements to encourage the location of an industrial enterprise (the "Project"); and

WHEREAS: the Governor has determined that the Project serves a crucial need and provides a benefit to the State of Louisiana and the Port of Iberia District; and

WHEREAS: it is the intent of the Governor of the State of Louisiana that this executive order, to the extent inconsistent with the provisions of Executive Order No. EWE 92-47, supercedes and prevails over such provisions with respect to the allocation made herein;

NOW, THEREFORE, BE IT ORDERED BY EDWIN W. EDWARDS, Governor of the State of Louisiana, as follows:

SECTION 1: That the bond issue described in this Section is hereby granted an allocation from the 1993 Ceiling in the amount shown:

AMOUNT OF ALLOCATION \$250,000	NAME OF ISSUER Port of Iberia District	NAME OF PROJECT Certification of Indebtedness
--------------------------------------	---	--

SECTION 2: The allocation granted hereunder is to be used only for the bond issue described in Section 1 and for the general purpose set in the "Application for Allocation of a Portion of the State of Louisiana IDB Ceiling" submitted in connection with the bonds described in Section 1.

SECTION 3: The allocation granted hereby shall be valid and in full force and effect through December 1, 1993, provided that such bonds are delivered to the initial purchasers thereof on or before December 1, 1993.

SECTION 4: The undersigned certifies, under penalty of perjury, that the allocation granted hereby was not made in consideration of any bribe, gift, gratuity, or direct or indirect contribution to any political campaign.

SECTION 5: That this executive order, to the extent conflicting with the provisions of Executive Order No. EWE 92-47, supercedes and prevails over the provisions of such executive order.

SECTION 6: All references herein to the singular shall include the plural and all plural references shall include the singular.

SECTION 7: This executive order shall be effective upon signature of the Governor.

IN WITNESS WHEREOF, I have hereunto set my hand officially and caused to be affixed the Great Seal of the State of Louisiana, at the Capitol, in the City of Baton Rouge, Louisiana, on this 16th day of November, 1993.

Edwin Edwards
Governor

ATTEST BY
THE GOVERNOR
Fox McKeithen
Secretary of State

EXECUTIVE ORDER EWE 93-41

WHEREAS: pursuant to the Tax Reform Act of 1986 (the "Act") and Act 51 of the 1986 Louisiana Legislative Session, Executive Order No. EWE 92-47 establishes (i) a method for the allocation of bonds subject to the private activity bond volume limits, including the method of allocation of bonds subject to the private activity bond volume limits for this calendar year 1993 (the "1993 Ceiling"), (ii) the procedure for obtaining an allocation of bonds under the 1993 Ceiling and (iii) a system of central record keeping for such allocations, and

WHEREAS: the Industrial Development Board of the Parish of Calcasieu, Inc. has requested an allocation from the 1993 Ceiling to be used in connection with the financing of the acquisition or purchase of certain water pollution control facilities (the "Project") at the refinery facilities of CITGO Petroleum Corporation located in Calcasieu Parish, Louisiana; and

WHEREAS: the Governor has determined that the Project serves a crucial need and provides a benefit to the State of Louisiana and the Parish of Calcasieu; and

WHEREAS: it is the intent of the Governor of the State of Louisiana that this executive order, to the extent inconsistent with the provisions of Executive Order No. EWE 92-47, supercedes and prevails over such provisions with respect to the allocation made herein;

NOW, THEREFORE, BE IT ORDERED BY EDWIN W. EDWARDS, Governor of the State of Louisiana, as follows:

SECTION 1: That the bond issue described in this Section is hereby granted an allocation from the 1993 Ceiling in the amount shown:

AMOUNT OF ALLOCATION \$50,000,000	NAME OF ISSUER Industrial Development Board of the Parish of Calcasieu, Inc.	NAME OF PROJECT CITGO Petroleum Corporation
---	--	--

SECTION 2: The allocation granted hereunder is to be used only for the bond issue described in Section 1 and for the general purpose set in the "Application for Allocation of a Portion of the State of Louisiana IDB Ceiling" submitted in connection with the bonds described in Section 1.

SECTION 3: The allocation granted hereby shall be valid and in full force and effect through December 23, 1993, provided that such bonds are delivered to the initial purchasers thereof on or before December 23, 1993.

SECTION 4: The undersigned certifies, under penalty of perjury, that the allocation granted hereby was not made in consideration of any bribe, gift, gratuity, or direct or indirect contribution to any political campaign.

SECTION 5: That this executive order, to the extent conflicting with the provisions of Executive Order No. EWE 92-47, supercedes and prevails over the provisions of such executive order.

SECTION 6: All references herein to the singular shall include the plural and all plural references shall include the singular.

SECTION 7: This executive order shall be effective upon signature of the Governor.

IN WITNESS WHEREOF, I have hereunto set my hand officially and caused to be affixed the Great Seal of the State of Louisiana, at the Capitol, in the City of Baton Rouge, Louisiana, on this 3rd day of December, 1993.

Edwin Edwards
Governor

ATTEST BY
THE GOVERNOR
Fox McKeithen
Secretary of State

EXECUTIVE ORDER EWE 93-42

WHEREAS: pursuant to the Tax Reform Act of 1986 (the "Act") and Act 51 of the 1986 Louisiana Legislative Session, Executive Order No. EWE 92-47 establishes (i) a method for the allocation of bonds subject to the private activity bond volume limits, including the method of allocation of bonds subject to the private activity bond volume limits for this calendar year 1993 (the "1993 Ceiling"), (ii) the procedure for obtaining an allocation of bonds under the 1993 Ceiling and (iii) a system of central record keeping for such allocations, and

WHEREAS: the Industrial District No. 3 of the Parish of West Baton Rouge has requested an allocation from the 1993 Ceiling to be used in connection with the financing of the acquisition or purchase of certain water pollution control facilities (the "Project") at the chemical plant complex located in and adjoining West Baton Rouge Parish, Louisiana; and

WHEREAS: the Governor has determined that the Project serves a crucial need and provides a benefit to the State of Louisiana and the Parish of West Baton Rouge; and

WHEREAS: it is the intent of the Governor of the State of Louisiana that this executive order, to the extent inconsistent with the provisions of Executive Order No. EWE 92-47, supercedes and prevails over such provisions with respect to the allocation made herein;

NOW, THEREFORE, BE IT ORDERED BY EDWIN W. EDWARDS, Governor of the State of Louisiana, as follows:

SECTION 1: That the bond issue described in this Section is hereby granted an allocation from the 1993 Ceiling in the amount shown:

AMOUNT OF ALLOCATION	NAME OF ISSUER	NAME OF PROJECT
\$30,000,000	Industrial District No. 3 of the Parish of West Baton Rouge	The Dow Chemical Company

SECTION 2: The allocation granted hereunder is to be used only for the bond issue described in Section 1 and for the general purpose set in the "Application for Allocation of a Portion of the State of Louisiana IDB Ceiling" submitted in connection with the bonds described in Section 1.

SECTION 3: The allocation granted hereby shall be valid and in full force and effect through December 23, 1993, provided that such bonds are delivered to the initial purchasers thereof on or before December 23, 1993.

SECTION 4: The undersigned certifies, under penalty of perjury, that the allocation granted hereby was not made in consideration of any bribe, gift, gratuity, or direct or indirect contribution to any political campaign.

SECTION 5: That this executive order, to the extent conflicting with the provisions of Executive Order No. EWE 92-47, supercedes and prevails over the provisions of such executive order.

SECTION 6: All references herein to the singular shall include the plural and all plural references shall include the singular.

SECTION 7: This executive order shall be effective upon signature of the governor.

IN WITNESS WHEREOF, I have hereunto set my hand officially and caused to be affixed the Great Seal of the State

of Louisiana, at the Capitol, in the City of Baton Rouge, Louisiana, on this 3rd day of December 1993.

Edwin Edwards
Governor

ATTEST BY
THE GOVERNOR
Fox McKeithen
Secretary of State

EXECUTIVE ORDER EWE 93-43

WHEREAS: pursuant to the Tax Reform Act of 1986 (the "Act") and Act 51 of the 1986 Louisiana Legislative Session, Executive Order No. EWE 92-47 establishes (i) a method for the allocation of bonds subject to the private activity bond volume limits, including the method of allocation of bonds subject to the private activity bond volume limits for this calendar year 1993 (the "1993 Ceiling"), (ii) the procedure for obtaining an allocation of bonds under the 1993 Ceiling and (iii) a system of central record keeping for such allocations, and

WHEREAS: the Parish of Natchitoches has requested an allocation from the 1993 Ceiling to be used in connection with the financing of the acquisition or purchase of certain solid waste disposal facilities (the "Project") at the paper mill (Red River Mill) of Willamette Industries, Inc. located in Campti, within the Parish of Natchitoches, Louisiana; and

WHEREAS: the governor has determined that the Project serves a crucial need and provides a benefit to the State of Louisiana and the Parish of Natchitoches; and

WHEREAS: it is the intent of the Governor of the State of Louisiana that this executive order, to the extent inconsistent with the provisions of Executive Order No. EWE 92-47, supercedes and prevails over such provisions with respect to the allocation made herein;

NOW, THEREFORE, BE IT ORDERED BY EDWIN W. EDWARDS, Governor of the State of Louisiana, as follows:

SECTION 1: That the bond issue described in this Section is hereby granted an allocation from the 1993 Ceiling in the amount shown:

AMOUNT OF ALLOCATION	NAME OF ISSUER	NAME OF PROJECT
\$18,000,000	Parish of Natchitoches	Willamette Industries, Inc.

SECTION 2: The allocation granted hereunder is to be used only for the bond issue described in Section 1 and for the general purpose set in the "Application for Allocation of a Portion of the State of Louisiana IDB Ceiling" submitted in connection with the bonds described in Section 1.

SECTION 3: The allocation granted hereby shall be valid and in full force and effect through December 23, 1993, provided that such bonds are delivered to the initial purchasers thereof on or before December 23, 1993.

SECTION 4: The undersigned certifies, under penalty of perjury, that the allocation granted hereby was not made in consideration of any bribe, gift, gratuity, or direct or indirect contribution to any political campaign.

SECTION 5: That this executive order, to the extent conflicting with the provisions of Executive Order No. EWE 92-47, supercedes and prevails over the provisions of such executive order.

SECTION 6: All references herein to the singular shall include the plural and all plural references shall include the singular.

SECTION 7: This executive order shall be effective upon signature of the Governor.

IN WITNESS WHEREOF, I have hereunto set my hand officially and caused to be affixed the Great Seal of the State of Louisiana, at the Capitol, in the City of Baton Rouge, Louisiana, on this 3rd day of December 1993.

Edwin Edwards
Governor

ATTEST BY
THE GOVERNOR
Fox McKeithen
Secretary of State

EXECUTIVE ORDER EWE 93-44

WHEREAS: pursuant to the Tax Reform Act of 1986 (the "Act") and Act 51 of the 1986 Louisiana Legislative Session, Executive Order No. EWE 92-47 establishes (i) a method for the allocation of bonds subject to the private activity bond volume limits, including the method of allocation of bonds subject to the private activity bond volume limits for this calendar year 1993 (the "1993 Ceiling"), (ii) the procedure for obtaining an allocation of bonds under the 1993 Ceiling and (iii) a system of central record keeping for such allocations, and

WHEREAS: the Parish of St. Charles has requested an allocation from the 1993 Ceiling to be used in connection with the financing of the acquisition or purchase of certain solid waste disposal facilities and water pollution control facilities (the "Project") at Unit 3 (nuclear) of the Waterford Steam Electric Station of Louisiana Power & Light Company located in St. Charles Parish, Louisiana; and

WHEREAS: the governor has determined that the Project serves a crucial need and provides a benefit to the State of Louisiana and the Parish of St. Charles; and

WHEREAS: it is the intent of the Governor of the State of Louisiana that this executive order, to the extent inconsistent with the provisions of Executive Order No. EWE 92-47, supercedes and prevails over such provisions with respect to the allocation made herein;

NOW, THEREFORE, BE IT ORDERED BY EDWIN W. EDWARDS, Governor of the State of Louisiana, as follows:

SECTION 1: That the bond issue described in this Section is hereby granted an allocation from the 1993 Ceiling in the amount shown:

AMOUNT OF ALLOCATION	NAME OF ISSUER	NAME OF PROJECT
\$25,000,000	Parish of St. Charles	Louisiana Power & Light Company

SECTION 2: The allocation granted hereunder is to be used only for the bond issue described in Section 1 and for the general purpose set in the "Application for Allocation of a Portion of the State of Louisiana IDB Ceiling" submitted in connection with the bonds described in Section 1.

SECTION 3: The allocation granted hereby shall be valid and in full force and effect through December 23, 1993, provided that such bonds are delivered to the initial purchasers thereof on or before December 23, 1993.

SECTION 4: The undersigned certifies, under penalty of perjury, that the allocation granted hereby was not made in consideration of any bribe, gift, gratuity, or direct or indirect contribution to any political campaign.

SECTION 5: That this executive order, to the extent conflicting with the provisions of Executive Order No. EWE 92-47, supercedes and prevails over the provisions of such executive order.

SECTION 6: All references herein to the singular shall include the plural and all plural references shall include the singular.

SECTION 7: This executive order shall be effective upon signature of the Governor.

IN WITNESS WHEREOF, I have hereunto set my hand officially and caused to be affixed the Great Seal of the State of Louisiana, at the Capitol, in the City of Baton Rouge, Louisiana, on this 3rd day of December 1993.

Edwin Edwards
Governor

ATTEST BY
THE GOVERNOR
Fox McKeithen
Secretary of State

EXECUTIVE ORDER EWE 93-45

WHEREAS: pursuant to the Tax Reform Act of 1986 (the "Act") and Act 51 of the 1986 Louisiana Legislative Session, Executive Order No. EWE 92-47 establishes (i) a method for the allocation of bonds subject to the private activity bond volume limits, including the method of allocation of bonds subject to the private activity bond volume limits for this calendar year 1993 (the "1993 Ceiling"), (ii) the procedure for obtaining an allocation of bonds under the 1993 Ceiling and (iii) a system of central record keeping for such allocations, and

WHEREAS: the Louisiana Housing Finance Agency has requested an allocation from the 1993 Ceiling to be used in connection with the financing of the acquisition, rehabilitation and equipping of a multifamily residential rental project substantially for persons of low and moderate income (the "Project") in Baton Rouge, East Baton Rouge Parish, Louisiana; and

WHEREAS: the governor has determined that the Project serves a crucial need and provides a benefit to the State of Louisiana and the Parish of East Baton Rouge; and

EMERGENCY RULES

DECLARATION OF EMERGENCY

Department of Economic Development Racing Commission

Equipment for Jockeys (LAC 35:IX.9503)

The State Racing Commission is exercising the emergency provisions of the Administrative Procedure Act, R.S. 49:953 (B), and pursuant to the authority granted under R.S. 4:141 et seq., adopts the following emergency rule effective January 1, 1994, and it shall remain in effect for 120 days or until this rule takes effect through the normal promulgation process, whichever comes first.

The State Racing Commission finds it necessary to amend this rule to include jockey vests as a method of protecting the life and health of jockeys in racing.

Title 35

HORSE RACING

Part IX. Weights

Chapter 95. Weighing Out

§9503. Equipment

A. If a horse runs in a throttle, hood, muzzle, martingale, breast plate or suspensory, they must be included in the jockey's weight. His weight shall also include his clothing, boots, goggles, arm number, saddle and its attachments, saddle cloth, pommel pad, etc. No whip, bridle, blinkers, head number, bit, reins safety vest, safety helmet or number cloth shall be weighed. No safety vest or bridle shall exceed two pounds each in weight, and no whip shall exceed one pound in weight.

B. No jockey or apprentice jockey shall participate in any race conducted by any association unless he or she wears a safety vest, designed to provide shock absorbing protection to the upper body, as evidenced by a label with at least a rating of five, by the British Equestrian Trade Association. The clerk of scales shall be responsible for insuring compliance with this rule.

AUTHORITY NOTE: Promulgated in accordance with R.S. 4:141, R.S. 4:142 and R.S. 4:148.

HISTORICAL NOTE: Adopted by the State Racing Commission, in 1971, amended by the Department of Commerce, Racing Commission, LR 2:444 (December 1976), repromulgated LR 3:40 (January 1977), LR 4:284 (August 1978), amended by the Department of Economic Development, Racing Commission, LR 20:

Paul D. Burgess
Executive Director

WHEREAS: it is the intent of the Governor of the State of Louisiana that this executive order, to the extent inconsistent with the provisions of Executive Order No. EWE 92-47, supercedes and prevails over such provisions with respect to the allocation made herein;

NOW, THEREFORE, BE IT ORDERED BY EDWIN W. EDWARDS, Governor of the State of Louisiana, as follows:

SECTION 1: That the bond issue described in this Section is hereby granted an allocation from the 1993 Ceiling in the amount shown:

AMOUNT OF ALLOCATION	NAME OF ISSUER	NAME OF PROJECT
\$7,750,000	Louisiana Housing Finance Agency	Tall Timbers Apartments

SECTION 2: The allocation granted hereunder is to be used only for the bond issue described in Section 1 and for the general purpose set in the "Application for Allocation of a Portion of the State of Louisiana IDB Ceiling" submitted in connection with the bonds described in Section 1.

SECTION 3: The allocation granted hereby shall be valid and in full force and effect through December 23, 1993, provided that such bonds are delivered to the initial purchasers thereof on or before December 23, 1993.

SECTION 4: The undersigned certifies, under penalty of perjury, that the allocation granted hereby was not made in consideration of any bribe, gift, gratuity, or direct or indirect contribution to any political campaign.

SECTION 5: That this executive order, to the extent conflicting with the provisions of Executive Order No. EWE 92-47, supercedes and prevails over the provisions of such executive order.

SECTION 6: All references herein to the singular shall include the plural and all plural references shall include the singular.

SECTION 7: This executive order shall be effective upon signature of the Governor.

IN WITNESS WHEREOF, I have hereunto set my hand officially and caused to be affixed the Great Seal of the State of Louisiana, at the Capitol, in the City of Baton Rouge, Louisiana, on this 3rd day of December 1993.

Edwin Edwards
Governor

ATTEST BY
THE GOVERNOR
Fox McKeithen
Secretary of State

DECLARATION OF EMERGENCY

Department of Economic Development Racing Commission

No Medication in 2-Year-Olds (LAC 35:I.1722)

The State Racing Commission is exercising the emergency provisions of the Administrative Procedure Act, R.S. 49:953 (B), and pursuant to the authority granted under R.S. 4:141 et seq., adopts the following emergency rule effective Saturday, January 1, 1994, and it shall remain in effect for 120 days or until this rule takes effect through the normal promulgation process, whichever comes first.

The State Racing Commission finds it necessary to repeal this rule since 2-year-old horses will now be treated as all other horses, making the rule obsolete.

Title 35

HORSE RACING

Part I. General Provisions

Chapter 17. Corrupt and Prohibited Practices

§1722. No Medication in 2-Year-Olds

Repealed in its entirety.

AUTHORITY NOTE: Promulgated in accordance with R.S. 4:148.

HISTORICAL NOTE: Promulgated by the Department of Commerce, Racing Commission, LR 12:11 (January 1986), amended by the Department of Economic Development, Racing Commission, LR 19:612 (May 1993), repealed LR 20:

Paul D. Burgess
Executive Director

DECLARATION OF EMERGENCY

Department of Economic Development Racing Commission

Permitted Medication for 2-Year-Olds (LAC 35:I.1503)

The State Racing Commission is exercising the emergency provisions of the Administrative Procedure Act, R.S. 49:953 (B), and pursuant to the authority granted under R.S. 4:141 et seq., adopts the following emergency rule effective Saturday, January 1, 1994, and it shall remain in effect for 120 days or until this rule takes effect through the normal promulgation process, whichever comes first.

The State Racing Commission finds it necessary to repeal this rule since 2-year-old horses will now be treated as all other horses, making the rule obsolete.

Title 35

HORSE RACING

Part I. General Provisions

Chapter 15. Permitted Medication

§1503. Two-Year Olds

Repealed in its entirety.

AUTHORITY NOTE: Promulgated in accordance with R.S. 4:141 and 142.

HISTORICAL NOTE: Promulgated by the Department of Commerce Racing Commission, LR 2:451 (December 1976), repromulgated LR 4:289 (August 1978), amended LR 6:620 (December 1981), LR 9:547 (August 1983), repealed by the Department of Economic Development, Racing Commission LR 20:

Paul D. Burgess
Executive Director

DECLARATION OF EMERGENCY

Board of Elementary and Secondary Education

Teacher Tuition Exemption FY 1993-94

The State Board of Elementary and Secondary Education has exercised those powers conferred by the Administrative Procedure Act R.S. 49:953(B) and readopted as an emergency rule, the revised Teacher Tuition Exemption Regulations for FY 1993-1994. These regulations were previously adopted as an emergency rule and printed in full in the September, 1993 issue of the *Louisiana Register* on pages 1094 thru 1096. Readoption of the regulations as an emergency rule is necessary in order to continue the present rule until it is finalized as a rule. Effective date of this emergency rule is December 27, 1993 and it shall remain in effect for 120 days or until the final rule is adopted, whichever occurs first.

Carole Wallin
Executive Director

DECLARATION OF EMERGENCY

Department of Environmental Quality Office of the Secretary

Importation of Foreign Hazardous Waste (LAC 33:V.1101, 1113)(HW38E)

In accordance with the emergency provisions of the Administrative Procedure Act, R.S. 49:953(B), and under the authority of R.S. 30:2011, the secretary of the Department of Environmental Quality declares that an emergency action is necessary because Louisiana's laws prohibiting the importation of hazardous waste from foreign countries have been declared unconstitutional. It is necessary for the department to adopt this emergency rule to require such waste to comply with the hazardous waste regulations that govern the treatment, storage and disposal of hazardous waste in Louisiana. The following emergency rule is hereby adopted to carry out the intent of the legislature which is to ensure that the environment and the health of the citizens of this state are not endangered by the importation of hazardous wastes generated in foreign

countries. The immediate effect of the rule is twofold: 1) to ensure that hazardous waste being imported to the United States does not contain unknown or unauthorized pollutants that could be released to the environment because of inadequate containment, labeling, or handling during transport; and 2) to apprise the citizens in the area of the receiving facility, through public notice, of impending arrival of hazardous waste from a foreign country.

This emergency rule is effective on December 3, 1993, and shall remain in effect for the maximum of 120 days or until a final rule is promulgated, whichever occurs first.

Title 33

ENVIRONMENTAL QUALITY

Part V. Hazardous Waste and Hazardous Materials

Subpart 1. Department of Environmental Quality—Hazardous Waste

Chapter 11. Generators

§1101. Applicability

A. A generator who treats, stores, or disposes of hazardous waste on-site is not required to comply with the requirements of this Chapter except for the following with respect to that waste: LAC 33:V.1101.C, 1103, 1105, 1109.E, 1111.A.3, 1111.A.4, 1111.D, 1115, 1117, 1119, and 1121.

B. Any person who imports hazardous waste into Louisiana must comply with the standards applicable to generators established in this Chapter. Any person who imports hazardous waste from a foreign country into Louisiana must ensure that the generator in the foreign country is identified and will properly characterize and ship the waste pursuant to the LHWR and LDPS regulations. If the importer detects any discrepancy with, or violation of, the applicable regulations, his/her recourse will be to reject the hazardous waste shipment and notify the administrative authority and the generator within 24 hours of the determination of such discrepancy and/or violation of the LHWR.

* * *

AUTHORITY NOTE: Promulgated in accordance with R.S. 30:2180 et seq.

HISTORICAL NOTE: Promulgated by the Department of Environmental Quality, Office of Solid and Hazardous Waste, Hazardous Waste Division, LR 10:200 (March 1984), amended LR 16:398-399 (May 1990), LR 20:

§1113. International Exports, Imports of Hazardous Waste

A. **Applicability.** Any person who exports/imports hazardous waste to/from a foreign country, from a point of departure or to a point of arrival in Louisiana, must comply with the requirements of this Chapter. This Section establishes requirements applicable to international exports and imports of hazardous waste. A transporter transporting hazardous waste for export or import must comply with applicable requirements of LAC 33:V.Chapter 13.

B. **Definitions.** The following terms are used in these regulations as defined (in alphabetical order) in LAC 33:V.109: consignee, Louisiana State Acknowledgement of Consent, primary exporter, receiving country, and transit country.

C. **General Requirements.** International exports and imports of hazardous waste must comply with the applicable

requirements of LAC 33:V.Chapters 11 and 13. Persons who import or export hazardous waste must demonstrate that:

1. notification in accordance with LAC 33:V.1113.D has been provided;
2. the appropriate authority in the receiving foreign country has consented to accept the hazardous waste;
3. consent to the shipment and notice to the department accompanies and is attached to the manifest (or shipping paper for exports and imports by water [bulk shipment]); and
4. the hazardous waste shipment conforms to the terms of the manifest and, if applicable, to the terms of the receiving country's written consent.

D. Notification of Intent to Export or Import Hazardous Waste

1. A primary exporter or importer of hazardous waste must notify the administrative authority of an intended export or import before such waste is scheduled to leave or enter the United States. A complete notification must be submitted to the department 60 days before the initial shipment is intended to be shipped off-site. If the country from which the waste is shipped requires more than 60-days notice for the import of hazardous waste, then the greater time period for notice to the administrative authority will apply to the export/import of waste to/from Louisiana. This notification may cover export or import activities extending over a 12-month or lesser period. The notification must be in writing, signed by the primary exporter or importer, and include the following information:

- a. name, mailing address, telephone number, and EPA ID number of the primary exporter or importer;
- b. for each hazardous waste type:
 - i. a description of the hazardous waste and the EPA hazardous waste number (from 40 CFR Part 261, Subparts C and D, pp. 404-422, 1988), Louisiana Department of Public Safety and Corrections (or its successor agency) proper shipping name, hazard class, and ID number for each hazardous waste;
 - ii. the estimated frequency or rate at which such waste is to be exported and imported and the period of time over which such waste is to be exported and imported;
 - iii. the estimated total quantity of the hazardous waste in units as specified in the instructions to the Uniform Hazardous Waste Manifest Form (8700-22);
 - iv. all points of entry to and departure from each foreign country through which the hazardous waste will pass;
 - v. a description of the means by which each shipment of the hazardous waste will be transported (e.g., mode of transportation vehicle [air, highway, rail, water, etc.], type[s] of container [drums, boxes, tanks, etc.]);
 - vi. a description of the manner in which the hazardous waste will be treated, stored, or disposed of in the receiving country (e.g., land or ocean incineration, other land disposal, ocean dumping, recycling);
 - vii. the name and site address of the consignee and any alternate consignee; and
 - viii. the name of any transit countries through which the hazardous waste will be sent and a description of the approximate length of time the hazardous waste will remain in such country and the nature of its handling while there.

DECLARATION OF EMERGENCY

Department of Health and Hospitals Office of Management and Finance

2. Notification shall be sent to the administrative authority of the Louisiana Department of Environmental Quality with "Attention: Notification to Export/Import" prominently displayed on the front of the envelope. Such notice shall be sent by certified mail.

3. Except for changes to the telephone number or decreases in the quantity indicated pursuant to Subsection D.1.b.iii of this Section, any changes to the original notification (including any exceedance of the estimate of the quantity of hazardous waste specified in the original notification), must be provided to the administrative authority with a written re-notification of the change. The shipment cannot take place until consent to the changes is obtained from the exporting country, or the Louisiana administrative authority in case of imports (except for changes to Subsection D.1.b.iv and viii of this Section).

4. Upon request by the administrative authority, a primary exporter or importer shall furnish to the administrative authority any additional information to complete a notification.

5. The administrative authority will provide copies of complete notifications to the receiving country and any transit countries. A notification is deemed complete by the administrative authority when it satisfies the requirements of this Subsection. Where a claim of confidentiality is asserted with respect to the notification information required, the administrative authority may find the notification not complete until any such claim is resolved in accordance with LAC 33:V.317.C and LAC 33:V.319.

6. When the foreign country consents to the receipt of the hazardous waste, the administrative authority will forward an acknowledgement of consent to the primary exporter for purposes of LAC 33:V.1113.E.8. Where the receiving country objects to receipt of the hazardous waste or withdraws a prior consent, the administrative authority will notify the primary exporter in writing. The administrative authority will also notify the primary exporter of any responses from transit countries.

7. Any Louisiana facility receiving hazardous waste generated in a foreign country must publish a notice of intent to receive hazardous waste in a major newspaper of general circulation in the area where the facility is located. Such notice shall be a minimum of 3" x 3" in size and will contain the following information: name and address of the receiving facility, name of the country of origin of the hazardous waste, a brief description of the waste, the amount to be shipped, and the scheduled date of arrival. Publication must be made at the time notice of intent is submitted to the department and proof thereof shall be submitted to the administrative authority within 10 days of publication date.

* * *

AUTHORITY NOTE: Promulgated in accordance with R.S. 30:2180 et seq.

HISTORICAL NOTE: Promulgated by the Department of Environmental Quality, Office of Solid and Hazardous Waste, Hazardous Waste Division, LR 10:200 (March 1984), amended LR 16:220 (March 1990), amended by the Department of Environmental Quality, Office of the Secretary, LR 20:

Kai David Midboe
Secretary

Reimbursement for Inpatient Hospital Services in Rural Hospitals

The Department of Health and Hospitals, Office of the Secretary has adopted the following rule as authorized by R.S. 46:153 and pursuant to Title XIX of the Social Security Act. This emergency rule is in accordance with the provisions of the Administrative Procedure Act, R.S. 49:953 (B).

The department has utilized emergency rulemaking to change the reimbursement methodology for rural hospitals with 60 beds or less which have a service municipality with a population of 20,000 or less. These rural hospitals are not subject to the cost per discharge limitations. Effective for admissions November 1, 1990, rural hospitals which meet this criterion will be reimbursed for inpatient hospital services based on allowable costs as defined by medicare principles of reimbursement. The department initially adopted an emergency rule on this matter which was published in the October 20, 1990 issue of the *Louisiana Register*, Volume 16, page 842. The purpose of this declaration is to continue this rule in force for a period of 120 days.

The department's intent in making this change in reimbursement methodology for rural hospitals is to enhance and assure access to medical care for eligible Medicaid beneficiaries in rural areas of the state in order to comply with federal regulations, and to avoid penalties or sanctions. In addition, this change not only provides additional reimbursement for these facilities by permitting reasonable and necessary increases in cost associated with medical manpower, shortage areas and higher transportation expenses for supplies and equipment; but also it is expected to result in an overall cost savings as patients will be provided services in these rural hospitals when appropriate services are available rather than being transferred to large urban hospitals where the operational costs are higher due to the tertiary levels of care available.

EMERGENCY RULE

The reimbursement for inpatient hospital services to rural hospitals (as defined by medicare) with 60 beds or less which has a service municipality with a population of 20,000 or less shall be based on allowable costs as defined by medicare principles of reimbursement. Cost per discharge limitations shall not be applied to these facilities.

Disapproval of this action by the Health Care Financing Administration will automatically cancel the provisions of this emergency rule and former policy will be reinstated.

Interested persons may submit written comments to the following address: Thomas D. Collins, Office of the Secretary, Bureau of Health Services Financing, Box 91030, Baton Rouge, LA. He is responsible for responding to inquiries regarding this emergency rule and providing information about a public hearing on this matter. Copies of this rule and all other Medicaid rules and regulations are

available at parish Medicaid offices for review by interested parties.

Rose V. Forrest
Secretary

DECLARATION OF EMERGENCY

Department of Health and Hospitals Office of the Secretary

Annual Service Agreement

The Department of Health and Hospitals, Office of the Secretary, is adopting the following emergency rule in accordance with the Administrative Procedure Act, R.S. 49:953(B), and under the authority of R.S. 46:701 et seq., as amended and reenacted by Act 390 of 1991. This emergency rule will remain in effect for 120 days.

Annual Service Agreement

Introduction

This service agreement for State Fiscal Year 1993-94 is entered into by the Department of Health and Hospitals (DHH) and the Louisiana Health Care Authority (LHCA) in compliance with R.S. 46:701 et seq. as amended and reenacted by Act 390 of 1991.

I. Definitions

Licensed Beds—the number of beds in each medical center licensed by the Bureau of Health Services Financing and certified for participation in the Medicaid and Medicare programs.

Medically Indigent—any bona fide resident of the state of Louisiana whose family unit size and gross income is less than or equal to 200 percent of the Federal Poverty Income Guidelines for that size family unit, rounded up to the nearest thousand dollars.

Overcollections—any monies from Medicare, Medicaid or other third party payor, or from direct patient payments, collected by or on behalf of the medical centers operated by the LHCA in excess of the amounts budgeted in the General Appropriations bill for FY 1993-94, as enacted, for operating expenses, as certified by the commissioner of administration and the Joint Legislative Committee on the Budget.

II. General Agreement

The Louisiana Health Care Authority acknowledges that the Department of Health and Hospitals is legally responsible for the development and provision of health care services for the uninsured and medically indigent citizens of Louisiana, as well as preventative health services for the entire population.

The LHCA agrees to provide inpatient and outpatient hospital services on behalf of the Department of Health and Hospitals. The LHCA acknowledges that the provision of services to the medically indigent, to the uninsured and to others with problems of access to health care is its highest priority.

DHH agrees to work cooperatively with the authority to provide acute mental health services at authority facilities, in accordance with a Memorandum of Understanding between DHH and the LHCA.

III. Provision of Adequate Health Care Services

In accordance with the intent of Act 390 of 1991, the Louisiana Health Care Authority will strive to provide health services of sufficient quality and volume to meet the needs of the uninsured and medically indigent citizens of Louisiana. The LHCA and DHH agree that for FY 1993-94, adequate services shall be considered to consist of the following:

A. Those major services that are available at the medical centers on June 30, 1993 to any bona fide resident and taxpayer of the state of Louisiana determined to be uninsured, underinsured, or medically indigent and that are funded in the General Appropriation bill for FY 1993-94, provided that such appropriated funds are made available to the medical centers.

B. Adequate service provision shall also require that the medical centers maintain policies of access to services governed by the following:

1. The medically indigent or uninsured shall be afforded first priority for admission for any form of treatment available at the particular medical center.

2. Those persons who are determined not to be medically indigent or uninsured shall be admitted on a space available basis and shall be reasonably charged for treatment or service received.

3. Emergency treatment shall not be denied to anyone.

IV. Reduction, Elimination or Relocation of Services

A. The LHCA shall secure written approval from the secretary of DHH at least 60 days in advance of any reduction, elimination or relocation to another medical center of any major programs or services, or establishment of Centers of Excellence that require shifting of major services provided on the date of this agreement. DHH will not arbitrarily withhold approval as long as appropriate services continue to be provided and the change does not adversely effect any of the DHH's budget units.

B. The LHCA agrees not to construct, operate or fund a health care facility, or substantial portion thereof, which primarily treats insured patients other than those covered by Medicare and Medicaid.

V. Service Improvement and Development

The LHCA recognizes the need to improve and expand services in the medical centers in order to more fully meet the health care needs of the uninsured and medically indigent citizens of Louisiana. The authority will work to improve access to care, placing highest priority on the following:

A. improved access to prenatal and HIV clinics in every medical center;

B. reduced waiting times for all outpatient services for which there exist medically inappropriate delays in scheduling appointments;

C. improved access to emergency services.

D. LHCA shall not develop new programs or major program expansions in the areas of public health, substance abuse, mental health, or mental retardation without the concurrence of DHH.

E. In accordance with recognized primary care needs, as

identified by state and federal criteria, the DHH Primary Care Access Plan, the State Rural Health Care Plan, the LHCA Strategic Plan and other mutually agreed upon priorities, LHCA may implement new primary health clinics only after a systematic determination that the new services are needed by the population to be served and after thorough coordination with DHH.

This shall be accomplished by a joint DHH/LHCA planning task force. No new primary care clinics shall be presented to the LHCA board for approval until such implementation has received the prior written approval of the secretary of DHH and the CEO of the LHCA.

F. The LHCA Medical Centers will provide HIV testing and treatment services consistent with Act 634 of 1991, the DHH Services Plan and with funding provided through a separate HIV agreement with DHH. The DHH HIV Program Office in the OS/Bureau of Policy and Program Development will provide the LHCA with planning, technical assistance and monitoring of AIDS testing and treatment services and ambulatory care sites, as specified in the HIV Agreement between the two agencies. LHCA shall coordinate the development of new or expanded HIV outpatient programs with DHH.

VI. Financing Arrangements

A. DHH agrees not to adjust interim Medicaid payment rates, target rates, disproportionate share formulas, or to amend the Medicaid State Plan as it relates to inpatient and outpatient hospital services, without timely notice to the LHCA CEO.

B. LHCA agrees not to submit any Budget Adjustment (BA-7) request to DOA which increase the expenditure authority of its facilities without prior notice to the secretary of DHH.

C. DHH agrees not to submit any BA-7s to DOA where the means of financing would reflect use of unbudgeted overcollections from the LHCA without prior notice to the LHCA chief executive officer.

D. DHH and LHCA agree that prior to the March meeting of the Joint Legislative Committee on the Budget a meeting will be held to determine the amount of overcollections, if any, to be transferred from the Louisiana Health Care Authority to the Department of Health and Hospitals, as required by law.

E. LHCA agrees to provide DHH with monthly reports detailing collections by source of payment for each of its medical centers.

F. With regard to the liability for payment for services by those inpatients who are classified as self-pay, the LHCA agrees to adhere to DHH Policy No. 4600-77 (DHH Liability Limitation Policy), until such time as a revised policy may be promulgated by the authority through the Administrative Procedure Act.

G. Costs associated with the transition from DHH to LHCA administration of the medical centers and not otherwise specified in this agreement will be paid by the agency that is budgeted funds to cover those costs. Where a cost may be incurred in an area in which there is an incomplete functional separation between DHH and LHCA, each agency will bear its proportionate share of costs, based upon the approved cost

allocation plan for the particular unit or upon another appropriate methodology for determining proportionate cost, as agreed by the two agencies.

H. LHCA shall not shift monies specifically earmarked in the budget process to alternative uses without prior written approval from the secretary of the Department of Health and Hospitals.

This includes outpatient clinic services, HIV outpatient services, and nurse stipends.

I. LHCA is to provide a 90-day notice if they intend to cancel any operational service agreement with DHH facilities that could adversely affect the DHH facilities budget (i.e., laundry agreements).

VII. Annual Revision of Service Agreement

DHH and the LHCA agree to revise this service agreement on annual basis, as required by law, and to promulgate the agreement through the Administrative Procedure Act. The draft annual agreement shall be published in the *Louisiana Register* each year, in order for significant changes to be considered in the budget process for the ensuing fiscal year.

Interested persons may submit written comments to the following address: Charles F. Castille, General Counsel, Department of Health and Hospitals, Box 3836, Baton Rouge, LA, 70821. He is responsible for responding to inquires regarding this emergency rule.

Rose V. Forrest
Secretary
Department of
Health and Hospitals

William B. Cherry, M.D.
Chief Executive Officer
Louisiana Health Care Authority

DECLARATION OF EMERGENCY

Department of Health and Hospitals
Office of the Secretary
Bureau of Health Services Financing

Disproportionate Share Payment—Indigent Pool

The Department of Health and Hospitals, Office of the Secretary, Bureau of Health Services Financing, has exercised the emergency provision of the Administrative Procedure Act, R.S. 49:953(B) to readopt the following rule in the Medicaid Program to establish an indigent pool for disproportionate share hospital reimbursement as authorized by R.S. 46:153 and pursuant to Title XIX of the Social Security Act. An emergency rule was adopted on January 1, 1993 and published in the January 20, 1993 issue of the *Louisiana Register* Volume 19, Number 1 on disproportionate share payments based on a pool of indigent days. This emergency rule was redeclared effective May 1, 1993 and August 29, 1993 and published in the May 20, 1993 and September 20, 1993 issues of the *Louisiana Register* to ensure the continuation of the

following provisions for disproportionate share payments pending approval by the Health Care Financing Administration. In addition a notice of intent on this issue was published in the April 20, 1993 issue of the *Louisiana Register* Volume 19, Number 4. This emergency rule will remain in effect for 120 days or until final adoption of the rule.

Medicaid currently reimburses for inpatient care in either a free-standing psychiatric hospital or an acute care general hospital with a methodology which includes an adjustment for hospitals serving a disproportionate share of low-income patients as well as an additional disproportionate share adjustment which utilizes different qualifying criteria and payment adjustment methodology. Previously there has been no limit on the amounts of disproportionate share adjustment payments, but as a result of Public Law 102-234, a national and statewide cap has been placed on disproportionate share adjustment payments beginning October 1, 1992. Louisiana is already over the base state allotment for disproportionate share payments of 12 percent of its total Medicaid expenditures projected for federal fiscal year (FFY) 1993, and is therefor capped at the amount of disproportionate share expenditures in FFY 1992. In federal regulations promulgated November 24, 1992 (FR Vol. 57, No. 227, pages 55118-55265), the national cap of 12 percent is projected to also be exceeded, resulting in reductions to each state's allotment proportional to the percentage of each state's DSH base allotment to the total of all state DSH base allotments multiplied by the amount that all state DSH base allotments exceed the aggregate national 12 percent DSH spending limit. As Louisiana is a high DSH state and already projects disproportionate share payments in FFY 93 in excess of its allotment, a change in the methodology for determining disproportionate share adjustment payments is being implemented to ensure that DSH expenditures remain within the cap imposed by P. L. 102-234 and the HCFA regulations promulgated to implement this law. This action is necessary to reduce the projected DSH payments to a level that will remain under the cap. This emergency rule will ensure that other services for health care to the needy of the state would remain available as otherwise reductions in these services may result if the cap is exceeded and the state must bear the full burden of DSH payments in excess of the cap.

EMERGENCY RULE

Effective for dates of service December 27, 1993, the Department of Health and Hospitals, Bureau of Health Services Financing amends the methodology for calculating the amount of disproportionate share payments for inpatient hospital services to provide for an additional disproportionate share payment for hospitals which utilizes payment based on the number of indigent care inpatient days (exclusive of Medicaid inpatient days) in a pool of all such days for all qualifying disproportionate share hospitals. Indigent days shall not be annualized for purposes of the pool. A lump sum payment will be made annually to each disproportionate share hospital equal to the product of the ratio of each hospital's total indigent care days in the prior state fiscal year, divided by the total indigent inpatient days in the same period by all disproportionate share hospitals, multiplied by an amount of funds to be determined by the director of the Bureau of Health

Services Financing, but not to exceed in the aggregate with all other disproportionate share payments the total cap on disproportionate share expenditures established under P.L. 102-234.

This additional disproportionate share payment is payable to all qualifying disproportionate share hospitals with indigent care days in the specified period (acute care general, free-standing psychiatric hospitals, and distinct part psychiatric units) and in addition to other disproportionate share payments. All hospital indigent care (free care) plans must be submitted to and approved by the director of Institutional Reimbursement of the Bureau of Health Services Financing and must meet the criteria delineated below:

1. The annual family income for patients qualifying for free care may not exceed 200 percent of the Federal Poverty Income Guidelines.

2. The facility must advise the public of the availability of free care services and of its policies for qualifying patients for free care. The facility must post a written copy of its policy conspicuously in all patient treatment areas, admissions and the business office and provide individual written notices to patients and/or their family members upon admission.

3. The facility must provide a form for individuals to apply for free care services upon admission to the facility. These forms must be maintained on file and be available for audit in accordance with all federal rules and regulations. The application must be signed by the applicant except for patients deemed mentally unstable by the physician and for which access for interview has been restricted by physician's orders. The facility must supply auditors with facility's procedures for verification of available payment sources for such patients.

4. The facility must make a determination of the patient's eligibility for free care services within two working days after application, notify the patient properly of decision, and keep a copy on file for audit in accordance with federal rules and regulations. Income verification should be attempted via review of pay stubs, W-2 records, unemployment compensation book, or collateral contact with employer, etc. If income verification has not been completed within two working days, the facility may condition the determination of eligibility on income verification. The conditional determination must be completed within two working days of the request for free care.

5. The facility must maintain a log of free care services provided each fiscal year for audit purposes in compliance with federal rules and regulations. Patient identifying information such as patient name, social security number, date of birth, dates of service, medical record number, patient account number, number of free care days, and amount of free care charges must be included on the log.

6. Indigent days may only be included as days in the indigent pool to the extent that the entire day is deemed free care. If free care is determined on a sliding scale which is based on total charges, any day for which the patient is liable for more than 50 percent of the charges may *not* be considered as free care. Inpatient days denied for Medicaid recipients who had exhausted their Medicaid inpatient days may be recognized as indigent days provided that documentation of the reasons for denial demonstrates that the recipient is over the

limit of days. Medicaid days denied for other reasons resulting from failure to comply with Medicaid policies and procedures will not be recognized as indigent days. Prisoners receiving services in state hospitals are deemed indigent in accordance with state law. Inpatient days paid by Medicaid are *not* recognized as indigent days. Nor are Hill-Burton days that are utilized to meet an obligation under this program recognized as free care days. Medicare bad debt days are not allowable as indigent days. Days for accounts written off as bad debt are not allowable as indigent days.

7. For state-operated facilities, a free care plan promulgated and implemented in accordance with state law and regulations shall be recognized for determining indigent days included in the indigent pool for additional disproportionate share payments.

Disapproval of this change by the Health Care Financing Administration will automatically cancel the provisions of this rule and current policy will remain in effect.

Rose V. Forrest
Secretary

DECLARATION OF EMERGENCY

Department of Health and Hospitals
Office of the Secretary
Bureau of Protective Services

Referral and Investigation Procedures
(LAC 48:I.17101-17125)

In accordance with the emergency provision of the Administrative Procedure Act, R.S. 49:953(B) and under the authority of R.S. 14:403.2, the secretary of the Department of Health and Hospitals (DHH) has determined that to avoid imminent peril to the public health, safety and welfare, emergency adoption of the following rule is necessary to enable the department to implement the Protective Services Agency for individuals 18-59 years of age who are mentally and/or physically dysfunctional, living either independently in the community or with a temporarily or permanently responsible caregiver. This rule will take effect beginning January 1, 1994 and will remain in effect for the maximum of 120 days.

EMERGENCY RULE

Effective January 1, 1994, the Department of Health and Hospitals is establishing procedures to implement a protective service agency for adults between the ages of 18 and 59 who are in need of protection. This emergency rule shall remain in effect for the maximum of 120 days.

Title 48

PUBLIC HEALTH - GENERAL

Part 1. General Administration

Subpart 13. Protective Services Agency

Chapter 171. Bureau of Protective Services

§17101. Statement of Policy

A. The Department of Health and Hospitals is committed

to preserving and protecting the rights of individuals to be free from abuse, neglect, exploitation, or extortion.

B. In pursuit of this commitment and in accordance with the provisions of R.S. 14:403.2, the Department of Health and Hospitals names the Bureau of Protective Services as the Protective Services Agency in order to provide protection to individuals who are unable to independently provide for themselves and who are harmed or threatened with harm through the action or inaction of themselves or those entrusted with their care.

C. The primary function of the Bureau of Protective Services is to investigate cases consistent with the criteria contained in R.S. 14:403.2 and to use that information to identify and link individuals which the Bureau of Protective Services determines are in need of services to appropriate service providers. Bureau of Protective Services staff will provide services to each individual in need of protection until that person's situation has stabilized.

§17103. Goals and Objectives

The primary goal of the Bureau of Protective Services is to prevent, remedy, halt, or hinder abuse, neglect, exploitation, and extortion of individuals in need of services as defined in this regulation and consistent with the provisions of R.S. 14:403.2. In order to achieve this goal, the Bureau of Protective Services shall pursue the following objectives:

1. to establish a system of mandatory reporting, intake, classification, timely investigation and response to allegations of abuse, neglect, exploitation, and extortion;

2. to provide protective services to the individual while assuring the maximum possible degree of self-determination and dignity;

3. in concert with other community service and health service providers, facilitate the process toward developing individual and family capacities to promote safe and caring environments for individuals in need of protection;

4. to secure referral or admission to appropriate alternative living arrangements if all efforts to maintain the individual in his/her own home fail;

5. to assist individuals in need of protection to maintain the highest quality of life with the least possible restriction on the exercise of personal and civil rights.

6. to educate the general public, as well as private and public service agencies, regarding the Protective Services Agency and the requirements of R.S. 14:403.2.

§17105. Definitions

For the purposes of this Chapter, the following definitions shall apply:

Abuse—the infliction of physical and mental injury on an adult by other parties, including but not limited to such means as sexual abuse, exploitation, or extortion of funds or other things of value, to such an extent that his/her health, self-determination, or emotional well-being is endangered. In determining whether an injury is sufficient to endanger the health, self-determination, or emotional well-being of the adult, the following criteria shall apply:

a. with respect to physical injury, the injury must be sufficient to ordinarily require professional medical intervention beyond first-aid, or, the behavior in question must be sufficient to create a potential injury of that severity.

b. with respect to mental injury, the injury must be sufficient to ordinarily require mental health services of a clinical nature, or, the behavior in question must be sufficient to create a potential injury of that severity.

c. with respect to seclusion, acts of seclusion used in a manner where the individual is alone in a room/area from which he/she cannot leave, constitutes behavior which has the potential to result in mental injury or unwarranted restriction of the adult's self-determination.

d. with respect to use of restraints, inappropriate and unauthorized use of any chemical and/or mechanical restraints, or any type of restraint which prevents the free movement of either the arms or legs and which immobilizes the individual, shall represent potential physical or mental injury and possible violation of an individual's self-determination. Chemical and/or mechanical restraints ordered by a physician shall not constitute abuse.

Adult—any individual 18 years of age or older or an emancipated minor who, because of mental or physical dysfunction, is unable to manage his own resources, carry out the activities of daily living, or protect himself from neglect or hazardous or abusive situations without assistance from others, and who has no available, willing, and responsibly able person to assist him. For purposes of this rule, the Bureau for Protective Services will accept cases for individuals who are between 18 and 59 years of age; the Office of Elderly Affairs shall have jurisdiction for individuals 60 years of age or older.

Bureau of Protective Services (BPS) or the Bureau—that agency determined by the Department of Health and Hospitals as the Protective Services Agency, pursuant to the provisions of R.S. 14:403.2, to provide protection to adults defined above.

Caregiver—any person or persons, either temporarily or permanently responsible for the care of a physically or mentally disabled individual. Caregiver includes but is not limited to adult children, parents, relatives, neighbors, day-care personnel, adult foster home sponsors, substitute family care, personnel of public and private institutions and facilities, adult congregate living facilities, and nursing homes which have voluntarily assumed the care of an individual, have assumed voluntary residence with an individual, or have assumed voluntary use or tutelage of an individual's assets, funds, or property, and specifically shall include city, parish, or state law enforcement agencies.

Emancipated Minor—a person under the age of 18 who administers his or her own affairs or who is relieved of the incapacities which normally attach to minority. Minors can be emancipated either by notarial act, marriage, or judicial pronouncement.

Exploitation—the illegal or improper use or management of a disabled adult's funds, assets, or property, or the use of a disabled adult's power of attorney or guardianship for one's own profit or advantage.

Extortion—the acquisition of a thing of value from an unwilling or reluctant adult by physical force, intimidation, abuse, neglect, or official authority.

Neglect—the failure by a caregiver responsible for an adult's care or by other parties, to provide the proper or necessary support or medical, surgical, or any other care

necessary for his well-being. No adult who is being provided treatment in accordance with a recognized religious method of healing in lieu of medical treatment shall for that reason alone be considered to be neglected or abused.

Individual or Individual in Need of Protection—any person 18 years of age or older or an emancipated minor, who because of mental or physical dysfunction, is unable to manage his/her own affairs, carry out the activities of daily living, or protect himself from hazardous or abusive situations without assistance from others; and who has no available, responsibly able person to assist him. For purposes of this rule, BPS will accept cases for individuals who are between 18 and 59 years of age. The Office of Elderly Affairs shall have jurisdiction for individuals 60 years of age or older.

Protective Services—those activities developed to assist individuals in need of protection. Protective services include but are not limited to: receiving and screening information on allegations of abuse, neglect, exploitation or extortion; conducting investigations into those allegations to determine if the situation and condition of the alleged victim warrants corrective or other action, making recommendations, as appropriate, for preventative or corrective actions; and for case management, as needed.

Regional Coordinating Council—a regionally constituted committee composed of representatives of both public and private agencies which provide services to individuals in need of protection. These regional coordinating councils are designed to maximize resources available to individuals in need of protection particular to that region by effecting a regionally individualized plan for the allocation or reallocation of available resources, expansion of programs, or redirection of current resource allocation.

Self-neglect—the failure, either by the individual's action or inaction, to provide the proper or necessary support or medical/surgical or other care necessary for his/her own well-being. No individual who is provided treatment in accordance with a recognized religious method of healing in lieu of medical treatment shall, for that reason alone, be considered to be self-neglected.

§17107. Prohibition Against Abuse, Neglect, Exploitation, Extortion

Abuse, neglect, exploitation, or extortion of individuals in need of protection is prohibited by law R.S. 14:403.2, and if confirmed, may result in criminal charges being filed against the alleged perpetrator.

§17109. Eligibility for Services

A. The protection of this law and rule extends to all individuals living in the community, whether independently or with the help of others, who are alleged to be abused, neglected, exploited, or extorted, and are between the ages of 18 and 59 and have a mental or physical dysfunction, if these individuals:

1. cannot manage their own resources; or,
2. cannot independently complete daily living tasks; or,
3. cannot protect themselves from abuse, neglect, exploitation, extortion, or other hazardous situations; and,
4. for whom there is no other available, willing or responsibly able person to assist him.

B. There is no financial eligibility requirement for services

provided by the Bureau of Protective Services.

§17111. Reporting

A. Responsibility to Report

1. Any person having cause to believe that an individual's physical or mental health or welfare has been or may be further adversely affected by abuse, neglect, exploitation, or extortion shall report that knowledge or belief. These reports can be made to:

- a. the Bureau of Protective Services; and/or,
- b. any local or state law enforcement agency.

2. Reports of abuse, neglect, exploitation and extortion shall be processed through the DHH Bureau of Protective Services' central office reporting system. Reports should be made/forwarded to: Bureau of Protective Services, 4615 Government Street, Building B, Box 3518, Bin Number 11, Baton Rouge, LA 70821, at the telephone number, (504) 922-2600. A 24-hour toll free number shall be established to receive allegations of abuse, neglect, exploitation and/or extortion.

B. Intake. Alleged incident reports received by the bureau shall be screened to determine eligibility, and shall be assigned a priority status for investigation as described in Section 17121 of this Chapter. When reports are not accepted by the bureau, the reporter will be advised why his/her report was rejected for investigation. Such reports will be referred to other social, medical, and law enforcement agencies, as deemed appropriate.

1. Allegations of known or suspected abuse, neglect, exploitation, or extortion should include:

- a. the name and address of the alleged victim; and,
- b. the name and address of the person providing care to the alleged victim, if possible; and,
- c. other pertinent information.

2. Allegations of abuse, neglect, exploitation or extortion made by the alleged victim shall not be considered to be any less credible than allegations made by others and shall be reported according to procedures established in this Chapter.

C. Investigation. Reports accepted by the Bureau of Protective Services for investigation shall be prioritized according to Section 17121 of this rule. The subsequent investigation and assessment shall include the nature, extent, and cause of the abuse, neglect, exploitation, extortion, the identity of the person or persons allegedly responsible for abuse, neglect, exploitation, or extortion, if known; where possible, an interview with the individual and also where possible, a visit to the individual's home. Consultation with others having knowledge of the facts of the case shall also be included in the investigation. A report of the investigation shall be generated, which also contains an assessment of the individual's present condition/status.

D. Service Plan. The protective service worker will be responsible for developing a service plan based upon the case determination. If at the end of the investigation it is determined that the individual has been abused, neglected, exploited, and/or extorted by other parties, and that the problem cannot be remedied by extrajudicial means, the Bureau of Protective Services shall refer the matter to the local district attorney's office. Evidence must be presented, together with an account of the protective services given or

available to the individual, and a recommendation as to what services, if ordered, would eliminate the abuse/neglect.

E. Penalty for Failure to Report. Any person who knowingly and willfully fails to report as provided by Item A of this Section, shall be fined not more than \$500 or imprisoned not more than six months, or both. [R.S. 14:403.2.J.1]

F. Penalty for False Reporting. Any person who knowingly makes a false report of abuse, neglect, exploitation, or extortion shall be fined not more than \$1,000 imprisoned with or without hard labor for not more than one year, or both. [R.S. 14:403.2.J.2]

G. Right to Refuse Services. Protective Services may not be provided in cases of self-neglect to any individual who does not consent to such services or who, having consented, withdraws such consent. Nothing herein shall prohibit the Bureau of Protective Services, the district attorney, the coroner, or the judge from petitioning for interdiction pursuant to Civil Code, Articles 389-426.

§17113. Confidentiality

A. Information contained in the case records of the Bureau of Protective Services shall not be released without a written authorization from the involved individual or legally authorized representative, except that the information may be released to law enforcement agencies and social service agencies who are providing services to the adult or pursuing enforcement of criminal statutes, or pursuing interdiction of the individual.

B. Information about individuals in need of protection and/or information provided by others about those individuals or their caregivers or others shall only be released if:

1. the individual in need of protection or the legally authorized representative has consented to the release of the information; and/or,

2. the release of information is legally mandated, such as a required referral to local law enforcement agencies in the case of criminal acts involving an individual in need of protection, or to regulatory agencies, or when pursuing interdiction of the individual.

§17115. Immunity

A. Under the provision of R.S. 14:403.2(K) no cause of action shall exist against:

1. any person who, in good faith, makes a report, cooperates in an investigation by an agency, or participates in judicial proceedings;

2. any DHH Protective Services staff who, in good faith, conducts an investigation or makes an investigative judgement or disposition;

3. the persons listed in Paragraphs 1 and 2 of this Subsection shall have immunity from civil or criminal liability that otherwise might be imposed or incurred.

B. This immunity shall not extend to:

1. any alleged principal, conspirator, or accessory to an offense involving the abuse or neglect of the individual;

2. any person who makes a report known to be false or with reckless disregard for the truth of the report;

3. any person charged with direct or constructive contempt of court, any act of perjury as defined in Subpart C of Part VII of the Louisiana Criminal Code or any offense

affecting judicial functions and public records as defined in Subpart D of Part VII of the Louisiana Criminal Code.

§17117. The Department of Health and Hospitals' Protective Services System

A. The department will deliver protective services through direction and oversight by a centrally located Bureau of Protective Services to the department's nine regional offices.

B. The department will be responsible for delivery of services to adults through the established regional office in the region in which the adult resides.

§17119. Responsibilities of Regional Coordinating Councils

A. The Bureau of Protective Services shall create regional coordinating councils in each region of the state to coordinate community services in support of individuals in need of protection.

B. These councils will have as their objective to achieve maximum community coordination by efforts to:

1. identify resources, both in common to the agencies represented and available from outside resources; and,
2. increase availability of needed services by maximizing existing resources and decreasing duplication of effort;
3. assure maximum community coordination of effort in providing necessary services.

§17121. Priorities for Case Response

In order to assure the timely delivery of protective services and to eliminate the potential danger of prolonging an abusive situation, a priority system for case response has been established. At the time a report of abuse is received in the Bureau of Protective Services, the report will be prioritized and assigned for investigation based on the criteria set forth below.

1. Priority One

a. Priority One reports are those which allege the individual in need of protection is abused, neglected, exploited, or extorted, and has suffered serious harm or serious physical injury which, if untreated, may result in permanent physical damage or death.

b. Examples of Priority One reports include but are not limited to head injuries, spinal injuries, severe cuts, broken limbs, severe burns, and/or internal injuries and sexual abuse where there is danger of repeated abuse, situations where medical treatment, medications or nutrition necessary to sustain the individual are not obtained or administered, as well as over-medication and unreasonable confinement.

c. Staff must respond to Priority One cases within 24 hours of receipt by the Bureau of Protective Services. For purposes of this Section, "case response" means that the investigator must attempt a face-to-face visit with the individual in need of protection within this 24-hour period.

2. Priority Two

a. Priority Two reports allege the individual in need of protection is abused, neglected, exploited, or extorted, and as a result, is at risk of imminent serious physical injury or harm.

b. Priority Two reports may include but not be limited to those situations in which there is failure to provide or obtain mental health and medical treatment which, if untreated, may cause serious harm to the individual. This includes, self-abusive behavior, and failure to treat physical ailments. It

could also include inadequate attention to physical needs such as insufficient food, medicine, inadequate health or excessive heat, unauthorized use, and/or exploitation of the victim's income or property.

c. Staff must respond to Priority Two cases within five working days of receipt by the Bureau of Protective Services. For purposes of this Section, "case response" means that the investigator must attempt a face-to-face visit with the individual in need of protection within a five-working-day period, so long as the investigation of Priority One cases is not delayed.

3. Priority Three

a. Priority Three reports include all other allegations in which the individual in need of protection is alleged to be abused, neglected, exploited, and extorted which do not involve risk of imminent serious physical injury or harm and poses no immediate threat of serious injury or harm.

b. Staff must respond to Priority Three cases within 10 working days of receipt by the Bureau of Protective Services. For purpose of this section, "case response" means that the investigator must attempt a face-to-face interview with the individual in need of protection within this ten day working period, so long as the investigation of Priority One and Two cases are not delayed.

§17123. Training

To encourage prompt reporting of suspected abuse, neglect, exploitation, or extortion, Bureau of Protective Services staff shall provide for and/or participate in activities to inform the general public and, in particular, targeted professionals and service providers about the Protective Services Program.

§17125. Dissemination

A. A copy of this rule shall be made available to anyone, including individuals in need of protection, upon request.

B. Copies of this rule shall be disseminated to public areas of state and local agencies which target populations of persons who are mentally, physically, or emotionally challenged (including but not limited to community services offices of the Office of Citizens with Disabilities, Office of Mental Health, Office of Public Health and Office of Alcohol and Drug Abuse, state and local law enforcement agencies, advocacy agencies, nursing homes, hospitals, private care agencies, and other related service agencies).

Interested persons may submit written comments to the following address: Carolyn Maggio, Office of the Secretary, Bureau of Research and Development, Box 2870, Baton Rouge, LA 70821-2870. She is responsible for responding to inquiries regarding this emergency rule and providing information about a public hearing on this matter.

Rose V. Forrest
Secretary

DECLARATION OF EMERGENCY

Department of Insurance Commissioner of Insurance

Regulation 51—Individual Health Insurance Rating Requirements

In accordance with the provisions of R.S. 49:953(B) et seq. of the Administrative Procedure Act the Commissioner of Insurance has adopted emergency Regulation 51 in order that it might be implemented without delay and within the time limits set forth in Act 655 of the 1993 Regular Legislative Session.

Emergency rulemaking is necessary to immediately provide for a modified community rating system to be followed by carriers marketing individual health and accident insurance policies. This emergency rule will remain in effect for 90 days or until the rule becomes final.

EMERGENCY REGULATION 51

Individual Health Insurance Rating Requirements

Section 1. Purpose

The purpose of this rule is to facilitate the implementation of R.S. 22:228.6. The intent of R.S. 22:228.6 is to establish a modified community rating system for health care premiums in the state. Adherence to this rule by individual health and accident insurance carriers will bring carriers into compliance with Section 22:228.6. The provisions of R.S. 22:228.6 not specifically addressed in this rule are in full force and effect as if they were addressed herein.

Section 2. Authority

This regulation is issued pursuant to the authority vested in the Commissioner of Insurance under the Administrative Procedure Act, R.S. 49:950 et seq., and R.S. 22:10 and 22:228.6 of the Insurance Code.

Section 3. Applicability and Scope

R.S. 22:228.6 applies to the rating of small group and individual health benefit plans. This particular regulation applies to the compliance of individual health benefit plans only.

Section 4. Definitions

Individual Policy—any hospital, health or medical expense insurance policy, hospital or medical services contract, health and accident insurance policy, or any other insurance contract of this type covering any one person with or without eligible family members. Not included under this definition are continuation or conversion policies, or insurance policies written to cover specified disease, hospital indemnity, accident only, credit, dental or disability income, Medicare supplementary or long-term care, or other limited, supplemental benefit insurance policies. "Individual policy" also means a policy issued to an individual or individual member of an association where the individual pays for the entire premium.

Manual Rate—the lowest premium rate charged or which could have been charged under a rating system by the carrier to individuals with similar case characteristics for health benefit plans with the same or similar coverage. Coverage and case characteristic variations in the manual must bear a

reasonable relationship to normal expectations based on experience of standard risks. The use of experience alone is not sufficient justification for variations beyond such expectations.

Section 5. Restrictions on Premium Rates

A. Each individual health and accident insurance carrier shall define a rate manual for its individual business. The manual will be used to determine compliance with the intent of the law for the relationship of one individual to the others within a carrier's block of individual business. For the purpose of this rule, all individual business shall be considered one class, and that class shall not be subject to R.S. 22:228.2.A.(1).

B. R.S. 22:228.6.b(2)(e), requires, in substance, that the premium rates charged during a rating period to individuals may not vary from the index rate by more than 20 percent for two years following January 1, 1994 and 10 percent thereafter. This requirement shall be met for each individual if the ratio of the premium charged the individual to that calculated from the rate manual is between 1 and 1.5 for rating periods following January 1, 1994 through January 1, 1996 and between 1 and 1.22 for rating periods thereafter.

C. For individual health insurance, the acceptability of a proposed rate increase for an individual contract or certificate shall be determined by comparing the desired renewal premium to a maximum renewal premium calculated as follows:

1. Calculate a premium using manual rates for the individual from the rate manual in effect at the renewal date, based on the case characteristics of the individual and the current benefit plan.

2. For rating periods following January 1, 1994 through January 1, 1996, the maximum renewal premium is 1.5 times the manual rate in C.1. For rating periods beginning after January 1, 1996, the maximum renewal premium is 1.22 times the manual rate in C.1.

3. In cases where the individual policy or contract does not have a specified renewal date, the anniversary of the date of issue shall be used as a proxy for the renewal date.

Section 6. General Provisions

A. Other methods may be used if it is demonstrated to the satisfaction of the department that such methods are designed to attain and/or enhance the purposes of R.S. 22:228.6. Such a demonstration shall at least consist of an actuarial certification and the methodology for testing compliance with R.S. 22:228.6.

Interested parties may submit comments on the regulation until 4:30 p.m., January 14, 1994 to: C. Noël Wertz, Senior Attorney, Box 94214, Baton Rouge, LA 70804-9214.

James H. "Jim" Brown
Commissioner of Insurance

DECLARATION OF EMERGENCY

Department of Insurance Commissioner of Insurance

Regulation 52—Small Group Health Insurance Rating Requirements

In accordance with the provisions of R.S. 49:953(B) et seq. of the Administrative Procedure Act the Commissioner of Insurance has adopted Regulation 52 in order that it might be implemented without delay and within the time limits set forth in Act 655 of the 1993 Regular Legislative Session. The regulation implements a modified community rating system for small group health insurance carriers. This emergency rule will remain in effect for 90 days.

EMERGENCY REGULATION 52

Small Group Health Insurance Rating Requirements

Section 1. Purpose

The purpose of this rule is to facilitate the implementation of R.S. 22:228.2 and 22:228.6. The intent of R.S. 22:228.2 is to restrict premium rate increases and the intent of R.S. 22:228.6 is to establish a modified community rating system for health care premiums in the state. Adherence to this rule by small employer health and accident insurance carriers will bring them into compliance with R.S. 22:228.2 and 22:228.6. The provisions of R.S. 22:228.2 and R.S. 22:228.6 not specifically addressed in this rule are in full force and effect as if they were addressed herein.

Section 2. Authority

This regulation is issued pursuant to the authority vested in the Commissioner of Insurance under the Administrative Procedure Act, R.S. 49:950 et seq., and R.S. 22:10, 22:228.2 and 22:228.6 of the Insurance Code.

Section 3. Applicability and Scope

R.S. 22:228.2 applies to the rating of small group health benefit plans only. R.S. 22:228.6 applies to the rating of small group and individual health benefit plans. This particular regulation applies to the compliance of small group health benefit plans and association sponsored plans where group and individual member plans are combined.

Section 4. Definitions

Manual Rate—for each class of business as to a rating period, the lowest premium rate charged or which could have been charged under a rating system for that class of business, by the carrier to small employers with similar case characteristics for health benefit plans with the same or similar coverage. Coverage and case characteristic variations in the manual must bear a reasonable relationship to normal expectations based on experience of standard risks. The use of experience alone is not sufficient justification for variations beyond such expectations.

Representative Census—the average characteristics of all groups in a class of business insured by an insurance carrier.

Small Group and **Small Employer**—any person, firm, corporation, partnership or association actively engaged in business which, on at least fifty percent of its working days during the preceding year, employed no less than three nor more than 35 eligible employees or association members and

does not include policies whose premiums are paid for by the individual employee alone. However, any association sponsored plan, which includes a combination of small groups and individuals, shall be considered as a small group and governed under Sections 22:228.2 and 22:228.6.

Section 5. Restrictions on Premium Rates

A. Each class of business shall have its own rate manual. The manual will be used to determine compliance with the intent of the law for the relationship of one employer group to the others within a class. The rate manual will also be used to determine compliance with the required relationship of one class to the other classes.

B. R.S. 22:228.2.A(2) and R.S. 22:228.6.B(2)(e) requires, in substance, that within a class the premium rates charged to small employers during a rating period may not vary from the index rate by more than 20 percent for two years following January 1, 1994 and 10 percent thereafter. This requirement shall be met for each small employer if the ratio of the premium charged the employer to that calculated from the rate manual is between 1 and 1.67 for rating periods from September 30, 1992 through December 31, 1993, between 1 and 1.5 for rating periods from January 1, 1994 through January 1, 1995 and between 1 and 1.22 for rating periods thereafter.

C. R.S. 22:228.2.A.(1) requires, that "the index rate for a rating period for any class of business shall not exceed the index rate for any other class of business by more than 20 percent." This requirement shall be met as follows:

1. The company shall define a representative census of its business.

2. On December 31 of each calendar year, the company shall calculate a dollar rate according to the manual rate in effect for the rating period beginning December 31 for each class, using an actuarially equivalent plan of benefits for the representative census.

3. A conversion to an index dollar rate shall be made from the manual dollar rate for each class calculated in C.2 above. This conversion shall be made by multiplying the manual dollar rate for each class in C.2 above, by the appropriate factor for each class calculated as follows:

i. Calculate the ratio of the highest premium charged or which could have been charged as of the last renewal or issue date, according to the description of the rating practices for that class as required by 22:228.5, to the manual rate in effect at the last renewal or issue date for each group still in force as of December 31.

ii. The sum of 1.00 plus the highest ratio calculated from C.3.i. above divided by two shall be used as the conversion factor in C.3 above. For the calendar year 1993, if the highest ratio calculated in C.3.i. above is greater than 1.67, then 1.67 shall be used as the highest ratio. This conversion factor should be calculated for each class of business. For calendar years 1994 and 1995, 1.5 shall be used above. For each year thereafter, 1.22 shall be used.

4. The ratio of the highest index dollar rate for any class cannot exceed the lowest index dollar rate for any other class calculated in C.3. by more than 20 percent.

5. This test shall be performed on December 31 every year. Other methods may be used if it is demonstrated to the

satisfaction of the department that the result will be the same.

D. R.S. 22:228.2.A.(3)(a)-(c) limits the percentage increase in the premium rate charge to small employers for a new rating period. In capsule form, the increase may not exceed the sum of the following:

1. the percentage change in the new business premium rate;
2. an adjustment, not to exceed 15 percent annually and prorated for rating periods of less than one year due to the claims experience, health status, or duration of coverage of the employees or dependents of the small employer; and
3. any adjustments due to change in coverage or case characteristics of the small employer.

E. The limit of a proposed rate increase for a small employer shall be determined by comparing the desired renewal premium to a maximum renewal premium calculated as follows:

1. Calculate a premium using manual rates for the small employer from the rate manual in effect at the renewal date, based on the current census of the small employer and the current benefit plan.

2. Calculate a premium using manual rates for the small employer from the rate manual in effect at the beginning of the rating period, based on the census and the benefit plan then in effect or based on the current plan with an actuarially equivalent adjustment for the difference in benefits between plans.

3. E.1 divided by E.2 multiplied by the gross premium in effect at the beginning of the rating period gives the maximum renewal premium for the next rating period for the allowance of D.1 and D.3 above.

4. A percentage of the gross premium in force prior to renewal may be added to E.3. The percentage is 15 percent per year prorated for the months elapsed between the last and current rating dates.

5. E.3 plus E.4 is the maximum renewal premium subject to the following:

- i. Calculate the ratio of the maximum renewal premium in 5 above to the manual rate in E.1.

- ii. For rating periods through December 31, 1993, if i exceeds 1.67, then 1.67 multiplied by the manual rate in E.1. is the maximum renewal premium, not the renewal premium in E. For rating periods after December 31, 1993 through December 31, 1995, 1.5 should be substituted for 1.67. For rating periods beginning on or after January 1, 1996, 1.22 should be substituted in the above for 1.67.

Section 6. General Provisions

A. Other methods may be used to comply with R.S. 22:228.2 and R.S. 22:228.6 if it is demonstrated to the satisfaction of the department that such methods are designed to attain and/or enhance the purposes of R.S. 22:228.2 and R.S. 22:228.6. Such demonstration shall at least consist of an actuarial certification and the methodology for testing compliance with R.S. 22:228.2 and R.S. 22:228.6.

James H. "Jim" Brown
Commissioner of Insurance

DECLARATION OF EMERGENCY

Department of Labor
Office of Labor

Community Services Block Grant
(LAC 40:XVII.Chapters 29 and 49)

In accordance with the emergency provisions of R.S. 49:953(B), of the Administrative Procedure Act, the Louisiana Department of Labor declares that rules and regulations of the Office of Labor are hereby adopted to be effective December 20, 1993, for 120 days or until the final rule is adopted, whichever occurs first.

Federal law mandates that a state hold a hearing prior to termination of CSBG funding. Consistent with this mandate the state is adopting the following rules implementing a procedure to hold a hearing and establish due process guidelines prior to the termination of CSBG funding for a Community Action Agency.

The notice of intent and the final promulgation of CSBG rules will be completed in accordance with the Administrative Procedure Act after December 20, 1993.

Title 40

LABOR AND EMPLOYMENT

Part XVII. Community Services Block Grant

Chapter 29. Appeal of Termination of Funding

§2901. Termination of Funding; Appeal

A. Termination Notice. The Department of Labor will notify the agency in writing of the intention to terminate funding, and shall state the reasons for the termination.

B. An agency has the right to request a hearing prior to termination of funding. The request for a hearing must be filed within five days of the notice of intention to terminate funding.

C. The hearing will be held in accordance with the procedures outlined in §2903.

AUTHORITY NOTE: Promulgated in accordance with R.S. 23:61 et seq.

HISTORICAL NOTE: Promulgated by the Department of Labor, Office of Labor, LR 20:

§2903. Selection of Hearing Officer and Responsibilities

A. Specific person(s) should be identified by the Department of Labor to function in a quasi-judicial capacity in relation to the hearing process. Each party will be notified as to the hearing officer(s) selected to conduct their appeal or hearing at least 10 days prior to the hearing. Standards to be applied in selection of these persons are as follows:

1. They should have independence in obtaining facts and making decisions.

2. The hearing officer(s) must be in a position to render impartial decisions that are fair.

B. If either party to the complaint is aware of facts or circumstances which put the designated hearing officer's independence and impartiality in question, the appointing body should be notified within five days of receiving notice. An alternate(s) will be appointed if deemed appropriate by the Department of Labor. In all cases, documentation regarding the allegation and how it was handled should be included in the file.

C. Responsibilities within the scope of the designated hearing officer(s) are:

1. directs preparation of and reviews a complete file on the case prior to the hearing;
2. directs parties to appear at hearing;
3. holds hearing;
4. receives evidence;
5. disposes of procedural requests;
6. questions witnesses and parties, as required;
7. considers and evaluates facts, evidence and arguments to determine credibility;
8. renders decision and issues it in writing to all parties involved; and
9. provides the complete record including:
 - a. all pleadings, motions and intermediate rulings;
 - b. detailed minutes of the oral testimony plus all other evidence received or considered;
 - c. a statement of matters officially noted;
 - d. all staff memoranda or data submitted to the decision maker in connection with their consideration of the case;
 - e. findings of fact based on the evidence submitted at the hearing; and
 - f. notification of further appeal procedures, if applicable;
 - g. final decision of the hearing officer.

D. The hearing may be conducted informally. Unnecessary technicalities (e.g., legal requirements that would be appropriate in court proceedings) should be avoided. It will provide the flexibility to enable adjustment to the circumstances presented. The following guidance is provided in respect to the hearings.

1. Full regard should be given to the requirements of due process to ensure a fair and impartial hearing.

2. All testimony at any hearing before the hearing officer(s) designated at the state level shall be mechanically recorded.

3. The hearing officer should begin the hearing by summarizing the record and the issues, affording both parties an opportunity to review such record, and should explain the manner in which the hearing will be conducted, making sure that everyone involved understands the proceedings. Such explanation should be adapted to the needs of the specific situation. The hearing officer shall take testimony under oath or affirmation to give some assurances of veracity to the hearing.

4. The burden of proof should be reasonable and flexible, dependent upon the circumstances of the case involved. The hearing officer(s) determines the order of proof. Generally, the agency making the complaint has the obligation of establishing its case, and should be examined first.

5. The parties involved may be represented, but are responsible for securing such representation. Otherwise, he/she is limited to his/her own abilities and those of the hearing officer(s) in obtaining testimony in the case.

6. It is important that the hearing officer(s) obtain the fullest information for the record. If the parties involved, or their representatives, do not know how to ask the right or pertinent question, in pursuing their right to due process, it

shall be necessary for the hearing officer(s) to assist in having all the material and relevant facts elicited.

7. The practice in informal hearings is generally not to apply strict rules of evidence in obtaining facts. However, the quantity of evidence required to support a decision on an issue should be sufficiently credible that a court upon reviewing the decision, would conclude that it is supported by substantial evidence.

8. The general rules in law should be applied in decision on remedies, which should be reasonable and fit the problem and/or violation.

9. The hearing officer(s) may accept any resolution of the issue agreeable to all parties at any time prior to the rendering of a decision, as long as such agreement does not violate state or federal law.

AUTHORITY NOTE: Promulgated in accordance with R.S. 23:61 et seq.

HISTORICAL NOTE: Promulgated by the Department of Labor, Office of Labor, LR 20:

§2905. Hearing Notice

The procedure required to hold a hearing shall include reasonable notice by registered or certified mail, or by hand with signature indicating receipt. The notice will include:

1. statement of the time and place of hearing;
2. the identity of the hearing officer;
3. a statement of the authority and jurisdiction under which the hearing is to be held;
4. a reference to the particular section of the Act, regulations, grant or other agreements under the Act involved;
5. notice to the parties of the specific charges involved;
6. the right of both parties to be represented by legal counsel;
7. the right of each party to bring witnesses and/or documentary evidence; and
8. the right of each party to cross examination.

AUTHORITY NOTE: Promulgated in accordance with R.S. 23:61 et seq.

HISTORICAL NOTE: Promulgated by the Department of Labor, Office of Labor, LR 20:

§2907. Decision; Appeal

A. The hearing officer shall render a decision within 10 days after the hearing is held. Written notification of the decision shall be mailed to the interested parties. The decision will become final within 15 days unless an appeal is filed.

B. The agency may appeal the decision to the secretary of the U.S. Department of Health and Human Services within 15 days after the receipt of the decision. If no appeal is filed, the decision is final.

AUTHORITY NOTE: Promulgated in accordance with R.S. 23:61 et seq.

HISTORICAL NOTE: Promulgated by the Department of Labor, Office of Labor, LR 20:

Chapter 49. Personnel Provisions

§4903. Disputes and Appeals

A. Disputes. Any disputes which may arise in the negotiation of subgrants or the operation of activities as described in the subgrant, shall be brought to the attention of the state director of the CSBG programs. All efforts will be made to resolve the disputes, and the director shall provide a decision in writing to the subgrantee.

B. Review. In the event the subgrantee does not agree with the determination of the director of CSBG programs, a written appeal may be filed to the secretary of labor or designee for review. The appeal must be in writing, and must be filed within 15 days after the receipt of a determination from the director of CSBG programs. The appeal must contain the reasons for the appeal, and a description of the relief sought. The grant officer shall, within 30 days of the receipt of the appeal, issue a written decision. This decision shall be final.

C. Changes to Special Clauses. The special clauses may be changed and/or amended by the grantor to comply with changes in federal and state laws and regulations or changes in operational policies of the grantor. Changes shall be provided to the subgrantee in writing, and shall become effective on the date of notification.

D. Legal Remedies. In the event of either party's breach or default, the other party shall be entitled to exercise all rights and pursue all remedies available under Louisiana law.

E. Access to Documentation. The subgrantee hereby agrees to the provision of granting access to any books, documents, paper, and records of the subgrantee which are directly pertinent to this particular contract to the owner, federal grantor agency, the Comptroller General of the United States, or any of their duly authorized representatives. Also, the subgrantee agrees to maintain all required records for five years after the state makes final payment and all other pending matters are closed.

AUTHORITY NOTE: Promulgated in accordance with R.S. 23:61 et seq.

HISTORICAL NOTE: Promulgated by the Department of Labor, Office of Labor, LR 20:

Gayle Truly
Secretary

DECLARATION OF EMERGENCY

Department of Public Safety and Corrections Board of Pardons

Sex Offenders (LAC 22:IX)

The Department of Public Safety and Corrections, Board of Parole, has exercised the emergency provision of the Administrative Procedure Act, R.S. 49:953(B), in order to implement Acts 388 and 962 of the 1992 Regular Legislative Session and adopts the following emergency rule, effective December 20, 1993.

Emergency rulemaking is necessary in order to protect and insure the safety of the public now that sex offenders are being released and residing in the community.

This emergency rule shall remain in effect for 120 days or until a final rule is promulgated, whichever comes first.

Title 22

CORRECTIONS, CRIMINAL JUSTICE AND LAW ENFORCEMENT

Part XI. Board of Parole

A. Purpose. The purpose of this regulation is to set forth

procedures to be followed for notification, disclosure and dissemination of the information regarding sex offenders.

B. Responsibility. The Louisiana Board of Parole and the Department of Public Safety and Corrections, Division of Probation and Parole are responsible for ensuring implementation of this regulation.

C. Definitions

He—all forms of masculine pronouns are used. This is intended to refer to either sex and is used as a matter of convenience.

Louisiana Board of Parole—the board.

Sex Offender—a person who has violated any of the following offenses, or the equivalent offense in another jurisdiction:

Abetting in Bigamy;
Forcible Rape;
Aggravated Crime Against Nature;
Incest;
Aggravated Oral Sexual Battery;
Indecent Behavior with a Juvenile;
Intentional Exposure to AIDS;
Aggravated Rape;
Molestation of a Juvenile;
Aggravated Sexual Battery;
Oral Sexual Battery;
Bigamy;
Pornography Involving a Juvenile;
Carnal Knowledge of a Juvenile;
Sexual Battery;
Crime Against Nature;
Simple Rape;

NOTE: Attempted offenses do not fall under these rules unless specifically required by the sentencing judge or the parole board.

D. Notification

1. All sex offenders residing in this state must notify the following, of their, name, address, place of employment, crime for which he was convicted, the date and place of such conviction, any alias used by him and his social security number.

- a. police department in area he will reside;
- b. sheriff department in area he will reside.

2. A sex offender shall within 30 days of being placed on probation or released on parole or within 45 days of establishing residence in Louisiana, notify the agencies listed in D.1.a through b.

3. A sex offender cannot change his address without prior notification to his probation and parole specialist and without the prior approval of his probation and parole specialist.

4. A sex offender, changing his residence must send written notice to the agencies listed in D.1.a through b within 10 days of the change of residence if in the same parish. If the move is to a new parish, the sex offender must register with the agencies listed in D.1.a through b within 10 days of establishing his new residence.

5. The board shall send written notice at least 10 days prior to parole, community placement or work release placement to the following:

- a. the chief of police of the city in which a sex

offender will reside or be placed for work release;

b. the sheriff of the parish in which a sex offender will reside or be placed for work release;

c. if requested in writing, the board shall also send notice to the following:

i. the victim of the crime or if the victim is under 16 to the parents, tutor or legal guardian of the child;

ii. any witnesses who testified against the sex offender;

iii. any person specified in writing by the prosecuting attorney.

E. Notification - Victim Under 18 Years Old

1. The board shall mail notice, within three days of its decision to release a sex offender, to the victim or the victim's parent or guardian if they were not present at the parole hearing of the following:

a. the address where the sex offender will reside;

b. a statement that the sex offender will be released on parole; and

c. the date the sex offender will be released.

2. Sex offenders, whose victims were under the age of 18 at the time of the commission of the crime, must meet all requirements of Subsection D above as well as the following:

a. a sex offender must give notice of the crime, his name and address by mail to the following:

i. all persons residing within a three square block area or a one square mile area if in a rural area in accordance with Form A;

ii. superintendent of public schools in the area he will reside;

iii. heads of all parochial and private schools in the area he will reside;

iv. child protective services in the area he will reside.

b. the above must be done within 30 days of either sentence to probation, release or parole, or acceptance by Louisiana through the Interstate Compact.

c. a sex offender shall publish notice of his name, address and crime for which he was convicted and paroled, on two separate days in the official journal of the governing authority of the parish where the sex offender will reside, in accordance with Form B.

d. the board may order any form of notice they deem necessary.

F. Additional Conditions:

1. All sex offenders shall be subject to the same conditions as any other offender released on probation, parole, good time/parole supervision, work release, as well as those set forth above.

2. All sex offenders shall be subject to any special conditions as required by the board.

G. Term:

1. All sex offenders must comply with these requirements for a period of 10 years after the conviction, if not imprisoned during that period in a penal institution, full-time residential treatment facility, hospital, or other facility or institution pursuant to the conviction. If the person required to register is imprisoned or confined to a penal institution, full-time residential facility, hospital, or other facility or institution pursuant to the conviction, he shall comply with the

registration provision for a period of 10 years after release from his confinement or imprisonment. A convicted sex offender's duty to register terminates at the expiration of 10 years from the date of initial registration, provided that, during the 10-year period, he is not convicted of another sex offense.

2. All sex offenders may petition the court to be relieved of the duty to register. The petition shall be made to the court in which the petitioner was convicted of the offense that subjects him to the duty to register, or, in the case of convictions in other states, to the district court of the parish in which the person is registered. The district attorney of the parish shall be named and served as the defendant in any such petition. The court shall consider the nature of the sex offense committed, and the criminal and relevant noncriminal offense committed, and the criminal and relevant noncriminal behavior of the petitioner both before and after conviction, and may consider other factors. The court may relieve the petitioner of the duty to register only if the petitioner shows, with clear and convincing evidence, that future registration of the petitioner will not serve the purpose.

H. Release of Information

1. The board is authorized to release to the public the following information regarding sex offenders:

a. name;

b. address;

c. crime convicted and paroled;

d. date of conviction;

e. date of release on parole or diminution of sentence;

f. any other information that may be necessary and relevant for public protection.

2. The board can not release any information regarding victims or witnesses of sex crimes to the sex offender or the general public.

3. Verbal requests of information are acceptable. The chairman of the Board of Parole or his designated representative reserves the right to require a written request before releasing any information.

FORM "A"

STAMPED POST CARD

Under Louisiana Sex Offender laws, LA R.S. 15:540, et seq., and 15:574.4, I am required to notify you of the following information:

NAME: _____

ADDRESS: _____

OFFENSE OF CONVICTION: _____

These postcards will be stamped with your Probation and Parole Officer's return address. Prior to mailing, the Probation and Parole Officer will examine the cards for complete and correct information and to ensure that the appropriate number of postcards are being mailed.

FORM "B"

Under Louisiana Sex Offender laws, LA R.S. 15:540, et seq., and 15:574.4, I am required to provide the following information:

NAME: _____

ADDRESS: _____

OFFENSE OF CONVICTION: _____

You will present this completed form to the official publication(s) in your area, fill in their name and address, pay to have the ad run for two days, and return your receipt for payment for your Probation and Parole Officer. Additionally, you will obtain newspapers printed on the dates that your ad is run and present them to your Probation and Parole Officer as proof of publication.

_____	_____
Name of Publication	Name of Publication
_____	_____
Address	Address
_____	_____
City/State/Zip Code	City/State/Zip Code

AUTHORITY NOTE: Promulgated in accordance with R.S. 15:540 et seq. and R.S. 15:574.4.

HISTORICAL NOTE: Promulgated by the Department of Public Safety and Corrections, Board of Parole, LR 20:

Ronald Bonvillian
Chairman

DECLARATION OF EMERGENCY

**Department of Public Safety and Corrections
Office of Alcoholic Beverage Control**

Fairs, Festivals and Special Event Permits
(LAC 55:VII.323)

In accordance with R.S. 49:953(B) and under the authority conferred by Title 26 of the Revised Statutes in general, and R.S. 26:793 in particular, the Department of Public Safety and Corrections, Office of Alcoholic Beverage Control is adopting the following emergency rule to repeal the emergency rule which was published in the October, 1993 *Louisiana Register* on pages 1295 and 1296.

The Office of Alcoholic Beverage Control issued a final rule on June 20, 1991 on fairs, festivals, and special events. This rule regulated the issuance of special event permits and this rule regulated prohibited acts.

Subsequently, on September 13, 1993, the Office of Alcoholic Beverage Control adopted an emergency rule. This emergency rule was published in the October, 1993 *Louisiana Register*. This emergency rule prohibited contributions or sponsorships between wholesaler and special event permit holders. The Office of Alcoholic Beverage Control now finds

it necessary to discontinue the emergency rule in its entirety. Therefore, the Office of Alcoholic Beverage Control repeals the emergency rule promulgated in the October 20, 1993 issue of the *Louisiana Register* dealing with fairs, festivals, and special event permits. The provisions of the earlier June 20, 1991 final rule will continue to govern fairs, festivals, and special events.

EMERGENCY RULE

Effective November 23, 1993, the Department of Public Safety and Corrections, Office of Alcoholic Beverage Control is repealing the October 20, 1993 fairs, festivals, and special events permit emergency rule in its entirety.

Raymond Holloway
Assistant Secretary

DECLARATION OF EMERGENCY

**Department of Revenue and Taxation
Sales Tax Division**

Automobile Rentals; Allocation of Use Tax
(LAC 61:I.4307)

As authorized by R.S. 47:303(B)(6) and in accordance with R.S. 49:950(B) of the Administrative Procedure Act, the Department of Revenue and Taxation adopts an emergency rule amending LAC 61:I:4307 to provide for the allocation of the local sales and use taxes paid on automobiles purchased for lease or rental to each automobile rental contract. This emergency rule is effective January 1, 1994 and shall remain in effect for 120 days or until the final rule takes effect through the normal promulgation process, whichever is shortest.

Act 569 of the 1993 Regular Session of the Louisiana Legislature, effective July 1, 1993, requires the department to promulgate rules to provide for an allocation schedule that will ensure an equitable allocation that is not in excess of the actual local sales taxes paid by the lessors and renters. Given the effective date of the act, the department has determined that delay in the implementation of this rule might adversely impact the car rental industry and affect the safety, health or welfare of the public in general.

Title 61

REVENUE AND TAXATION

**Part I. Taxes Collected and Administered
by the Secretary of Revenue and Taxation**

Chapter 43. Sales and Use Tax

§4307. Collection

A. - B.4.h.ii. ...

(a).(i). Every dealer who is registered for, collects, and remits the Automobile Rental Excise Tax levied by R.S. 47:551 to the secretary of Revenue and Taxation is permitted, under the provisions of this Section, to recover the local sales taxes paid on purchases of automobiles held for rental periods of 29 days or less. In accordance with R.S. 47:303(B)(6), only those lessors or renters subject to the three percent excise tax

may directly transfer the cost of local sales and use taxes paid on any such automobiles by allocating a portion to each individual rental contract. Lessors or renters whose lease or rental contracts exceed 29 days and whose lease or rental receipts are not subject to the three percent excise tax are not eligible for this recovery provision.

(ii). This provision merely makes this recovery option available to any qualified automobile rental dealer. It is not mandatory, and rental dealers who do not wish to employ this recovery method are not required to comply with this regulation.

(iii). Any and all sales or use taxes levied by political subdivisions of Louisiana under the provisions of Title 33, Chapter 6, Part I, Subpart D, and paid to the Office of Motor Vehicles on purchases of automobiles whose rental receipts are subject to the three percent tax levied under R.S. 47:551 are recoverable under this provision. Sales taxes levied by the State of Louisiana, any other state, or by political subdivisions of any other state are not recoverable. Local sales and use taxes paid on any type of vehicles other than automobiles, vehicle registration taxes, title and service fees, occupational license taxes, privilege taxes, or ad valorem taxes are not eligible for recovery under this Section.

(b). In order to accomplish and facilitate collection of local sales taxes due, an amount equal to the Local Sales Tax Recovery Surcharge (LSTRS) of \$2 per rental day shall be collected and retained by the owner/lessor of the vehicle from the person/lessee renting the vehicle. Rental transactions having a duration of less than 24 hours shall be considered a rental day for purposes of collecting the LSTRS. The vehicle owner/lessor must collect the LSTRS as a line item on the customer invoice, which is separate from the state and local sales and use tax and the Automobile Rental Excise Tax. The vehicle owner/lessor must not represent the LSTRS to his lessees as a charge that is mandated by the State of Louisiana or by any political subdivision of the state.

(c). The owner/lessor shall remit the sums for local sales taxes due to the vehicle commissioner in the usual and customary manner as provided by law.

(d).(i). To provide for an orderly transition to the local sales tax recovery system established in R.S. 47:303 (B)(6), each automobile owner/lessor shall, before adding the LSTRS to any rental contract, determine the total amount of local sales and use tax that he paid in the prior calendar year on automobiles held for rental periods of 29 days or less. The automobile owner/lessor must cease the collection of the LSTRS from lessees at the time that total collections from the LSTRS during the current calendar year equal the amount of local sales and use taxes paid on eligible vehicles during the preceding calendar year.

(ii). If, notwithstanding the provisions of (i) of this Subclause, actual collections of the LSTRS during a calendar year exceed the amount needed to reimburse the lessor for recoverable local taxes paid during the preceding calendar year, any such excess must be remitted to the Department of Revenue and Taxation as "excess tax" on the lessor's monthly return for the Automobile Rental Excise Tax.

AUTHORITY NOTE: Promulgated in accordance with R.S. 47:303(B)(6).

HISTORICAL NOTE: Promulgated by the Department of Revenue and Taxation, LR 13:107 (February 1987), amended by the Department of Revenue and Taxation, Sales Tax Division, LR 20:

Raymond Tagney
Director

DECLARATION OF EMERGENCY

Department of Social Services Office of Family Support

Child Support Non-IV-D Program (LAC 67:III.Chapter 28)

The Department of Social Services, Office of Family Support, has exercised the emergency provision of the Administrative Procedure Act, R.S. 49:953(B) to adopt the following rule effective January 1, 1994 in the Support Enforcement Services Program. The emergency rule will remain in effect for 120 days. Emergency rulemaking is necessary because, pursuant to federal regulation, R.S. 9:303 directs the department to create by January 1, 1994 a mechanism to receive and distribute child support payments for immediate income assignment orders on non-IV-D cases, that is, cases not already enforced by the Department of Social Services.

Title 67

SOCIAL SERVICES

Part III. Office of Family Support

Subpart 4. Support Enforcement Services

Chapter 28. Non-IV-D Program

Subchapter A. Non IV-D Case Administration

§2801. General Provisions

A. In all new child support orders issued after January 1, 1994, not being enforced by the Department of Social Services, payments for immediate income assignment orders shall be made payable through the Department of Social Services, Office of Family Support, Support Enforcement Services, or through the court designated to collect monies on behalf of the department. Services provided are limited to accepting payments through immediate income assignment, distributing those payments, maintaining payment history records, and retaining records in the same manner as IV-D cases. Enforcement services are not provided. Case records are determined confidential as per R.S. 46:56.

B. Payments must be made payable to Department of Social Services, as directed at a specific post office box which differentiates the payment from other types of Department of Social Services payments. When a payment is received from the absent parent or that parent's employer, then a new check for the same amount will be issued to the custodial parent. Payments will be distributed in accordance with the agency's non-AFDC distribution schedule. The clerks of court will provide information to identify a case if requested by the Department of Social Services.

AUTHORITY NOTE: Promulgated in accordance with 45 CFR 303.100, P.L. 100-485 and R.S. 9:303.

HISTORICAL NOTE: Promulgated by the Department of Social Services, Office of Family Support, LR 20:

§2802. Agency Guidelines

A. Information required to be provided in order for the department to properly identify and distribute payments are the names, mailing addresses, Social Security numbers, and dates of birth of both the custodial and absent parent, obligation amount, effective date of obligation, frequency of payment, docket number, child(ren)'s name(s), child(ren)'s Social Security numbers, and child(ren)'s dates of birth. Custodial parents must report changes of address to the Department of Social Services. If there is insufficient identifying information to process a payment, the department will hold payments in a suspense file until necessary information is received.

B. Whenever a posting and/or distribution error is discovered resulting in an overpayment, action will be taken to resolve the problem by asking the custodial parent to return the check to the department. Otherwise, the department will institute recoupment of the overpayment by withholding up to 10 percent from future payment(s) in the case.

C. When there are disputes regarding the handling of the immediate income assignment on a non-IV-D case, the parties may ask for an administrative review of the matter through written request to the Director, Support Enforcement Services, Box 94065, Baton Rouge, LA 70804-4065.

AUTHORITY NOTE: Promulgated in accordance with 45 CFR 303.100, P.L. 100-485 and R.S. 9:303.

HISTORICAL NOTE: Promulgated by the Department of Social Services, Office of Family Support, LR 20:

Gloria Bryant-Banks
Secretary

DECLARATION OF EMERGENCY

Department of State
Office of Uniform Commercial Code

Central Registry Master List Program (LAC 10:XIX.321)

In accordance with the emergency provisions of the Administrative Procedure Act, R.S. 49:953(B), and R.S. 49:230(C)(2), the Department of State, Office of the Uniform Commercial Code adopted the following emergency rule on December 3, 1993. The effective date of this emergency rule is January 1, 1994 and it shall remain in effect for 120 days or until the final rule takes effect through the normal promulgation process, whichever occurs first. Adoption of emergency rules at this time is necessary to amend existing rules relative to Farm Product Encumbrances. When the Central Registry Program was transferred from the Department of Agriculture to the Secretary of State all procedures and fees remained in place as adopted by the Department of Agriculture. It has now been determined that fees currently assessed do not cover the cost of the service

being provided; therefore, a serious budget deficit will again be experienced if we do not adopt this emergency rule.

(Editor's Note: LAC Title 10 has been recodified with new Part numbers; Chapter numbers within each Part remain the same.)

Title 10

FINANCIAL INSTITUTIONS, CONSUMER CREDIT, INVESTMENT SECURITIES AND UCC

Part XIX. Uniform Commercial Code

Chapter 3. Central Registry

§321. Schedules of Fees for Filing and Encumbrance

Certificates

A. - B...

C. Registration (Initial and Renewal) for the Master List of Farm Product Encumbrances shall be assessed each calendar year and are calculated as follows:

Farm Product

Category	Price Per Product	Parish(es)
I	\$20	*\$5 per parish selected
II	\$15	
III	\$10	
IV	\$ 5	

*Count each parish only once, even if a parish is chosen for more than one product.

AUTHORITY NOTE: Promulgated in accordance with R.S. 3:3655 and Public Law 99-198 (Food Security Act of 1985).

HISTORICAL NOTE: Promulgated by the Department of State, Office of Uniform Commercial Code, LR 17:496 (May 1991), amended LR 20:

Fox McKeithen
Secretary of State

DECLARATION OF EMERGENCY

Department of Treasury
Board of Trustees of the State Employees Group Benefits
Program

Plan Document

In accordance with the applicable provisions of the Administrative Procedure Act, R.S. 49:953(B), notice is hereby given that the Board of Trustees of the State Employees Group Benefits Program has adopted several changes to the Plan Document. These changes affect the eligibility and benefits sections of the Plan Document.

This emergency adoption is necessary to incorporate the changes imposed by the Board of Trustees and the changes mandated by the Legislature in the current plan document of benefits. It is necessary to finalize the benefits of the Group Benefits Program in order that the participating HMOs may comply with the provisions of Act 942 of the 1992 Regular Session. Failure to do so will affect payment of health care benefits for employees of state government and participating school boards and state political subdivisions, and the dependents of such employees, who are covered by the State Employees Group Benefits Program. This emergency rule

will go into effect on December 9, 1993 and will remain in effect for 120 days.

Copies of the amended Board of Trustees, State Employees Group Benefits Program Plan Document may be obtained from the Office of the State Register, Box 94095, Baton Rouge, LA 70804.

James R. Plaisance
Executive Director

DECLARATION OF EMERGENCY

Department of Wildlife and Fisheries Wildlife and Fisheries Commission

Commercial Fisherman's Sales Report Forms (LAC 76:VII.203)

In accordance with the emergency provisions of R.S. 49:953(B), the Administrative Procedure Act, and R.S. 56:345(B) which allows the secretary to promulgate rules and regulations on the submission of commercial fisherman's sales report forms to the department; LAC 76:VII.203.D is being amended which establishes an implementation date of July 1, 1992. The Department of Wildlife and Fisheries hereby finds that imminent peril to the public welfare exists and accordingly adopts the following emergency rule to remain in effect for 120 days.

Title 76

WILDLIFE AND FISHERIES

Part VII. Fish and Other Aquatic Life

Chapter 2. General Provision

§203. Commercial Fisherman's Sales Report Form

* * *

D. Effective immediately the full implementation date for the Commercial Fisherman's Sales Report Forms is January 1, 1995.

AUTHORITY NOTE: Promulgated in accordance with R.S. 56:345(B).

HISTORICAL NOTE: Promulgated by the Department of Wildlife and Fisheries, Wildlife and Fisheries Commission, LR 18:82 (January 1992), repromulgated LR 18:199 (February 1992), amended LR 20:

The secretary has amended the full implementation date of the Commercial Fisherman's Sales Report Forms to January 1, 1995, due to the lack of sufficient funding to initiate and maintain the program.

Joe L. Herring
Secretary

DECLARATION OF EMERGENCY

Department of Wildlife and Fisheries Wildlife and Fisheries Commission

Dealer Receipt Forms (LAC 76:VII.201)

In accordance with the emergency provisions of R.S. 49:953(B), the Administrative Procedure Act, and R.S. 56:306.4(E) which allows the secretary to promulgate rules and regulations on the submission of dealer receipt forms to the department; LAC 76:VII.201.F which establishes an implementation date of July 1, 1992 is being amended. The Department of Wildlife and Fisheries hereby finds that imminent peril to the public welfare exists and accordingly adopts the following emergency rule to remain in effect for 120 days.

Title 76

WILDLIFE AND FISHERIES COMMISSION

Part VII. Fish and Other Aquatic Life

Chapter 2. General Provision

§201. Commercial Fisherman's Sales Card; Dealer Receipt Form

* * *

F. Effective immediately, the full implementation date for the Dealer Receipt Forms is January 1, 1995.

AUTHORITY NOTE: Promulgated in accordance with R.S. 56:303.7.

HISTORICAL NOTE: Promulgated by the Department of Wildlife and Fisheries, Wildlife and Fisheries Commission, LR 18:81 (January 1992), repromulgated LR 18:198 (February 1992), amended LR 20:

The secretary has amended the full implementation date of the Dealer Receipt Forms to January 1, 1995 due to the lack of sufficient funding to initiate and maintain the program.

Joe L. Herring
Secretary

DECLARATION OF EMERGENCY

Department of Wildlife and Fisheries Wildlife and Fisheries Commission

Fall Shrimp Season Closure

In accordance with the emergency provisions of R.S. 49:953(B) and R.S. 49:967 of the Administrative Procedure Act, which allows the Wildlife and Fisheries Commission to use emergency procedures to set shrimp seasons and R.S. 56:497 which provides that the Wildlife and Fisheries Commission shall fix no less than two open seasons each year for all inside waters, the Wildlife and Fisheries Commission hereby orders that the 1993 Fall Inshore Shrimp Season shall be closed in all of the state's inshore waters at 12:01 a.m. Monday, December 20, 1993. R.S. 56:498 provides that the

minimum legal count on white shrimp is 100 (whole shrimp) count per pound after the third Monday in December. Historical and current biological sampling conducted by the Department of Wildlife and Fisheries has indicated that white shrimp in all inshore shrimp zones will not average 100 count minimum size or larger when the count is reinstated.

Bert H. Jones
Chairman

DECLARATION OF EMERGENCY

Department of Wildlife and Fisheries Wildlife and Fisheries Commission

Red Snapper Commercial Fishery Closure

In accordance with the emergency provisions of R.S. 49:953(B), the Administrative Procedure Act, R.S. 49:967 which allows the Department of Wildlife and Fisheries and the Wildlife and Fisheries Commission to use emergency procedures to set finfish seasons, and R.S. 56:317 which provides that the secretary of the department may declare a closed season when it is in the best interest of the state; the secretary of the Department of Wildlife and Fisheries hereby finds that an imminent peril to the public welfare exists and accordingly adopts the following emergency rule.

Effective 12:01 a.m. January 1, 1994, the commercial fishery for red snapper in Louisiana waters will remain closed until 12:01 a.m. February 10, 1994.

The commercial fishery for red snapper was closed by emergency action effective June 11, 1993. That action remains in effect until January 1, 1994, at which time the Gulf of Mexico Fishery Management Council was expected to reopen federal waters to the commercial harvest of red snapper. The council has since delayed the expected date for reopening federal waters until February 10, 1994. This notice is required to maintain a concurrent closure of state waters, as requested by the council. The secretary has been notified by the Gulf of Mexico Fishery Management Council and the National Marine Fisheries Service that the season closure is necessary to prevent overfishing of this species.

Joe L. Herring
Secretary

RULES

RULE

Department of Agriculture and Forestry Office of Agro-Consumer Services Division of Weights and Measures

Weights and Measures (LAC 7:XXXV.Chapter 175)

Under the authority of the Louisiana Weights and Measures Law, R.S. 3:4601 et seq., and in accordance with the provisions of the Administrative Procedure Act, R.S. 49:950 et seq., the Office of Agro-Consumer Services, Division of Weights and Measures has amended, repealed and adopted, in part, the following regulations pertaining to the enforcement of the Louisiana Weights and Measures Law. These rules comply with and are enabled by R.S. 3:4608.

Title 7

AGRICULTURE AND ANIMALS

Part XXXV. Division of Weights and Measures

Chapter 175. Division of Weights and Measures

§17501. Specifications, Tolerances and Regulation for Commercial Weighing and Measuring Devices

A. The Commissioner of Agriculture and Forestry, under authority conferred by the Louisiana Revised Statutes of 1950, Title 3, Section 4608, and for the enforcement of requirements applicable to the equipment therein referred to, hereby adopts by reference all rules, regulations, standards, specifications and tolerances as contained in the National Bureau of Standards and Technology Handbook H-44, and amendments thereto, entitled *Specifications, Tolerances, and Regulations for Commercial Weighing and Measuring Devices*, but only insofar as the Louisiana Revised Statutes of 1950, as amended, may provide.

AUTHORITY NOTE: Promulgated in accordance with R.S. 3:4606 and R.S. 3:4608 (formerly R.S. 55:4 and R.S. 55:6).

HISTORICAL NOTE: Adopted by the Department of Agriculture, Commission of Weights and Measures, April 1953, amended by the Department of Agriculture and Forestry, Office of Agro-Consumer Services, Division of Weights and Measures, LR 19: (December 1993).

§17502. Definitions

Wherever in these regulations the masculine is used, it includes the feminine and vice versa; wherever the singular is used, it includes the plural and vice versa.

Accurate—a device that when its performance or value (that is, its indications, its deliveries, its recorded representations or its capacity or actual value, etc., as determined by test made with suitable standards) conforms to the standard within the applicable tolerances and other performance requirements. Equipment that fails to conform is inaccurate.

Commercial—the use:

- a. in proving the size, quantity, extent, area or measurement of things for distribution or consumption, purchased or offered, or submitted for sale, hire or award;
- b. in computing any charge for services rendered on the basis of weight or measure; or

c. in determining weight or measure when a charge is made for the determination.

Commission—the Commission of Weights and Measures established in R.S. 3:4603.

Compound Weighing Device—a weighing device that in its operation utilizes either more than one load receiving element and/or more than one primary indicating element.

Correct—conformance to all applicable requirements for weighing and measuring devices. Any other device is incorrect.

Indicating Element—an element incorporated in a weighing or measuring device by means or which its performance relative to quantity or money value is read from the device itself (i.e. an index-and-graduated-scale combinations, a weighbeam-and-pan combination, a digital indicator, etc.).

Load-receiving Element—that component of a scale that is designed to receive the load to be weighed (i.e. platforms, decks, rails, hoppers, platters, plates, scoops, etc.).

Primary indicating element—those principal indicating elements (visual) and recording elements that are designed to, or may, be used by the operator in the normal commercial use of a device. The term "primary" is applied to any element or elements that may be the determining factor in arriving at the sale representation when the device is used commercially. (Examples of primary elements are the visual indicators for meters or scales not equipped with ticket printers or other recording elements for meters or scales so equipped.) The term "primary" is not applied to such auxiliary elements (i.e. the totalizing register of predetermined-stop mechanism on a meter or the means for producing a running record of successive weighing operations) as these elements being supplementary to those that are the determining factors in sales representations of individual deliveries or weights.

Weights, Measures, or Weighing and Measuring Devices—all weights, scales, beams, measures of every kind, instruments and mechanical devices for weighing or measuring, and any appliances and accessories connected with any such instruments.

AUTHORITY NOTE: Promulgated in accordance with R.S. 3:4603 (formerly R.S. 55:3).

HISTORICAL NOTE: Promulgated by the Department of Agriculture and Forestry, Office of Agro-Consumer Services, Commission of Weights and Measures, LR 13:157 (March 1987), amended by the Department of Agriculture and Forestry, Office of Agro-Consumer Services, Division of Weights and Measures, LR 19: (December 1993).

§17503. Commodities

A. Method of Sales, Quantity Statements

1. The offer to sell and/or the sale of all commodities shall be on the basis of net weight, net measure, or numerical count, in accordance with the following provisions; however, such provisions shall not apply to fresh vegetables which by common custom are offered for sale, and/or sold by the bunch.

2. The quantity of solids shall be stated in terms of weights and the quantity of liquids in terms of measure, except that in the case of a commodity in respect to where there exists a definite trade custom otherwise, the statement may be

in terms of weight or measure in accordance with such custom.

3. The quantity of viscous or semi-solid commodities, or of mixtures of solids and liquids may be stated either by weight or measure, but the statement shall be definite and shall indicate whether the quantity is stated in terms of weight or measure.

4. Where it is practical to state the quantity of a commodity in terms of numerical count, the employment of such statement is contingent upon the commodity being in definite units.

5. Statement of weight shall be in terms of the avoirdupois pound and ounce.

6. Statement of liquid measure shall be in the terms of the United States gallon of 231 cubic inches, and quart, pint, and fluid ounce subdivisions thereof.

7. Statement of dry measure shall be in terms of the United States standard bushel of 2150.42 cubic inches, and peck, dry quart, and dry pint subdivisions thereof.

8. Statement of linear measure shall be in terms of the standard yard, foot and inch subdivisions thereof.

9. Statements may be in terms of the metric system, anything in these regulations notwithstanding, where the commodity is customarily bought and sold by metric weight or measure.

B. General Requirements

1. When any term common to more than one system of weights or measures is employed in the quantity statement, said statement shall include the proper qualification of the term, as, for example; either *avoirdupois ounces* or *fluid ounces*; *liquid pints* or *dry pints*; *liquid quarts* or *dry quarts*.

2. In connection with the weight, measure, or numerical count, no qualifying word, phrase or clause shall be used; a statement such as *not less than*, *average*, *when packed*, or a statement that the contents are *between* certain limits, is not permissible.

3. All commodities in package form shall be in full compliance with the law; otherwise, there shall be applied thereto an appropriate violation notice or tag. Such notice or tag shall not be obliterated or removed from the package until the commodity in question shall be in compliance with the law, and approved by the commission.

C. Labeling; Container Construction; Drainage

1. All commodities in package form shall bear a printed or stenciled label containing (a) the true name of the commodity in the package, and (b) the name and place of business of the manufacturer, packer, distributor, or seller. Such label must be legible and in the English language and must not be covered or obscured in any way.

2. No container wherein commodities are packed shall have a false bottom, false side walls, false lid or covering, or otherwise so constructed or filled, wholly or partially as to facilitate the perpetration of deception or fraud.

3. A load receiving element intended for the purpose of weighing wet commodities shall be constructed as to drain effectively.

D. Package Markings; Exemptions. The following shall be exempt from the provisions of the law, requiring the net quantity marking of commodities in package form:

1. All packages of food and/or dry commodities weighing one avoirdupois ounce or less.

2. All packages of food weighing one fluid ounce or less.

AUTHORITY NOTE: Promulgated in accordance with R.S. 3:4612, R.S. 3:4613, R.S. 3:4614, R.S. 3:4602, R.S. 3:4616 and R.S. 3:4608 (formerly R.S. 55:10, R.S. 55:11, R.S.55:12, R.S. 55:14 and R.S. 55:6).

HISTORICAL NOTE: Adopted by the Department of Agriculture, Commission of Weights and Measures, April 1953, amended by the Department of Agriculture and Forestry, Office of Agro-Consumer Services, Division of Weights and Measures, LR 19: (December 1993).

§17505. Repealed

AUTHORITY NOTE: Promulgated in accordance with R.S.55:11 and R.S. 55:6.

HISTORICAL NOTE: Adopted by the Department of Agriculture, Commission of Weights and Measures, April 1953, repealed by the Department of Agriculture and Forestry, Office of Agro-Consumer Services, Division of Weights and Measures, LR 19: (December 1993).

§17507. Repealed

AUTHORITY NOTE: Promulgated in accordance with R.S. 3:4608 (formerly R.S. 55:6).

HISTORICAL NOTE: Adopted by the Department of Agriculture, Commission of Weights and Measures, April 1953, repealed by the Department of Agriculture and Forestry, Office of Agro-Consumer Services, Division of Weights and Measures, LR 19: (December 1993).

§17508. Crawfish; Live; Boiled; Peeled

A. *Crawfish*—freshwater crustaceans of the genera *Cambarus* or *Astacus* common to Louisiana.

1. Live or boiled crawfish

a. *Live Crawfish*—any crawfish which are live at the time of purchase.

b. *Boiled Crawfish*—any crawfish, still in the shell, which have been processed by boiling or steaming.

c. Live or boiled crawfish may be sold in bags or sacks.

d. The net weight of crawfish in bags or sacks must be clearly labeled in indelible ink or otherwise waterproof lettering and in accordance with all other provisions of the Louisiana Weights and Measures Law and of these regulations.

e. The labels described in LAC 7:17508.A.4 must remain on all bags or sacks of live or boiled crawfish once they leave the possession of farmer or fisherman.

f. The net weight of boiled crawfish shall be the net weight after boiling.

g. Boiled crawfish when sold for immediate consumption on the premises are exempt from this section.

B. *Peeled Crawfish*—any crawfish which have been processed to remove the shells.

1. Peeled crawfish sold washed or cleaned.

a. Peeled crawfish which have been washed or cleaned of naturally adhering fat shall be labeled "cleaned" or "washed."

b. The net weight of the washed crawfish shall be the drained weight.

2. Peeled crawfish sold with naturally adhering fat.

a. Peeled crawfish may be packaged washed.

b. Naturally adhering fat content of packages of peeled

crawfish shall not exceed 10 percent of the net weight of the crawfish in the package.

c. Testing for compliance with the fat content provisions shall be done in accordance with procedures outlined by the division.

AUTHORITY NOTE: Promulgated in accordance with R.S. 3:4608.

HISTORICAL NOTE: Promulgated by the Department of Agriculture and Forestry, Office of Agro-Consumer Services, Division of Weights and Measures, LR 19: (December 1993).

§17509. Oysters - Method of Sale

A. Oysters Unshucked

The standards used for unshucked oysters is a barrel containing three bushels, a sack containing one and one-half bushels or a one and one-half bushel wire hamper containing 3225.63 cubic inches.

B. Oysters Shucked

Oysters shucked shall only be sold by liquid measure, containing not more than 15 percent of fluids, by numerical count or by net drained weight.

AUTHORITY NOTE: Promulgated in accordance with R.S. 3:4631, R.S. 3:4613 and R.S. 3:4608 (formerly R.S. 55:72, R.S. 55:11 and R.S. 55:6).

HISTORICAL NOTE: Adopted by the Department of Agriculture, Commission of Weights and Measures, April 1953, amended April 1972, amended by the Department of Agriculture and Forestry, Office of Agro-Consumer Services, Division of Weights and Measures, LR 19: (December 1993).

§17511. Poultry; Live; Dressed; - Method of Sale

A. The offer to sell and/or the sale of all poultry (except when for immediate consumption on the premises and except when sold by count as provided for in R.S. 3:4615) shall be only on the basis of either *live weight* or *dressed and drawn weight*.

B. *Live Weight*—the net weight of poultry which is alive at time of sale, and as such, shall be classified as *live poultry*.

C. *Dressed and Drawn Weight*—the net weight of poultry after being killed, defeathered and eviscerated, and as such, shall be classified as *dressed and drawn poultry*, with only the edible parts thereof being included in the established weight.

D. *Poultry*—includes chickens, turkeys, ducks, geese, pigeons, guineas, and any other kind of domesticated bird commercially processed and sold for human consumption.

E. Live poultry shall be weighed within 30 minutes of delivery to a poultry processing facility.

F. All poultry, when placed in a container, or in any covering or wrapper, shall have its net weight plainly and conspicuously marked or labeled on the outside of the container, covering or wrapper.

AUTHORITY NOTE: Promulgated in accordance with R.S. 3:4615, R.S. 3:4613 and R.S. 3:4608 (formerly R.S. 55:13, R.S. 55:11 and R.S. 55:6).

HISTORICAL NOTE: Adopted by the Department of Agriculture, Commission of Weights and Measures, April 1953, amended by the Department of Agriculture and Forestry, Office of Agro-Consumer Services, Division of Weights and Measures, LR 19: (December 1993).

§17512. Scales for use with Purchases of Aluminum Cans

Purchases of 20 pounds or less of aluminum cans shall be weighed on scale having at least 500 divisions with a maximum weighing capacity of 60 pounds and an accuracy equivalent to Class III as defined in N.I.S.T. Handbook 44.

AUTHORITY NOTE: Promulgated in accordance with R.S. 3:4608.

HISTORICAL NOTE: Promulgated by the Department of Agriculture and Forestry, Office of Agro-Consumer Services, Division of Weights and Measures, LR 19: (December 1993).

§17513. Scales Prohibited from Use

A. The following scales shall not be used, sold or employed for commercial purposes in the weighing of any salable commodity:

1. an *overload* type of spring scale or balance, commonly known as *household* scales;
2. a scale identified as *illegal for use in trade*;
3. a scale whose physical condition facilitates the perpetration of deception and/or fraud.

B. Any type of apparatus, when found in any store, stand, business establishment, or on any vehicle from which commodities are sold or offered for sale, and in violation of the law and/or any regulation, shall be subject to immediate condemnation and confiscation.

C. It is prohibited to remove labels or other information placed on or packaged with scales sold in this state which indicate that such scales are not suitable or not intended for commercial use.

AUTHORITY NOTE: Promulgated in accordance with R.S. 3:4609 and R.S. 3:4608 (formerly R.S. 55:7 and R.S. 55:6).

HISTORICAL NOTE: Adopted by the Department of Agriculture, Commission of Weights and Measures, April 1953, amended by the Department of Agriculture and Forestry, Office of Agro-Consumer Services, Division of Weights and Measures, LR 19: (December 1993).

§17514. Bar Code Scanning Devices and Labels

A. The price of a commodity offered for retail sale which is labeled with a computerized bar code label shall be plainly displayed, either by a price marked in English on the package containing the individual commodity, or by a placard or card placed on the shelf in front of the commodity which is clearly visible and legible.

B. The price displayed on the shelf or commodity required by Subsection A of this Section shall be precisely equal to the price actually charged by the seller.

AUTHORITY NOTE: Promulgated in accordance with R.S. 3:4608.

HISTORICAL NOTE: Promulgated by the Department of Agriculture and Forestry, Office of Agro-Consumer Services, Division of Weights and Measures, LR 19: (December 1993).

§17515. Cotton Beam Scales

A. *Cotton Beam*—a steelyard especially adopted for the weighing of bales of cotton.

B. *Normal Position*—the normal balance position of the weighbeam of a beam scale shall be horizontal. A weighbeam shall not be accelerating or in neutral equilibrium under normal operating conditions but a cotton beam shall be permitted to be slightly accelerating under load.

C. *On Cotton Beams*—the value of the minimum graduation on a cotton beam shall not exceed one pound.

D. *Sealing Cotton Beam Poise*—the plug or screw used in closing the adjusting cavity in a cotton beam poise shall be securely sealed with a lead seal bearing an identification mark of the manufacturer, repairman, or other person affixing the seal, which identification mark shall be approved by and

registered with the Director of Weights and Measures.

AUTHORITY NOTE: Promulgated in accordance with R.S. 3:4602 and R.S. 3:4614 (formerly R.S. 55:14).

HISTORICAL NOTE: Adopted by the Department of Agriculture, Commission of Weights and Measures, April 1953. Promulgated by the Department of Agriculture and Forestry, Office of Agro-Consumer Services, Division of Weights and Measures, LR 19: (December 1993).

§17517. Repealed

AUTHORITY NOTE: Promulgated in accordance with R.S. 3:4608 (formerly R.S. 55:6).

HISTORICAL NOTE: Adopted by the Department of Agriculture, Commission of Weights and Measures, April 1953, repealed by the Department of Agriculture and Forestry, Office of Agro-Consumer Services, Division of Weights and Measures, LR 19: (December 1993).

§17519. Farm Bulk Milk Tank Regulations

The Division of Weights and Measures shall test the accuracy of any and all bulk milk tanks when it deems it appropriate or necessary. All installations of milk tanks shall be installed within the specifications of the Division of Weights and Measures which are outlined below:

1. All bulk milk tanks shall be installed in a rigid and level position on a reinforced concrete floor or reinforced concrete pier extending upwards from, or through concrete floor. Each foot, or leg, shall be fastened securely to floor or piers by means of a bolt or bolts and grouted around and over foot or leg with concrete to prevent tank from any movements.

2. The floor shall be not less than six inches thick of reinforced concrete. If piers are used, they shall be imbedded in ground not less than 36 inches, or three feet. The dimensions shall not be less than 16 by 16 inches wide. The same pier dimensions apply if the pier is mounted to concrete floor in a secure position to floor that complies with above floor specifications.

3. This applies to all new floor construction after July 1, 1964 and to all new installations of tanks after January 1, 1965.

AUTHORITY NOTE: Promulgated in accordance with R.S. 40:882 and R.S. 40:883.

HISTORICAL NOTE: Adopted by the Department of Agriculture, Commission of Weights and Measures, July 1964, amended by the Department of Agriculture and Forestry, Office of Agro-Consumer Services, Division of Weights and Measures, LR 19: (December 1993).

§17521. Weighmaster

A. A weighmaster license shall be required of each individual in charge of weighing commodities being bought from or sold to the public and each such individual weighing for the public when a charge is made for such weighing or when a certificate of weights is issued. Each corporation, partnership, association, proprietorship or other business entity which engages in activities which require a licensed weighmaster shall employ at least one weighmaster per shift at each place of business. Individuals weighing at retail consumer outlets and individuals weighing prepackaged commodities shall be exempt from this provision.

B. The director of the Division of Weights and Measures may issue a weighmaster license after the applicant has passed the required test of his knowledge of weighing equipment.

C. This weighmaster license would be good for one

calendar year, beginning January 1 through the month of December, or any part of the calendar year, but would have to be renewed at least 15 days before the beginning of each calendar year.

D. The director of the Division of Weights and Measures shall have the authority to revoke or cancel any weighmaster license if it is found that the weighmaster is improperly using any type of weighing device.

AUTHORITY NOTE: Promulgated in accordance with R.S. 3:4603 (formerly R.S. 55:3).

HISTORICAL NOTE: Promulgated by the Department of Agriculture and Forestry, Office of Agro-Consumer Services, Commission of Weights and Measures, LR 13:158 (March 1987), amended LR 19: (December 1993).

§17522. Metrology Laboratory Fee Structure

A. Fees for the tolerance testing of weights shall be as follows:

	Class F	Class P
1. Weights up to and including 10 pounds or 5 kilograms	\$ 2.00	\$ 4.00
2. Weights over 10 pounds or 5 kilograms and including 100 pounds or 60 kilograms	5.00	10.00
3. Weights over 100 pounds or 60 kilograms and including 1000 pounds or 500 kilograms	25.00	50.00
4. Weights over 1000 pounds or 500 kilograms	50.00	75.00

B. Fees for mass calibration with Report of Calibration stating corrections and uncertainties shall be as follows:

1. Weights up to and including 3 kilograms or 5 pounds	\$25.00
2. Weights over 3 kilograms or 5 pounds and including 30 kilograms or 50 pounds	50.00

C. All tape certification, volumetric testing and calibration or special tests not listed in the fee schedule shall be performed at a rate of \$30 per hour.

D. Incurred costs for return shipment shall be assessed when applicable.

AUTHORITY NOTE: Promulgated in accordance with R.S. 3:4608.

HISTORICAL NOTE: Promulgated by the Department of Agriculture and Forestry, Office of Agro-Consumer Services, Division of Weights and Measures, LR 19: (December 1993).

§17523. Registration

A. Each commercial weighing and measuring device in use in Louisiana shall be registered annually with the division insofar as is specified in this regulation.

B. Whenever there shall exist a weight or measure or weighing or measuring device in or about any place in which or from which buying or selling is commonly carried on, there shall be a rebuttable presumption that such weight or measure or weighing or measuring device is regularly used for the business purposes of that place and shall be registered as a commercial device.

C. Scales shall be registered according to the following criteria:

1. make;
2. model;
3. serial number;
4. capacity; and
5. intended use.

D. A late fee of \$25 will be assessed for each device, the maximum penalty of \$100 per outlet, when the application is submitted after December 31.

E. A late fee of \$25 will be assessed for each new device not registered within 30 days from the date it is put into service.

F. A compound weighing device shall be considered one or more devices for the purpose of registration in accordance with the following:

1. A compound weighing device that consists of a single load receiving element and more than one indicating element shall be considered a single device when all indicating elements may be tested during the same test for the purpose of sealing the device as correct. Said device shall be considered separate devices for each separate test necessary for sealing.

2. A compound weighing device that consists of one indicating element and more than one load receiving element shall for the purpose of registration be considered a separate device for each load receiving element.

G. Applicants for registration may request application forms, verbally or in writing, from the Division of Weights and Measures of the Department of Agriculture and Forestry.

H. Each application for annual registration shall be accompanied by payment of required fee and said registration shall be valid until December 31. To remain valid, each annual registration must be renewed on or before January 1.

I. Any registration obtained without complying with all of the requirements of these regulations may be voided by the division.

J. Before a device may be sealed to certify the accuracy and correctness of a device, that device must be registered with the Division of Weights and Measures of the Louisiana Department of Agriculture and Forestry.

K. In accordance with R.S.3:4611, no one shall use a weight, measure or weighing or measuring device which has not been sealed by the division, its director, or its inspectors, at its direction, within the year prior thereto, unless written notice has been given to the division to the effect that the weight, measure or weighing or measuring device is available for examination or is due for re-examination.

L. Application for registration or renewal of registration shall fulfill the requirement of notification in Subsection K of this Section.

M. Applications for annual renewal of registration shall be mailed by the Division of Weights and Measures of the

Department of Agriculture and Forestry to all registrants, at the last address provided by the registrant, on or before November 15 and must be returned on or before January 1.

N. The record of all registrations shall be maintained by the Division of Weights and Measures and the director of the Division of Weights and Measures in its office in Baton Rouge.

O. Any registrant having a device registered under provisions of this regulation, and that is taken out of commercial use at the location shown on the application for registration, shall notify the commission's office in writing to remove said device from its records.

Note: This regulation shall expire 12 years from the date of adoption. The fee shall only be used to pay for the direct and indirect costs of the weights and measures program and are anticipated to generate \$456,304 annually in revenues. The kinds and anticipated amounts of costs, which will be offset by this, include, but are not limited to: Personal Services - \$331,489; Operating Expenses - \$110,632. The Department of Agriculture and Forestry shall suspend collection upon finding by the Department of Agriculture and Forestry that collections will exceed the cost of the program.

AUTHORITY NOTE: Promulgated in accordance with R.S. 3:4603 (formerly R.S. 55:3).

HISTORICAL NOTE: Promulgated by the Department of Agriculture and Forestry, Office of Agro-Consumer Services, Commission of Weights and Measures, LR 13:158 (March 1987) amended LR 15:78 (February 1989), amended by the Department of Agriculture and Forestry, Office of Agro-Consumer Services, Division of Weights and Measures, LR 19: (December 1993).

§17525. Standards

A. For the purposes of registration of weighing and measuring devices, the criteria shall be compliance with the applicable requirements of NIST Handbook 44 "Specifications, Tolerances, and Other Technical Requirements for Weighing and Measuring Devices." This publication is published annually by the United States Department of Commerce, National Institute of Standards and Technology.

B. For any device being registered for the first time, it shall be determined that the above criteria has been met and that the device:

1. has been tested and approved in Louisiana prior to January 1, 1987, with no modifications to the device since such test and approval;

2. has been tested by the National Bureau of Standards and shown to comply with Handbook 44 criteria by the issuance of a Report of Test (Prior to 1985) or a Certificate of Conformance (1985, Forward); or

3. has been tested by the Division of Weights and Measures of the Louisiana Department of Agriculture and Forestry or another state which uses Handbook 44 as its criteria and has been issued a certificate stating such test and compliance with said criteria.

C. For the purpose of registration of a weighing and measuring device, the stated intended use shall be a use that the manufacturer intended or a use that is proven suitable for that device.

AUTHORITY NOTE: Promulgated in accordance with R.S. 3:4603 (formerly R.S. 55:3).

HISTORICAL NOTE: Promulgated by the Department of Agriculture and Forestry, Office of Agro-Consumer Services, Commission of Weights and Measures, LR 13:158 (March 1987), amended by the Department of Agriculture and Forestry, Office of

Agro-Consumer Services, Division of Weights and Measures, LR 19: (December 1993).

§17527. Penalties

A. The commission, or his duly authorized representative, shall mark any device that is incorrect and warn its owner or user that the device is incorrect and should not be used until it is made correct. If a device that has been so marked as incorrect continues to be used commercially, the commission may seize the device in order to protect the public. The commission shall give a notice of intent to seize the incorrect device five calendar days before the actual seizure. However, a device which is not used at fixed location may be seized immediately upon a determination that said device is incorrect.

B. Upon a showing by the owner or user that adequate steps have been taken to correct the seized device, the commission shall release the seized device.

C. The commission shall give the owner or user of the seized device a hearing within 60 calendar days of a request for such a hearing. If the owner or user of the seized device fails to request a hearing on the seizure within 30 days of seizure, the right to a hearing shall be deemed waived.

D. If the owner or user waives his right to request a hearing and takes no action to retrieve the device within 60 days of seizure, the device shall be deemed abandoned property. The device may then be disposed of by the state with an obligation to the owner.

AUTHORITY NOTE: Promulgated in accordance with R.S. 3:4603 (formerly R.S. 55:3).

HISTORICAL NOTE: Promulgated by the Department of Agriculture and Forestry, Office of Agro-Consumer Services, Commission of Weights and Measures, LR 13:158 (March 1987), repromulgated, LR 19: (December 1993).

§17529. Powers of the Director

When necessary for the enforcement of the Louisiana Weights and Measures Law or any rule adopted pursuant thereto, the director or an employee at his direction may:

1. stop any commercial vehicle from which commodities are kept for sale, sold or in the process of delivery on the basis of weight measure or count and, after presentment of his credentials, inspect the contents, require that the person in charge of that vehicle produce any documents in his or her possession concerning the contents, and require him to proceed with the vehicle to a specified place for inspection; and

2. Access all books, papers and other information necessary for the enforcement of the Louisiana Weights and Measures Law. If after inspection the director finds or has reason to believe that the requirements set forth in the Louisiana Weights and Measures Law are not being met, he shall have access to all books, papers, records, bills of lading, invoices and other pertinent data relating to the use, sale or representation of any commodity including weighing and measuring devices within this state.

AUTHORITY NOTE: Promulgated in accordance with R.S. 3:4608 and R.S. 3:4607.

HISTORICAL NOTE: Promulgated by the Department of Agriculture and Forestry, Office of Agro-Consumer Services, Division of Weights and Measures, LR 19: (December 1993).

Bob Odom
Commissioner

RULE

**Department of Culture, Recreation and Tourism
Office of Cultural Development
Division of the Arts**

**Mission and Grant Applicant Information
(LAC 25:I.Chapter 3)**

The Department of Culture, Recreation and Tourism, Office of Cultural Development, Division of the Arts hereby amends LAC 25:I.Chapter 3.

Title 25

CULTURAL RESOURCES

Part I. Office of Cultural Development

Chapter 3. Division of the Arts

§301. Introduction: Arts Programs in Louisiana

A. - E. ...

1. The council and division have established advisory panels to assist in administering arts grant programs. Panelists are experienced artists, arts administrators, and other professionals knowledgeable in the arts, and are recommended by individuals, organizations, and division staff. The council approves panelists selected by the division to represent all geographic areas and differing aesthetic and cultural perspectives. Appointments are for one year and may be extended to no more than three consecutive years. Contact the division for instructions on nominating panelists.

E.2. ...

AUTHORITY NOTE: Promulgated in accordance with R.S. 25:894 and 25:896.

HISTORICAL NOTE: Promulgated by the Department of Culture, Recreation and Tourism, Office of Cultural Development, Division of the Arts, LR 7:625 (December 1981), amended LR 8:510 (October 1982), LR 9:684 (October 1983), LR 11:341 (April 1985), LR 11:1137 (December 1985), LR 13:740 (December 1987), LR 14: 845 (December 1988), LR 15:720 (September 1989), LR 17:1202 (December 1991), LR 18:1115 (October 1992), LR 19: (December 1993).

§303. Eligibility and Administration

Repealed.

§305. Guidelines for Applications

A. 1. All applications must be postmarked by March 1. The division will not assume responsibility for lost or misdirected mail. Late applications will be ineligible.

2. Applications will be accepted only for arts activities scheduled to begin no earlier than July 1 and end no later than June 30 of the fiscal year for which the application is submitted.

3. Requests for grants must be submitted on current grant application forms, which may not be altered in any way.

4. Application forms are available from your local arts agency or the Division of the Arts from December 1 to March 1.

5. The guidelines on how grants are to be applied for and awarded will be reviewed yearly. The public is encouraged to provide input during the month of June to be considered for the next year's guidelines.

AUTHORITY NOTE: Promulgated in accordance with R.S. 25:894 and 25:896.

HISTORICAL NOTE: Promulgated by the Department of Culture, Recreation and Tourism, Office of Cultural Development, Division of the Arts, LR 7:625 (December 1981), amended LR 8:510 (October 1982), LR 9:684 (October 1983), LR 11:341 (April 1985), LR 11:1137 (December 1985), LR 13:740 (December 1987), LR 14: 845 (December 1988), LR 15:720 (September 1989), LR 17:1202 (December 1991), LR 18:1115 (October 1992), LR 19: (December 1993).

§307. Individual Artist Programs

Repealed.

§309. Documentation and Samples of Work

Repealed.

§311. Compliance with Administrative Regulations

Repealed.

§313. Glossary

Repealed.

Gerri Hobdy
Assistant Secretary

RULE

**Department of Culture, Recreation and Tourism
Office of State Parks**

Overnight and Day Use (LAC 25:IX.505)

(Editor's Note: A portion of the following Section, which ran on pages 311-313 of the March, 1993 Louisiana Register, is being republished to include information which was inadvertently omitted in §505.B. The rule which ran in March, 1993, corrected all references to "historic site" to "commemorative area." References in §505.H.5.c and §505.H.6.c are being republished to include this amendment.)

Title 25

CULTURAL RESOURCES

Part IX. Office of State Parks

Chapter 5. Procedures and Fees

§505. Overnight and Day Use Fee

A.1-3...

B. Rally Camping Areas are those areas of a Louisiana state park designated and reserved for use by organized groups of overnight campers. These areas differ from the normal state park campgrounds since they are available for group use and may be reserved in advance.

1-3...

C-H.5.a-b...

c. After arriving at Poverty Point SCA, the user is required to pay all rental fees to the commemorative area manager before occupying the dormitory.

d...

6.a...

b. Keys to the dormitory can be obtained from the commemorative area manager. One group leader will assume responsibility for the keys and return them to the manager before leaving.

c...

7-14...

AUTHORITY NOTE: Promulgated in accordance with R.S. 56:1681-1693.

HISTORICAL NOTE: Promulgated by the Department of Culture, Recreation and Tourism, Office of State Parks, LR 8:633 (December 1982), amended LR 11:251 (March 1985), LR 12:89 (February 1986), LR 12:828 (December 1986), LR 14:775 (November 1988), LR 16:1053 (December 1990), LR 19:311 (March 1993), repromulgated LR 19: (December 1993).

Jim Ball
Assistant Secretary

RULE

Department of Economic Development Board of Examiners of Certified Shorthand Reporters

Certification, Examinations, Continuing Education, Hearings and Fees (LAC 46: XXI.Chapters 1 - 9)

The Department of Economic Development, Board of Examiners of Certified Shorthand Reporters has amended LAC 46: XXI.Chapters 1 through 9, as follows:

Title 46

PROFESSIONAL AND OCCUPATIONAL STANDARDS

Part XXI. Certified Shorthand Reporters

Chapter 1. Certification

§101. Application for Certification

An applicant for a certificate shall file an application on a form provided by the board (Board of Examiners of Certified Shorthand Reporters), accompanied by any applicable fees, and such evidence, statements or documents required by said form. If an examination is required, said application must be filed with the board at least 30 days prior to an examination date. A new application is required for each examination.

AUTHORITY NOTE: Promulgated in accordance with R.S. 37:2554.

HISTORICAL NOTE: Promulgated by the Department of Commerce, Board of Examiners of Certified Shorthand Reporters, LR 9:678 (October 1983), amended by the Department of Economic Development, Board of Examiners of Certified Shorthand Reporters, LR 14:530 (August 1988), LR 16:393 (May 1990), LR 19: (December 1993).

§103. Qualifications for Certification

A. Any person over the age of 18 years, who has not committed any acts, crimes, or omissions constituting grounds for suspension or revocation of a certificate issued by the board pursuant to R.S. 37:2557(A), who has a high school education or its equivalent as determined by the board, and who has satisfactorily passed each portion of the examination described in Chapter 3 of these rules, in accordance with the rules of the board, shall be entitled to a certified court reporter certificate.

B. Effective January 1, 1994, the board shall convert all licenses held by a certified shorthand reporter or certified general reporter to that of a certified court reporter. Thereafter, any person who on December 31, 1993, held a license in good standing as a certified shorthand

reporter or certified general reporter may apply to the board for issuance of a license as a certified court reporter, subject to the payment of all applicable renewal fees, satisfaction of continuing education requirements, and compliance with other conditions imposed by the board.

AUTHORITY NOTE: Promulgated in accordance with R.S. 37:2554 and 37:2557(A).

HISTORICAL NOTE: Promulgated by the Department of Commerce, Board of Examiners of Certified Shorthand Reporters, LR 9:678 (October 1983), amended by the Department of Economic Development, Board of Examiners of Certified Shorthand Reporters, LR 17:31 (January 1991), LR 19: (December 1993).

Chapter 3. Examinations

§301. Applications for Examinations

* * *

C. Applicant must furnish a diploma, official transcript or certificate from a licensed court reporting school that he has passed a qualifying test consisting of five minutes of two-voice Q & A at 225 wpm with 95 percent accuracy within one year prior to application to the board for examination; or a CSR certificate from another state issued with a minimum requirement of 225 wpm; or participate in an equivalent qualifying test administered by the board on a date designated by the board.

An application fee of \$25 shall be paid to the board by the applicant participating in a qualifying test administered by the board, which fee shall be refundable to the applicant upon completion of the qualifying test. An applicant who fails to timely appear for the qualifying examination by the board shall be deemed to have abandoned the application and shall forfeit the application fee for said qualifying test. Proof of passing said qualifying test must accompany the application for examination.

D. Applicants who have been found to be qualified for the examination shall be notified in writing of the time and place of their assigned examination.

E. An applicant who fails to timely appear for examination after being notified of eligibility shall be deemed to have abandoned the application and shall forfeit the application fee. In order again to become eligible for an examination, such person shall file a new application and otherwise comply in all respects with the provisions of the act and these regulations in the same manner as required of an original applicant.

F. An applicant who commences but does not finish the examination or who otherwise fails such examination shall not be eligible for any future examination except upon filing a new application and otherwise complying in all respects with the provisions of the act and these regulations in the same manner as required of the original applicant.

AUTHORITY NOTE: Promulgated in accordance with R.S. 37:2554.

HISTORICAL NOTE: Promulgated by the Department of Commerce, Board of Examiners of Certified Shorthand Reporters, LR 9:678 (October 1983), amended by the Department of Economic Development, Board of Examiners of Certified Shorthand Reporters, LR 14:530 (August 1988), LR 16:393 (May 1990), LR 17:578 (June 1991), LR 19: (December 1993).

§309. Grading of Examination

* * *

F. For the purpose of grading stenotype tests, errors will be assessed in accordance with the guidelines accepted by the National Shorthand Reporters Association. For the purpose of grading stenomask tests, errors will be assessed in accordance with guidelines accepted by the National Stenomask Verbatim Reporters association.

AUTHORITY NOTE: Promulgated in accordance with R.S. 37:2554.

HISTORICAL NOTE: Promulgated by the Department of Commerce, Board of Examiners of Certified Shorthand Reporters, LR 9:678 (October 1983), amended by the Department of Economic Development, Board of Examiners of Certified Shorthand Reporters, LR 14:530 (August 1988), LR 16:393 (May 1990), LR 17:578 (June 1991), LR:19:1010 (August 1993), LR 19: (December 1993).

§311. Review of Examinations

Examinees will have a period of 90 days from the release of the test results to review examinations in the offices of the board. Written notification of an examinee's intent to review the examination must be received at the board's office five days prior to the review of the examination. Examinations may be reviewed only during normal working hours. On request in writing from an applicant, the board may release to applicant a copy of applicant's transcribed portion of the skills test upon payment by applicant of \$.25 per page for said copy.

AUTHORITY NOTE: Promulgated in accordance with R.S. 37:2554.

HISTORICAL NOTE: Promulgated by the Department of Commerce, Board of Examiners of Certified Shorthand Reporters, LR 9:678 (October 1983), amended by the Department of Economic Development, Board of Examiners of Certified Shorthand Reporters, LR 14:530 (August 1988), LR 19: (December 1993).

§313. Failure of Examination

* * *

D. Request for Hearing

If the applicant is not satisfied with the results of the review committee's action, the applicant may request a hearing before the board. Such request for hearing shall be in writing and shall be filed with the board within 10 days after receipt of notice of the review committee's action from the board.

E. Hearing Procedures

The rules set forth in Chapter 7 hereof shall govern appeals taken by an applicant who fails an examination.

AUTHORITY NOTE: Promulgated in accordance with R.S. 37:2554.

HISTORICAL NOTE: Promulgated by the Department of Commerce, Board of Examiners of Certified Shorthand Reporters, LR 9:678 (October 1983) amended by the Department of Economic Development, Board of Examiners of Certified Shorthand Reporters, LR 19: (December 1993).

Chapter 5. Certificates

§501. Expiration of Certificate

All certificates shall be suspended as of 12 p.m. on December 31 of each year if not, in each instance, renewed. To renew a certificate, the certificate holder shall, on or before the date on which the certificate would otherwise be suspended, pay the renewal fee established by the board. A suspension under this Section shall be effective until all delinquent fees have been paid in full.

AUTHORITY NOTE: Promulgated in accordance with R.S. 37:2554.

HISTORICAL NOTE: Promulgated by the Department of

Commerce, Board of Examiners of Certified Shorthand Reporters, LR 9:678 (October 1983), amended by the Department of Economic Development, Board of Examiners of Certified Shorthand Reporters, LR 14:530 (August 1988), LR 19: (December 1993).

§503. Certificate Number

A reporter shall indicate the reporter's certificate number in the certification on each transcript prepared by the reporter and shall attest that the certificate number is in good standing.

AUTHORITY NOTE: Promulgated in accordance with R.S. 37:2554.

HISTORICAL NOTE: Promulgated by the Department of Commerce, Board of Examiners of Certified Shorthand Reporters, LR 9:678 (October 1983), amended by the Department of Economic Development, Board of Examiners of Certified Shorthand Reporters, LR 14:531 (August 1988), repealed LR 17:31 (January 1991), promulgated LR 19: (December 1993).

§505. Cause for Suspension, Revocation, or Non-Issuance of Certificate

* * *

E. failure to restrict the practice of court reporting to the system under which a certificate holder is certified.

F. failure to comply with regulations promulgated by the board pursuant to the Administrative Procedure Act.

AUTHORITY NOTE: Promulgated in accordance with R.S. 37:2557.

HISTORICAL NOTE: Promulgated by the Department of Commerce, Board of Examiners of Certified Shorthand Reporters, LR 9:679 (October 1983), amended by the Department of Economic Development, Board of Examiners of Certified Shorthand Reporters, LR 17:32 (January 1991), LR 19: (December 1993).

§506. Certification Without Examination

Repealed.

AUTHORITY NOTE: Promulgated in accordance with R.S. 37:2554.

HISTORICAL NOTE: Promulgated by the Department of Economic Development, Board of Examiners of Certified Shorthand Reporters, LR 17:31 (January 1991), repealed LR 19: (December 1993).

§507. Inactive Status

A. A licensed reporter may, upon proper application and satisfactory proof, attain inactive status. A reporter on inactive status is prohibited from engaging in the practice of court reporting in Louisiana. A reporter on inactive status is not required to pay the annual renewal fee or to obtain continuing education credits.

B. The board will consider as due proof of eligibility for inactive status any of the following:

1. an affidavit signed by the applicant and stating that the applicant has not taken or transcribed depositions, investigations, conventions, hearings, court proceedings, or other such matters within the state of Louisiana as a court reporter for a period of two or more years.

2. an affidavit signed by the applicant or by the applicant's physician stating that due to medical reasons the applicant will be unable to practice as a court reporter for a period of two or more years in the future. The board may request and the applicant must afford any medical records necessary to verify the representations of medical incapacity.

3. an affidavit signed by the applicant stating that the applicant will be absent from the state of Louisiana for a period of two or more years in the future. The board may

request and the applicant must afford any requested proof of relocation (e.g., voter registration card) to verify the representations contained in the affidavit.

C. A reporter may reactivate the license that prevailed before attaining inactive status by making application to the board accompanied by payment of all fees in effect at that time for other similarly situated reporters engaged in active practice during the current calendar year. In deciding whether to permit the return to active status, the board shall consider the duration of the applicant's inactive status, the applicant's current medical condition, the applicant's current capability to perform proficiently the tasks required of a reporter, any continuing education credits obtained or any practice of shorthand reporting conducted in another state during the period while on inactive status, and such other matters as the board may deem appropriate. In making its evaluation of an applicant's request for a return to active status, the board may require copies of the applicant's medical records, may require the applicant to take a proficiency test, or may request such other information as it deems appropriate.

AUTHORITY NOTE: Promulgated in accordance with R.S. 37:2554.

HISTORICAL NOTE: Promulgated by the Department of Economic Development, Board of Examiners of Certified Shorthand Reporters, LR 19: (December 1993).

§509. Notice of Suspended, Revoked, or Inactive Certificates

Twice a year the board will issue to all court reporters, court reporting agencies, bar associations, and courts within the state of Louisiana a public notice identifying all reporters who within the preceding six months have had certificates suspended, revoked, or placed on inactive status.

AUTHORITY NOTE: Promulgated in accordance with R.S. 37:2554.

HISTORICAL NOTE: Promulgated by the Department of Economic Development, Board of Examiners of Certified Shorthand Reporters, LR 19: (December 1993).

Chapter 6. Continuing Education

§607. Maintenance of Record

* * *

E. Repealed.

AUTHORITY NOTE: Promulgated in accordance with R.S. 37:2554.

HISTORICAL NOTE: Promulgated by the Department of Economic Development, Board of Examiners of Certified Shorthand Reporters, LR 17:33 (January 1991), amended LR 17:578 (June 1991), LR 19: (December 1993).

§609. Continuing Education Guidelines

A. The following general subject matter and enumerated continuing education credits may be approved by the board in the event the subject matter contributes to the professional competence of the practitioner of court reporting:

1. Seminars and workshops sponsored by or at National Court Reporters Association (NCRA) regional, state, or local meetings, public institutions of higher learning, and judicial organization, including the following subjects:

- a. English;
- b. medical;
- c. legal;
- d. technical subjects presented by experts dealing with

terminology and concepts encountered by the reporter during depositions and at trials;

- e. new developments and knowledge in the field directly related to making the record;
- f. general court and deposition procedures;
- g. general court and deposition transcript preparation;
- h. management;
- i. professionalism; or
- j. office procedures, record-keeping, health, and the "consummate" person.

2. Formal courses sponsored by or instituted for universities and colleges, postgraduate courses held by court reporting schools, duly licensed by the state, adult education schools, duly licensed by the state, and related organizations, established and approved by the appropriate educational authority, to administer continuing education courses, subject to the approval of the Board of the Academy of Professional Reporters with formal enrollment and recordation by official transcript of the completion of the courts, including:

a. Universities and Colleges

i. A reporter who has formally enrolled in an accredited university or college and has successfully completed an academic or technical subject and received a passing grade of C or better shall receive the following credits:

- (a). one semester credit - four C.E. credits;
- (b). one trimester credit - three C.E. credits;
- (c). one quarter credit - two C.E. credits.

ii. A reporter who has formally enrolled in an academic or technical subject at an accredited university or college shall receive the following credits:

- (a). one semester credit - two C.E. credits;
- (b). one trimester credit - one C.E. credit;
- (c). one quarter credit - one C.E. credit;

b. Postgraduate Courses in Court Reporting Schools-A reporter who successfully completes a postgraduate course (excluding dictation practice) in an accredited court reporting school and receives a passing grade shall receive two C.E. credits for every postgraduate course completed.

c. Adult Education School-A reporter who successfully completes an adult education course in an academic subject at an accredited school shall receive one C.E. credit for every two contact hours.

d. The board may recognize credits from other institutions and organizations giving continuing education courses if the course concerns subject matter that meets the needs of the reporter's professional or career goals in shorthand reporting.

3. Special activities including a certificate of merit test or speed contest administered by the National Court Reporters Association (NCRA) or a board-sponsored speed contest or award of excellence, with the award of excellence credit limited to no more than one continuing education credit per reporting period, as follows:

a. Certificate of Merit Test

i. An NCRA-tested Registered Professional Reporter (RPR) passing any one section of the Certificate of Merit Test for the first time shall receive five C.E. credits.

ii. A state-tested Certified Court Reporter (C.C.R.) holding RPR status passing all three parts of the skills section

at the same time shall receive five C.E. credits for each part.

b. NCRA Speed Contest. A reporter qualifying on any one section of the NCRA Speed Contest shall receive five C.E. credits.

c. State-Sponsored Speed Contest or Award of Excellence. A reporter qualifying on any one section of state-sponsored speed contest or an Award of Excellence shall receive the following credits, provided such section equals or exceeds the requirements of the NCRA Certificate of Merit Exam:

- i. State-sponsored speed contest - four credits;
- ii. Award of Excellence - four credits.

AUTHORITY NOTE: Promulgated in accordance with R.S. 37:2554.

HISTORICAL NOTE: Promulgated by the Department of Economic Development, Board of Examiners of Certified Shorthand Reporters, LR 17:33 (January 1991), amended LR 19: (December 1993).

Chapter 7. Hearings

§701. Accused Person

The board may upon its own motion and shall upon the verified complaint in writing of any person setting forth facts which if proven would constitute grounds for refusal, suspension or revocation of a certificate, investigate the actions of any person who applies for, holds or represents that he holds a certificate. Such person is hereinafter called the accused.

AUTHORITY NOTE: Promulgated in accordance with R.S. 37:2557.

HISTORICAL NOTE: Promulgated by the Department of Commerce, Board of Examiners of Certified Shorthand Reporters, LR 9:679 (October 1983), amended by the Department of Economic Development, Board of Examiners of Certified Shorthand Reporters, LR 19: (December 1993).

§703. Written Notification

Before refusing to issue, suspending or revoking any certificate, the board shall at least 10 days prior to date set for the hearing, notify in writing the accused of any charges made and shall afford such accused person an opportunity to be heard in person or by counsel in reference thereto. Such written notice may be served by delivery of the same personally to the accused person, or by mailing the same by registered or certified mail to the address last theretofore specified by the accused person in his last notification to the board. At the time and place fixed in the notice, the board shall proceed to hearing of the charges and both the accused person and the complainant shall be accorded ample opportunity to present in person, or by counsel, such statements, testimony, evidence and argument as may be pertinent to the charges or to any defense thereto. The board may continue such hearing from time to time. If the board shall not be sitting at the time and place fixed in the notice or at the time and place at which the hearing shall have been continued, the board shall continue such hearing for a period not to exceed 30 days.

AUTHORITY NOTE: Promulgated in accordance with R.S. 37:2557.

HISTORICAL NOTE: Promulgated by the Department of Commerce, Board of Examiners of Certified Shorthand Reporters, LR 9:679 (October 1983), amended by the Department of Economic

Development, Board of Examiners of Certified Shorthand Reporters, LR 19: (December 1993).

§709. Record of Proceedings

The board, at its expense, shall provide a reporter to take down the testimony and preserve a record of all proceedings at the hearing of any case wherein a certificate may be revoked or suspended. The notice of hearing, complaint and all other documents in the nature of pleadings and written motion filed in the proceedings, the transcript of testimony, the report of the board and the orders of the board shall be the record of such proceedings. The board shall furnish a transcript of such record to any person interested in such hearing upon payment therefor of \$3 per page for each original transcript and \$1.50 per page for each carbon copy thereof ordered with the original.

AUTHORITY NOTE: Promulgated in accordance with R.S. 37:2557.

HISTORICAL NOTE: Promulgated by the Department of Commerce, Board of Examiners of Certified Shorthand Reporters, LR 9:679 (October 1983), amended by the Department of Economic Development, Board of Examiners of Certified Shorthand Reporters, LR 19: (December 1993).

§711. Report of Findings and Recommendations

The board shall present to the chairman its written report of its findings and recommendations, and the chairman shall have the right to take the action recommended by the board. Upon the suspension or revocation of a certificate, certificate holder shall be required to surrender the certificate and seal to the board, and upon the failure or refusal to do so, the board shall have the right to seize the same. A copy of such report shall be served upon the accused person and the complainant, either personally or by registered or certified mail.

AUTHORITY NOTE: Promulgated in accordance with R.S. 37:2557.

HISTORICAL NOTE: Promulgated by the Department of Commerce, Board of Examiners of Certified Shorthand Reporters, LR 9:679 (October 1983), amended by the Department of Economic Development, Board of Examiners of Certified Shorthand Reporters, LR 19: (December 1993).

§713. Appeal

An appeal of the decision of the board must be filed with a court of competent jurisdiction within 30 days from notice of suspension, revocation, or refusal.

AUTHORITY NOTE: Promulgated in accordance with R.S. 37:2557.

HISTORICAL NOTE: Promulgated by the Department of Commerce, Board of Examiners of Certified Shorthand Reporters, LR 9:679 (October 1983), amended by the Department of Economic Development, Board of Examiners of Certified Shorthand Reporters, LR 19: (December 1993).

§715. Expiration of Appeal Time

Repealed.

AUTHORITY NOTE: Promulgated in accordance with R.S. 37:2557.

HISTORICAL NOTE: Promulgated by the Department of Commerce, Board of Examiners of Certified Shorthand Reporters, LR 9:679 (October 1983), repealed by the Department of Economic Development, Board of Examiners of Certified Shorthand Reporters, LR 19: (December 1993).

Chapter 9. Fees

§901. Fees

The following fees shall be paid to the board:

1. The fee to be paid for the issuance of a certificate of registration without board examination is \$75.

2. The fee to be paid for the purchase of a list of labels that include names and addresses of current reporters for seminars shall be \$40.

3. The fee to be paid upon the renewal of the certificate of registration is \$75.

4. The fee to be paid for the purchase of a list of names and addresses of current reporters shall be \$25.

5. The fee to be paid for the reinstatement of a certificate shall be the payment of all delinquent fees, plus \$15.

6. The fee to be paid for regrading an examination shall be \$30.

7. The fee to be paid for a C.C.R. seal is \$30.

8. The fee to be paid for the purchase of examination materials is \$.25 per page and \$10 per cassette.

9. The fee to be paid for the qualifying test of Q & A at 225 wpm shall be \$25, which fee shall be refundable upon completion of the qualifying test, or forfeited should the applicant fail to appear for the taking of said qualifying test.

10. The fee to be paid for an NSF check issued to the board shall be \$15.

AUTHORITY NOTE: Promulgated in accordance with R.S. 37:2554.

HISTORICAL NOTE: Promulgated by the Department of Commerce, Board of Examiners of Certified Shorthand Reporters, LR 9:679 (October 1983), amended LR 10:269 (April 1984), amended by the Department of Economic Development, Board of Examiners of Certified Shorthand Reporters, LR 17:34 (January 1991), LR 17:578 (June 1991), LR 19: (December 1993).

Leon A. Cannizzaro, Jr.
Chairman

RULE

Department of Economic Development Office of Commerce and Industry Division of Financial Incentives

Biomedical Research and Development Park Program (LAC 13:I.Chapter 41)

The Department of Economic Development, Office of Commerce and Industry, is adopting the following rule to implement Act 990 of the 1992 Regular Session of the Louisiana Legislature.

Title 13

ECONOMIC DEVELOPMENT

Part I. Commerce and Industry

Subpart 3. Financial Incentives

Chapter 41. Louisiana Biomedical Research and Development Park Program

§4101. General

Relief from taxation may be granted as provided under R.S. 46:318.1(E).

AUTHORITY NOTE: Promulgated in accordance with R.S. 46:811 et seq.

HISTORICAL NOTE: Promulgated by the Department of Economic Development, Office of Commerce and Industry, Division of Financial Incentives, LR 19: (December 1993).

§4103. Definitions

For purposes of these rules, the following terms shall have the meaning hereafter ascribed to them, unless the context clearly indicates otherwise:

Medical Concerns which are *technology-based* or *innovative growth oriented* are defined as companies engaged in the application of science especially to industrial or commercial objectives. Such companies should be engaged in the development, manufacture, and sale of products that emerge from or depend upon the practical application of scientific or technological advances.

AUTHORITY NOTE: Promulgated in accordance with R.S. 46:811 et seq.

HISTORICAL NOTE: Promulgated by the Department of Economic Development, Office of Commerce and Industry, Division of Financial Incentives, LR 19: (December 1993).

§4105. Qualifications

To qualify for the Louisiana Biomedical Research and Development Park Program tax incentives an applicant must be a "medical concern", as defined in this rule, must provide documentation evidencing its location in the park area, as described in R.S. 46:813.A, and must demonstrate, by written statement, its viability and ability to contribute to the improved health care of citizens and through improved economic conditions, creation of jobs and to the development of the park area. The statement should include all factors which are relevant to the continued and expanded operations of the applicant including, but not limited to, the following:

1. the benefits to the state in terms of continued employment opportunities, expenditures for goods and services, contributions to the revenue base of the state and local governments, and the creation of new and additional permanent jobs;
2. competitive conditions existing in other states or in foreign nations;
3. the economic viability of the applicant, and the effect of any tax exemptions or credits on economic viability;
4. the effects on the applicant of temporary supply and demand conditions;
5. the effect of casualties and/or natural disasters;
6. the effects of United States and foreign trade policies;
7. the effect of federal laws and regulations bearing on the economic viability within the state of the applicant;
8. the competitive effect of like or similar exemptions or credits granted to other applicants.

AUTHORITY NOTE: Promulgated in accordance with R.S. 46:811 et seq.

HISTORICAL NOTE: Promulgated by the Department of Economic Development, Office of Commerce and Industry, Division of Financial Incentives, LR 19: (December 1993).

§4107. Filing of Applications

A. An "Advance Notification" of intent to file for the Louisiana Biomedical Research and Development Park tax incentives shall be filed prior to the beginning of construction, acquisition of equipment, and/or occupation of facilities. An

advance notification fee of \$100 shall be submitted with the prescribed advance notification form. Any purchases made prior to the filing of the advance notification may not be eligible for exemption and/or credit. Applications must be filed with the Office of Commerce and Industry, Box 94185, Baton Rouge, LA 70804-9185 on the prescribed form, along with any required additional information, within six months after the beginning of construction or three months before completion of construction or the beginning of operations, whichever occurs later.

B. Applications must be submitted to the Office of Commerce and Industry at least 60 days prior to the Board of Commerce and Industry meeting where it will be heard. An application fee shall be submitted with the application based on 0.2 percent of the estimated total amount of taxes to be rebated, exempted, or credited. In no case shall an application fee be smaller than \$200 and in no case shall a fee exceed \$5,000 per project. A fee of \$50 shall be charged for the renewal of a contract.

C. Within six months after construction has been completed, the applicant from the establishment shall file, on the prescribed form, an affidavit of final cost showing complete cost of the project, together with a fee of \$100 for the plant inspection which will be conducted by the Office of Commerce and Industry. Upon request by the Office of Commerce and Industry, a map showing location of all facilities claiming exemptions in the project will be submitted in order that the property for which rebates are claimed may be clearly identified.

D. The Office of Commerce and Industry reserves the right to return the advance notification, application, or affidavit of final cost to the applicant if the estimated exemptions or the fee submitted is incorrect. The document may be resubmitted with the correct fee and/or information. Documents will not be considered officially received and accepted until the appropriate fee is submitted. Processing fees, for advance notifications, applications, renewals, or affidavits of final cost which have been accepted, will not be refundable.

E. The applicant proposing a project with a construction period greater than two years must file a separate application for each construction phase. An application fee shall be submitted with each application filed, based on the fee schedule in §4107.B above.

F. The Office of Commerce and Industry is authorized to grant a six-month extension for filing of the application. An authorized representative of the Board of Commerce and Industry must approve further extension. All requests for extension must be in writing and must state why the extension is requested.

G. Please make checks payable to: Louisiana Office of Commerce and Industry.

AUTHORITY NOTE: Promulgated in accordance with R.S. 46:811 et seq.

HISTORICAL NOTE: Promulgated by the Department of Economic Development, Office of Commerce and Industry, Division of Financial Incentives, LR 19: (December 1993).

§4109. Recommendations of the Secretaries of Economic Development and Revenue and Taxation

The Office of Commerce and Industry shall forward the

application with its recommendations to the secretary of Economic Development and the secretary of Revenue and Taxation for their review. Within 30 days after the receipt of the application the secretaries of Economic Development and Revenue and Taxation shall submit their recommendations (the secretary of Revenue and Taxation shall submit a Letter of No Objection in lieu of a Letter of Recommendation) in writing to the assistant secretary of Commerce and Industry.

AUTHORITY NOTE: Promulgated in accordance with R.S. 46:811 et seq.

HISTORICAL NOTE: Promulgated by the Department of Economic Development, Office of Commerce and Industry, Division of Financial Incentives, LR 19: (December 1993).

§4111. Application Shall be Presented to the Board of Commerce and Industry

The Office of Commerce and Industry shall present an agenda of applications to the Board of Commerce and Industry with the written recommendations of the secretaries of Economic Development and Revenue and Taxation and an endorsement resolution of the local taxing authorities and shall make recommendations to the board based upon its findings.

AUTHORITY NOTE: Promulgated in accordance with R.S. 46:811 et seq.

HISTORICAL NOTE: Promulgated by the Department of Economic Development, Office of Commerce and Industry, Division of Financial Incentives, LR 19: (December 1993).

§4113. Board of Commerce and Industry Enters Into Contract

Upon approval of the application, by the governor and the Joint Legislative Committee on the Budget, the Board of Commerce and Industry shall enter into contract with the applicant for exemption of the taxes allowed by R.S. 46:813.1. A copy of the contract shall be sent to the Department of Revenue and Taxation and to the local political subdivision's tax authority.

AUTHORITY NOTE: Promulgated in accordance with R.S. 46:811 et seq.

HISTORICAL NOTE: Promulgated by the Department of Economic Development, Office of Commerce and Industry, Division of Financial Incentives, LR 19: (December 1993).

§4115. Rebates on Sales/Use Taxes

A. The contract will not authorize the applicant to make tax-free purchases from vendors.

B. State sales and use tax rebates shall be filed according to official Department of Revenue and Taxation procedures.

C. Local sales and use tax rebates shall be filed in the manner prescribed by the local taxing authority.

AUTHORITY NOTE: Promulgated in accordance with R.S. 46:811 et seq.

HISTORICAL NOTE: Promulgated by the Department of Economic Development, Office of Commerce and Industry, Division of Financial Incentives, LR 19: (December 1993).

§4117. Violations of Rules, Statutes, or Documents

On the initiative of the Board of Commerce and Industry or whenever a written complaint of violation of the terms of the rules, the contract documents, or the statutes is received, the assistant secretary for the Office of Commerce and Industry shall cause to be made a full investigation on behalf of the board, and shall have full authority for such investigation including, but not exclusively, authority to call for reports or

pertinent records or other information from the contractors. If the investigation substantiates a violation, the assistant secretary may present the subject contract to the board for formal cancellation. The businesses with contracts shall then remit any and all taxes that would have been imposed but for the issuance of a contract.

AUTHORITY NOTE: Promulgated in accordance with R.S. 46:811 et seq.

HISTORICAL NOTE: Promulgated by the Department of Economic Development, Office of Commerce and Industry, Division of Financial Incentives, LR 19: (December 1993).

§4119. Affidavits Certifying Eligibility Filed Annually

On January 15 of each year, the businesses with contracts will file an affidavit with the Office of Commerce and Industry certifying that the business still qualifies under §4105. If the affidavit shows the company no longer qualifies under this rule, the Board of Commerce and Industry shall cancel the contract and no further rebates or credits will be granted. The Department of Commerce will notify the Department of Revenue and Taxation within 30 days after revocation of a contract.

AUTHORITY NOTE: Promulgated in accordance with R.S. 46:811 et seq.

HISTORICAL NOTE: Promulgated by the Department of Economic Development, Office of Commerce and Industry, Division of Financial Incentives, LR 19: (December 1993).

§4121. Appeals Procedure

Applicants who wish to appeal the action of the Board of Commerce and Industry must submit their appeals along with any necessary documentation to the Office of Commerce and Industry at least 30 days prior to the meeting of the screening committee of the Board of Commerce and Industry during which their appeals will be heard.

AUTHORITY NOTE: Promulgated in accordance with R.S. 46:811 et seq.

HISTORICAL NOTE: Promulgated by the Department of Economic Development, Office of Commerce and Industry, Division of Financial Incentives, LR 19: (December 1993).

§4123. Income and Franchise Tax Requirements

In order for a business to benefit from the income and corporate franchise tax benefits of this Chapter, an estimated five year income and franchise tax liability must be provided to the Board of Commerce and Industry by the applicant. This information will be used only to estimate the economic impact of the project to the state.

AUTHORITY NOTE: Promulgated in accordance with R.S. 46:811 et seq.

HISTORICAL NOTE: Promulgated by the Department of Economic Development, Office of Commerce and Industry, Division of Financial Incentives, LR 19: (December 1993).

§4125. Hearing Procedures

Applicants and/or their representatives will be notified of the date of the Board of Commerce and Industry meeting at which their application will be considered. The applicant should have an officer of authority present who is able to answer any questions the Board of Commerce and Industry might have about the information contained in the application. In the event there is not a representative present, the application may be deferred.

AUTHORITY NOTE: Promulgated in accordance with R.S. 46:811 et seq.

HISTORICAL NOTE: Promulgated by the Department of Economic Development, Office of Commerce and Industry, Division of Financial Incentives, LR 19: (December 1993).

§4127. Contract Execution Procedures

A. When an application is approved, a contract is supplied to the applicant by the Office of Commerce and Industry. The applicant must execute the contract and return it within 30 days of receipt. Certified copies will then be forwarded to the proper local governmental taxing authority and to the Department of Revenue and Taxation.

B. The taxing authorities of the local governmental subdivision issuing the endorsement resolution should be contacted to determine their procedure for rebating their sales/use tax.

C. Applicants will be contacted by the staff of the Department of Revenue and Taxation who will advise the proper procedures to follow in order to obtain the state sales/use tax rebate.

D. Notification of any change which may affect the contract should be made to the Office of Commerce and Industry. This includes any changes in the ownership or operational name of the firm holding a contract or the abandonment of operation. Failure to report can constitute a breach of contract.

AUTHORITY NOTE: Promulgated in accordance with R.S. 46:811 et seq.

HISTORICAL NOTE: Promulgated by the Department of Economic Development, Office of Commerce and Industry, Division of Financial Incentives, LR 19: (December 1993).

R. Paul Adams
Director

RULE

Department of Economic Development Office of Commerce and Industry Division of Financial Incentives

University Research and Development Parks Program (LAC 13:I.Chapter 43)

The Department of Economic Development, Office of Commerce and Industry, is adopting the following rule to implement Act 990 of the 1992 Regular Session of the Louisiana Legislature.

Title 13

ECONOMIC DEVELOPMENT

Part I. Commerce and Industry

Subpart 3. Financial Incentives

Chapter 43. Louisiana University Research and Development Parks Program

§4301. General

Relief from taxation may be granted as provided under R.S. 17:3389(E).

AUTHORITY NOTE: Promulgated in accordance with R.S. 17:3389 et seq.

HISTORICAL NOTE: Promulgated by the Department of Economic Development, Office of Commerce and Industry, Division of Financial Incentives, LR 19: (December 1993).

§4303. Definitions

For purposes of these rules, the following terms shall have the meaning hereafter ascribed to them, unless the context clearly indicates otherwise:

Concerns which are *technology-based* or *innovative growth-oriented* are defined as "companies engaged in the application of science especially to industrial or commercial objectives. Such companies should be engaged in the development, manufacture, or sale of products that emerge from or depend upon the practical application of scientific or technological advances."

AUTHORITY NOTE: Promulgated in accordance with R.S. 17:3389 et seq.

HISTORICAL NOTE: Promulgated by the Department of Economic Development, Office of Commerce and Industry, Division of Financial Incentives, LR 19: (December 1993).

§4305. Qualifications

To qualify for the Louisiana University Research and Development Parks Program tax incentives an applicant must be a "concern", as defined in this rule, must provide documentation evidencing its location in a park area, must document its association with a Louisiana public or regionally accredited independent university, must document the quality of its research facility, and must demonstrate, by written statement, its viability to contribute to the improved scientific information and technology available to the citizens of Louisiana and its ability, through improved economic conditions, to stimulate the creation of jobs and the development of the park area. The statement should include all factors which are relevant to the continued and expanded operations of the applicant including, but not limited to, the following:

1. The benefits to the state in terms of continued employment opportunities, expenditures for goods and services, contributions to the revenue base of the state and local governments, and the creation of new and additional permanent jobs;
2. competitive conditions existing in other states or in foreign nations;
3. the economic viability of the applicant, and the effect of any tax exemptions or credits on economic viability;
4. the effects on the applicant of temporary supply and demand conditions;
5. the effect of casualties and/or natural disasters;
6. the effects of United States and foreign trade policies;
7. the effect of federal laws and regulations bearing on the economic viability within the state of the applicant;
8. the competitive effect of like or similar exemptions or credits granted to other applicants.

AUTHORITY NOTE: Promulgated in accordance with R.S. 17:3389 et seq.

HISTORICAL NOTE: Promulgated by the Department of Economic Development, Office of Commerce and Industry, Division of Financial Incentives, LR 19: (December 1993).

§4307. Filing of Applications

A. An "Advance Notification" of intent to file for the Louisiana University Research and Development Parks tax incentives shall be filed prior to the beginning of construction,

acquisition of equipment, and/or occupation of facilities. An advance notification fee of \$100 shall be submitted with the prescribed advance notification form. Any purchases made prior to the filing of the advance notification may not be eligible for exemption and/or credit. Applications must be filed with the Office of Commerce and Industry, Box 94185, Baton Rouge, LA 70804-9185 on the prescribed form, along with any required additional information, within six months after the beginning of construction or three months before completion of construction or the beginning of operations, whichever occurs later.

B. Applications must be submitted to the Office of Commerce and Industry at least 60 days prior to the Board of Commerce and Industry meeting where it will be heard. An application fee shall be submitted with the application based on 0.2 percent of the estimated total amount of taxes to be rebated, exempted, or credited. In no case shall an application fee be smaller than \$200 and in no case shall a fee exceed \$5,000 per project. A fee of \$50 shall be charged for the renewal of a contract.

C. Within six months after construction has been completed, the applicant from the establishment shall file, on the prescribed form, an affidavit of final cost showing complete cost of the project, together with a fee of \$100 for the plant inspection which will be conducted by the Office of Commerce and Industry. Upon request by the Office of Commerce and Industry, a map showing location of all facilities claiming exemptions in the project will be submitted in order that the property for which rebates are claimed may be clearly identified.

D. The Office of Commerce and Industry reserves the right to return the advance notification, application, or affidavit of final cost to the applicant if the estimated exemptions or the fee submitted is incorrect. The document may be resubmitted with the correct fee and/or information. Documents will not be considered officially received and accepted until the appropriate fee is submitted. Processing fees, for advance notifications, applications, renewals, or affidavits of final cost which have been accepted, will not be refundable.

E. The applicant proposing a project with a construction period greater than two years must file a separate application for each construction phase. An application fee shall be submitted with each application filed, based on the fee schedule in §4307.B above.

F. The Office of Commerce and Industry is authorized to grant a six-month extension for filing of the application. An authorized representative of the Board of Commerce and Industry must approve further extension. All requests for extension must be in writing and must state why the extension is requested.

G. Please make checks payable to: Louisiana Office of Commerce and Industry.

AUTHORITY NOTE: Promulgated in accordance with R.S. 17:3389 et seq.

HISTORICAL NOTE: Promulgated by the Department of Economic Development, Office of Commerce and Industry, Division of Financial Incentives, LR 19: (December 1993).

§4309. Recommendations of the Secretaries of Economic Development and Revenue and Taxation

The Office of Commerce and Industry shall forward the application with its recommendations to the secretary of Economic Development and the secretary of Revenue and Taxation for their review. Within 30 days after the receipt of the application the secretaries of Economic Development and Revenue and Taxation shall submit their recommendations (the secretary of Revenue and Taxation shall submit a Letter of No Objection in lieu of a Letter of Recommendation) in writing to the assistant secretary of Commerce and Industry.

AUTHORITY NOTE: Promulgated in accordance with R.S. 17:3389 et seq.

HISTORICAL NOTE: Promulgated by the Department of Economic Development, Office of Commerce and Industry, Division of Financial Incentives, LR 19: (December 1993).

§4311. Application Shall be Presented to the Board of Commerce and Industry

The Office of Commerce and Industry shall present an agenda of applications to the Board of Commerce and Industry with the written recommendations of the secretaries of Economic Development and Revenue and Taxation and an endorsement resolution of the local taxing authorities and shall make recommendations to the board based upon its findings.

AUTHORITY NOTE: Promulgated in accordance with R.S. 17:3389 et seq.

HISTORICAL NOTE: Promulgated by the Department of Economic Development, Office of Commerce and Industry, Division of Financial Incentives, LR 19: (December 1993).

§4313. Board of Commerce and Industry Enters Into Contract

Upon approval of the application, by the governor and the Joint Legislative Committee on the Budget, the Board of Commerce and Industry shall enter into contract with the applicant for exemption of the taxes allowed by R.S. 17:3389. A copy of the contract shall be sent to the Department of Revenue and Taxation and to the local political subdivision's tax authority.

AUTHORITY NOTE: Promulgated in accordance with R.S. 17:3389 et seq.

HISTORICAL NOTE: Promulgated by the Department of Economic Development, Office of Commerce and Industry, Division of Financial Incentives, LR 19: (December 1993).

§4315. Rebates on Sales/Use Taxes

A. The contract will not authorize the applicant to make tax-free purchases from vendors.

B. State sales and use tax rebates shall be filed according to official Department of Revenue and Taxation procedures.

C. Local sales and use tax rebates shall be filed in the manner prescribed by the local taxing authority.

AUTHORITY NOTE: Promulgated in accordance with R.S. 17:3389 et seq.

HISTORICAL NOTE: Promulgated by the Department of Economic Development, Office of Commerce and Industry, Division of Financial Incentives, LR 19: (December 1993).

§4317. Violations of Rules, Statutes, or Documents

On the initiative of the Board of Commerce and Industry or whenever a written complaint of violation of the terms of the rules, the contract documents, or the statutes is received, the assistant secretary for the Office of Commerce and Industry

shall cause to be made a full investigation on behalf of the board, and shall have full authority for such investigation including, but not exclusively, authority to call for reports or pertinent records or other information from the contractors. If the investigation substantiates a violation, the assistant secretary may present the subject contract to the board for formal cancellation. The businesses with contracts shall then remit any and all taxes that would have been imposed but for the issuance of a contract.

AUTHORITY NOTE: Promulgated in accordance with R.S. 17:3389 et seq.

HISTORICAL NOTE: Promulgated by the Department of Economic Development, Office of Commerce and Industry, Division of Financial Incentives, LR 19: (December 1993).

§4319. Affidavits Certifying Eligibility Filed Annually

On January 15th of each year, the businesses with contracts will file an affidavit with the Office of Commerce and Industry certifying that the business still qualifies under §4304. If the affidavit shows the company no longer qualifies under this rule, the Board of Commerce and Industry shall cancel the contract and no further rebates or credits will be granted. The Department of Commerce will notify the Department of Revenue and Taxation within 30 days after revocation of a contract.

AUTHORITY NOTE: Promulgated in accordance with R.S. 17:3389 et seq.

HISTORICAL NOTE: Promulgated by the Department of Economic Development, Office of Commerce and Industry, Division of Financial Incentives, LR 19: (December 1993).

§4321. Appeals Procedure

Applicants who wish to appeal the action of the Board of Commerce and Industry must submit their appeals along with any necessary documentation to the Office of Commerce and Industry at least 30 days prior to the meeting of the screening committee of the Board of Commerce and Industry during which their appeals will be heard.

AUTHORITY NOTE: Promulgated in accordance with R.S. 17:3389 et seq.

HISTORICAL NOTE: Promulgated by the Department of Economic Development, Office of Commerce and Industry, Division of Financial Incentives, LR 19: (December 1993).

§4323. Income and Franchise Tax Requirements

In order for a business to benefit from the income and corporate franchise tax benefits of this Chapter, an estimated five year income and franchise tax liability must be provided to the Board of Commerce and Industry by the applicant. This information will be used only to estimate the economic impact of the project to the state.

AUTHORITY NOTE: Promulgated in accordance with R.S. 17:3389 et seq.

HISTORICAL NOTE: Promulgated by the Department of Economic Development, Office of Commerce and Industry, Division of Financial Incentives, LR 19: (December 1993).

§4325. Hearing Procedures

Applicants and/or their representatives will be notified of the date of the Board of Commerce and Industry meeting at which their application will be considered. The applicant should have an officer of authority present who is able to answer any questions the Board of Commerce and Industry might have about the information contained in the application. In the

event there is not a representative present, the application may be deferred.

AUTHORITY NOTE: Promulgated in accordance with R.S. 17:3389 et seq.

HISTORICAL NOTE: Promulgated by the Department of Economic Development, Office of Commerce and Industry, Division of Financial Incentives, LR 19: (December 1993).

§4327. Contract Execution Procedures

A. When an application is approved, a contract is supplied to the applicant by the Office of Commerce and Industry. The applicant must execute the contract and return it within 30 days of receipt. Certified copies will then be forwarded to the proper local governmental taxing authority and to the Department of Revenue and Taxation.

B. The taxing authorities of the local governmental subdivision issuing the endorsement resolution should be contacted to determine their procedure for rebating their sales/use tax.

C. Applicants will be contacted by the staff of the Department of Revenue and Taxation who will advise the proper procedures to follow in order to obtain the state sales/use tax rebate.

D. Notification of any change which may affect the contract should be made to the Office of Commerce and Industry. This includes any changes in the ownership or operational name of the firm holding a contract or the abandonment of operation. Failure to report can constitute a breach of contract.

AUTHORITY NOTE: Promulgated in accordance with R.S. 17:3389 et seq.

HISTORICAL NOTE: Promulgated by the Department of Economic Development, Office of Commerce and Industry, Division of Financial Incentives, LR 19: (December 1993).

R. Paul Adams
Director

RULE

**Department of Economic Development
Office of Financial Institutions**

**Financial Institutions Fees and Assessments
(LAC 10:I.110, 201, 203 and LAC 10:V.5101)**

Under the authority of the provisions contained in R.S. 126(A) and R.S. 6:646(B)(5), and in accordance with the provisions of R.S. 49:950 et seq., the Administrative Procedure Act, the commissioner of the Office of Financial Institutions has adopted the following rules and repealed certain existing rules to provide for the levy of fees and assessments upon banks, savings and loan associations, savings banks, their respective parent holding companies and corporate credit unions.

LAC 10:I.11, 201, 203 and LAC 10:V.5105 become effective January 1, 1994.

(Editor's Note: LAC Title 10 has been recodified with new Part numbers; Chapter numbers within each Part remain the same.)

Title 10

**FINANCIAL INSTITUTIONS, CONSUMER CREDIT,
INVESTMENT SECURITIES AND UCC**

**Part I. Financial Institutions
(formerly Part I. Banks)**

Chapter 1. General Provisions

§110. Assessments

Repealed.

AUTHORITY NOTE: Promulgated in accordance with R.S. 6:121(B)(1) and 242(A)(15).

HISTORICAL NOTE: Promulgated by the Department of Commerce, Office of Financial Institutions, LR 14:608 (September 1980), repromulgated by the Department of Economic Development, Office of Financial Institutions, LR 14:699 (October 1988), repealed LR 19: (December 1993).

Chapter 2. Fees and Assessments

§201. Establishment of Fees and Assessments

<i>DESCRIPTION</i>	<i>FEE</i>
A. For the reservation of a corporate name of a state bank, savings and loan association, or savings bank.	\$ 100
B. Application for a de novo state bank, savings and loan association or savings bank charter, or the merger or consolidation of two banks, savings and loan associations, or savings banks. An additional \$5,000 fee will be charged for each additional institution affected. Includes conversion from national bank or federal savings and loan association or savings bank to state bank, savings and loan association or savings bank. Fee is non-refundable.	\$10,000
C. Application for a state bank, savings and loan association or savings bank for a branch office. Fee is non-refundable.	\$ 1,000

D. Processing fee for application to acquire a failing or failed institution. Fee is non-refundable. If applicant is successful bidder, processing fee will be applied to application fee(s) as set forth in B and C above:	
1. Existing state-chartered financial institution.	\$ 500/per branch
2. De Novo state-chartered financial institution.	\$ 5,000
E. Application for a state bank, savings and loan association, or savings bank for an off-site electronic financial terminal machine. Fee is non-refundable.	\$ 500
F. Application for a conversion or merger of a state-chartered bank, savings and loan association, or savings bank into a national bank, a federal savings and loan association, or a federal savings bank. Fee is non-refundable.	\$ 1,500
G. Application for organization and/or merger of a stock or mutual holding company for an already existing bank, savings and loan association, or savings bank (phantom). Fee is non-refundable.	\$ 2,000
H. Application to relocate a bank, savings and loan association or savings bank main office or branch office. Fee is non-refundable.	\$ 1,000
I. Special examination fee for state bank, savings and loan association, or savings bank. Fee per examiner.	\$ 50/hour
J. Semi-annual assessment of each state-chartered bank, savings and loan association, and savings bank at a floating rate to be assessed no later than June 30 and December 31, to be based on the total consolidated average assets, for the preceding quarter. Not applicable to trust banks. Any amounts collected in excess of actual expenditures of the Office of Financial Institutions shall be credited or refunded on a pro rata basis. Any shortages in assessments to cover actual operating expenses of OFI shall be added to the next variable assessment or billed on a pro rata basis.	Variable
K. Annual assessment of each holding company domiciled in and/or operating in Louisiana, to be assessed no later than September 30 of each year to be based upon the holding company's total consolidated assets as of the previous June 30, in accordance with the following schedule:	
1. Assets less than \$100,000,000	\$ 350
2. Assets of \$100,000,000 to \$149,999,999	\$ 500
3. Assets of \$150,000,000 or greater	\$ 650
L. Examination fee for holding companies of each bank, savings and loan association, or savings bank domiciled in and/or operating in Louisiana. Fee per examiner.	\$ 50/hour
M. Application by an in-state financial institution to establish an in-state and/or out-of-state loan or trust production office. Fee is non-refundable.	\$ 50

N. Application by an out-of-state financial institution to establish an in-state loan or trust production office. Fee is non-refundable.	\$ 50
O. Semi-annual assessment for each bank limited to the exercise of trust powers only and domiciled and operating in Louisiana to be assessed no later than June 30 and December 31.	\$ 500
P. Examination fee for each trust bank domiciled and operating in Louisiana. Fee per examiner.	\$ 50/hour
Q. Examination fee for trust department of state-chartered bank, savings and loan association, or savings bank. Fee per examiner.	\$ 50/hour
R. Examination of registered transfer agent activities of state-chartered bank, savings and loan association, or savings bank. Fee per examiner.	\$ 50/hour
S. Review of restatement and/or amendment to the Articles of Incorporation of a state-chartered bank, savings and loan association, or savings bank. Fee is non-refundable.	\$ 250
T. Replacement charter and/or branch certificate.	\$ 100/per certificate
U. Petition by a bank, savings and loan association, or savings bank to exceed its legal lending limit to finance the sale of other real estate.	for each request: the > of \$500 or actual costs at \$50/hour
V. Filing of agreement for substitution of fiduciary between two or more institutions authorized to exercise fiduciary powers, pursuant to LSA-R.S. 9:2130.	\$ 25
W. Application by state-chartered bank, savings and loan association, or savings bank to exercise trust powers and/or re-institute trust powers formerly surrendered. Fee is non-refundable.	\$ 1,000
X. Application by a state-chartered bank, savings and loan association, or savings bank to establish or acquire a subsidiary or service corporation. Fee is non-refundable.	\$ 1,000
Y. Application by an in-state or out-of-state holding company to acquire a Louisiana bank or bank holding company or an out-of-state bank holding company with a Louisiana bank subsidiary(ies), pursuant to La. R.S.6:535. Fee is non-refundable.	\$ 1,000 application fee (plus \$10,000 if de novo charter also required)
Z. Corporate Credit Union Examination Fee. Base fee will be \$2,000 for 1994, with an annual increase of \$1,000 per year, not to exceed \$5,000, plus \$400 per day per examiner.	
AA. Application by a state-chartered bank, savings and loan association, or savings bank to merge with its parent holding company. Fee is non-refundable.	\$ 1,000
AB. Processing fee for a certificate of authority filed by state-chartered savings and loan associations or savings banks not domiciled in Louisiana to operate a branch in the state. Fee is non-refundable.	\$ 1,000

AC. Application for conversion by any state-chartered depository institution to another state-charter. Fee is non-refundable.	\$ 1,500
AD. Fee for late submission of a call report or thrift financial report to the Commissioner.	\$ 100/per day

1978), repealed by the Department of Economic Development, Racing Commission, LR 19: (December 1993).

Paul D. Burgess
Executive Director

AUTHORITY NOTE: Promulgated in accordance with R.S. 126(A) and R.S. 6:646(B)(5).

HISTORICAL NOTE: Promulgated by the Department of Economic Development, Office of Financial Institutions, LR 19: (December 1993).

§203. Administration

A. The commissioner may increase any of the above fees when a combination of two or more of the transactions described above occur, said fee not to exceed the lesser of \$50 per hour, or the combined fees as stated above.

AUTHORITY NOTE: Promulgated in accordance with R.S. 6:126(A) and R.S. 6:646(B)(5).

HISTORICAL NOTE: Promulgated by the Department of Economic Development, Office of Financial Institutions, LR 19: (December 1993).

Part V. Thrifts

(formerly Part III. Homestead and Building and Loan Associations)

Chapter 51. Assessments

§5101. Fees

Repealed.

AUTHORITY NOTE: Promulgated in accordance with R.S. 6:121(B)(1) and 911(E).

HISTORICAL NOTE: Promulgated by the Department of Economic Development, Office of Financial Institutions, LR 15:465 (June 1989), repealed LR 19: (December 1993).

Larry L. Murray
Commissioner

RULE

**Department of Economic Development
Racing Commission**

Health Certificate Necessary (LAC 35:I.1303)

The Department of Economic Development, Racing Commission hereby repeals LAC 35:I.1303, Health Certificate Necessary, since it is obsolete.

Title 35

HORSE RACING

Part I. General Provisions

Chapter 13. Health Rules

§1303. Health Certificate Necessary

Repealed in its entirety.

AUTHORITY NOTE: Promulgated in accordance with R.S. 4:141 and 142.

HISTORICAL NOTE: Adopted by the Louisiana State Racing Commission in 1971, amended and promulgated by the Department of Commerce, Racing Commission, LR 2:423 (December 1976), repromulgated LR 3:19 (January 1977), amended LR 4:271 (August

RULE

Board of Elementary and Secondary Education

**Bulletin 1921—Annual Special Education Program and
Bulletin 1927—Pre-School Grant Application
(LAC 28:I.937)**

In accordance with R.S. 49:950 et seq., the Administrative Procedure Act, the Board of Elementary and Secondary Education adopted Bulletin 1921, Annual Special Education Program Plan (IDEA-B) for FY 94-96, and Bulletin 1927, Pre-school Grant Application.

The Annual Special Education Program Plan (IDEA-B) and the Pre-school Grant Application may be seen in their entirety in the Office of the State Register, 1051 North Third Street, Capitol Annex, Fifth Floor, Baton Rouge, LA 70802.

The Louisiana Special Education Program Plan and Bulletin 1927, Pre-school Grant Application are referenced in LAC Title 28 as noted below:

**Title 28
EDUCATION**

**Part I. Board of Elementary and Secondary Education
Chapter 9. Bulletins, Regulations, and State Plans
§937. Special Education State Plan**

A. Bulletin 1921, the Revised Louisiana Annual Special Education Program Plan, for Fiscal Years 1994-1996 is adopted, along with Bulletin 1927, Pre-school Grant Application.

* * *

AUTHORITY NOTE: Promulgated in accordance with Section 1419 of IDEA-B, Section 619, P. L. 102-119 (Preschool 3-5 Grant) (CFDA 84.173); R. S. 17:1944, and 1948.

Carole Wallin
Executive Director

RULE

Board of Elementary and Secondary Education

Bulletin 1934—Starting Points Preschool Regulations (LAC 28:I.906)

In accordance with R.S. 49:950 et seq., the Administrative Procedure Act, the Board of Elementary and Secondary Education amended Bulletin 1934, Starting Points Preschool Regulations. These regulations were also adopted as an emergency rule and printed in full in the August 1993 issue of the *Louisiana Register*. Bulletin 1934 will be referenced in LAC Title 28 as follows:

Title 28 EDUCATION

Part I. Board of Elementary and Secondary Education Chapter 9. Bulletins, Regulations, and State Plans §906. Early Childhood Programs

* * *

B. Bulletin 1934, Starting Points Preschool Regulations is adopted. Local Starting Points Preschool Programs will adhere to the developmental philosophy as outlined by the National Association for the Education of Young Children. Developmentally appropriate practices have been proven to be effective in early childhood education. Inherent in this philosophy is the provision of a child-centered program directed toward the development of cognitive, social, emotional, communication and motor skills in a manner and at a pace consistent with the needs and capabilities of the individual child.

AUTHORITY NOTE: Promulgated in accordance with 12291 Federal Regulations 45 CFR, Parts 98 and 99.

Carole Wallin
Executive Director

RULE

Board of Elementary and Secondary Education

Child and Adult Care Food Program (LAC 28:I.944)

In accordance with R.S. 49:950 et seq., the Administrative Procedure Act, the Board of Elementary and Secondary Education approved the following rules and regulations for the Child Care Registration for Participants in the Child and Adult Care Food Program as mandated by Act 925 of 1993. These regulations will be included in LAC Title 28 and were adopted as an emergency rule, effective July 22, 1993.

Title 28 EDUCATION

Part I. Board of Elementary and Secondary Education Chapter 9. Bulletins, Regulations, and State Plans §944. Child and Adult Care Food Program

Child Care Registration for Participants in the Child and

Adult Care Food Program. In compliance with R.S. 46:1441.4(B), the following rules and regulations are hereby established to carry out the provisions of this Chapter for those family child day care homes and group child day care homes which participate in the federal Child and Adult Care Food Program.

1. Definitions. As established by R.S. 1441.1 and as used in these rules and regulations, the following definitions shall apply unless the context clearly states otherwise.

Child—a person who has not reached the age of 13 years. The words "child" and "children" are used interchangeably in this Chapter.

Child and Adult Care Food Program—the federal nutrition reimbursement program as funded by the federal Department of Agriculture through the state Department of Education.

Department—the Department of Health and Hospitals or the Department of Social Services or the Department of Education in accordance with 7 CFR Part 226, as indicated by the context.

Family Child Day Care Home—any place, facility, or home operated by any institution, society, agency, corporation, person or persons, or any other group for the primary purpose of providing care, supervision, and/or guidance of six or fewer children.

Group Child Day Care Home—any place, facility, or home operated by any institution, society, agency, corporation, person or persons, or any other group for the primary purpose of providing care, supervision, and/or guidance of seven but not more than 12 children.

Sponsoring Agency—any private, public, for profit or nonprofit corporation, society, agency, or any other group approved by or contracted with the Department of Education to coordinate family child day care homes and group child day care homes participating in the federal Child and Adult Care Food Program.

2. All Group Child Day Care Homes which participate in the Child and Adult Care Food Program (CACFP) shall be licensed through the Louisiana Department of Social Services in accordance with the provisions of R.S. 46:1401-1424.

3. All Family Child Day Care Homes which participate in the Child and Adult Care Food Program (CACFP) shall be registered through the Louisiana Department of Education according to the following criteria:

a. the facility shall be the private residence of the child care provider;

b. the provider shall enter into the required program agreement with a Louisiana Department of Education-approved CACFP sponsor;

c. the provider shall attend a minimum of one sponsor-conducted training session per year;

d. no more than six children shall be in attendance at the facility;

e. the facility shall be inspected and approved in accordance with R.S. 46:1441. Inspection criteria shall be as follows:

i. matches, lighters and other sources of ignition shall be kept out of reach of children;

ii. portable electric heaters shall be of an approved

type, shall be equipped with a tilt switch and shall be located away from combustibles;

iii. at least one smoke detector shall be properly installed, located and maintained;

iv. protective receptacle covers shall be installed in all areas occupied by children under five years of age;

v. every room used for sleeping, living, or dining purposes shall have at least two means of escape, at least one which is a door or stairway providing a means of unobstructed travel to the outside of the building. If the home has burglar bars, the burglar bars shall have either release latches or keys in the locks during all hours of child care. If the home has doors with dead bolt locks, the dead bolt locks shall have keys inserted in the locks during all hours of child care. If the home has jalousie windows which do not meet size requirements, the rooms shall not be used for sleeping during any hours of child care;

vi. stairways shall be maintained free of storage items;

vii. every closet door shall be designed to permit the opening of the locked door from inside the closet;

viii. every bathroom door lock must be designed to permit the opening of the locked door from the outside in an emergency. The opening device must be readily accessible;

ix. a properly charged portable fire extinguisher (minimum 2A) must be readily accessible;

x. the hot water heater shall be properly installed;

xi. the facility shall have adequate lighting and ventilation;

xii. unvented fuel-fired room heaters shall be used only in rooms in which a window is raised;

xiii. flammable liquids shall be properly stored;

xiv. combustibles shall be stored away from heating units or water heaters;

xv. wiring, fixtures and appliances in the facility shall be safe;

xvi. the facility shall have an adequate water supply and a working sewerage system;

xvii. the facility shall be clean and free of insect and rodent infestation;

xviii. garbage shall be disposed of properly;

xix. the temperature of the refrigerator shall be maintained at or below 45° F. (A thermometer shall be left in the refrigerator for at least 10 minutes to achieve an accurate reading).

f. The facility inspection as referenced in §944.3.e above shall be conducted annually. However, facilities which are complying with applicable procedures to renew registration may participate in the CACFP during the renewal process unless the Department of Education has information which indicates that renewal will be denied.

AUTHORITY NOTE: Promulgated in accordance with R.S. 46:1441.4(b).

Carole Wallin
Executive Director

RULE

Board of Elementary and Secondary Education

Technical Institutes Refund Policy (LAC 28:I.1523)

In accordance with R.S. 49:950 et seq., the Administrative Procedure Act, the Board of Elementary and Secondary Education amended the refund policy of the technical institutes. This amendment to LAC Title 28, as stated below, and was adopted as an emergency rule, and printed in the August 1993 issue of the *Louisiana Register*. Effective date of the emergency rule was July 22, 1993.

Title 28

EDUCATION

Part I. Board of Elementary and Secondary Education

Chapter 15. Vocational and Vocational-Technical Education

§1523. Students

* * *

E. Fees for Louisiana Residents

* * *

3. Refund Policy

a. Enrollment or re-enrollment payments, or acceptable evidence of indebtedness, shall be due upon registration or re-enrollment, as part of the enrollment process. These fees are non-refundable except where the class is canceled or closed.

b. Title IV Recipient Pro Rata Refund Policy:

i. This pro rata refund policy applies only to students who are first-time enrollees *and* who are recipients of Title IV funds. This requirement does not apply to any student whose withdrawal date is after 60 percent of the enrollment period has transpired.

ii. Each institution shall refund a portion of unearned tuition and fees assessed students who are recipients of Title IV funds, if the student fails to complete the period of enrollment for which the Title IV funds were provided.

iii. The refund shall be equal to tuition for that portion of the period of enrollment for which the student has been charged that remains on the student's last day of attendance, rounded downward to the nearest 10 percent of that period. Any refund shall be reduced by an administrative fee not to exceed five percent of the tuition for the enrollment period.

iv. Refunds shall be credited to the following programs in this order:

(a). outstanding balances on Part B, D, and E loans,

(b). awards for PELL, SEOG, and CW-S programs,

(c). to other Title IV student assistance programs, and

(d). any other agency paying tuition. Students shall not receive a refund of tuition.

* * *

AUTHORITY NOTE: Promulgated in accordance with R.S. 17:6(A)(10)(11) and R.S. 17:1997.

Carole Wallin
Executive Director

RULE

Board of Elementary and Secondary Education

Technical Institutes Tuition Fees (LAC 28:I.1523)

In accordance with R.S. 49:950 seq., the Administrative Procedure Act, the Board of Elementary and Secondary Education amended LAC 28:I.1523.E as stated below. This amendment increases the tuition fee for the technical institutes from \$300 to \$420 per year, and was adopted as an emergency rule, effective August 30, 1993.

Title 28

EDUCATION

**Part I. Board of Elementary and Secondary Education
Chapter 15. Vocational and Vocational-Technical
Education**

§1523. Students

E. Fees for Louisiana Residents

1. Registration and Fee Schedule

b. Residents shall pay in advance, the following tuition fees: (effective August 30, 1993)

Full-time	\$35.00 per month
3/4 time	\$26.25 per month
1/2 time	\$17.50 per month

AUTHORITY NOTE: Promulgated in accordance with R.S. 17:6(A)(10)(11); R.S. 17:1997.

Carole Wallin
Executive Director

RULE

**Department of Education
Board of Regents**

**Registration, Licensure and Consumer
Protection (LAC 28:IX.Chapters 1, 3 and 5)**

In accordance with R.S. 49:950 et seq., the Administrative Procedure Act, and R.S. 17:1808 which delegates the authority to the Board of Regents to set rules for registration and licensure of postsecondary academic degree-granting institutions, and R.S. 17:3125-3382 which authorizes the Board of Regents to coordinate postsecondary academic degree-granting institutions, the Board of Regents approved the following rules for registration and licensure:

Title 28

EDUCATION

Part IX. Regents

Chapter I. Rules for Registration and Licensure

§101. Definition of Terms

Terms used in these regulations such as *Board of Regents*,

Postsecondary, Academic Degree-granting Institution, Registration, Licensure, and Fees shall be interpreted in accordance with R.S. 17:1808.

AUTHORITY NOTE: Promulgated in accordance with R.S. 17:1808.

HISTORICAL NOTE: Promulgated by the Department of Education, Board of Regents, LR 19: (December 1993).

§103. Registration and License Applications

A. All public and private postsecondary, academic degree-granting institutions offering instruction in the state of Louisiana must register annually with the Board of Regents. Regular licenses are reviewed every two years. Requests for registration forms and license applications should be made in writing and addressed to:

Commissioner of Higher Education
Louisiana Board of Regents
150 Third Street, Suite 129
Baton Rouge, LA 70801-1389

B. Completed registration forms and license applications should be returned to the address shown above.

C. License applications must be accompanied by a nonrefundable license application fee of \$500. The license application fee must be paid by company or institutional check or by money order, and should be made payable to the Louisiana Board of Regents.

AUTHORITY NOTE: Promulgated in accordance with R.S. 17:1808.

HISTORICAL NOTE: Promulgated by the Department of Education, Board of Regents, LR 19: (December 1993).

§105. License Fees

A. The license application fee shall be \$500. Those institutions granted a license to operate will be required to pay an additional \$500 at the start of the second year of the two-year licensing period. License renewal fees are required during each subsequent two-year licensing period and are nonrefundable.

B. If a request for license renewal is not received at the Board of Regents' offices at least 30 days prior to its expiration date, the institution will be subject to a delinquent fee of \$500 in addition to the renewal fee.

C. The Board of Regents may authorize assessment of special or supplemental fees to be paid by registered institutions pursuant to special actions or requests.

D. Institutions seeking licensure shall submit all required materials and the nonrefundable license fee to the Board of Regents. If a final determination concerning the institution's qualifications for licensure is not reached within 60 days of receipt of the license application, a provisional license will be issued to the institution. The provisional license will remain in effect pending a final licensing decision by the board.

AUTHORITY NOTE: Promulgated in accordance with R.S. 17:1808.

HISTORICAL NOTE: Promulgated by the Department of Education, Board of Regents, LR 19: (December 1993).

§107. Information Requirements for Registration¹

A. All postsecondary, academic degree-granting institutions are required to provide the following information on an annual basis:

1. name and in-state address of the institution;
2. location of its main campus or office;

3. a role, scope, and mission statement;
4. degrees offered in Louisiana;
5. courses offered in Louisiana;
6. the name of the institution's chief executive officer and chief financial officer;
7. names and addresses of the institution's governing board members, if applicable;
8. description of its physical facilities in Louisiana;
9. information relative to the institution's accreditation or official candidacy status from a regional or professional accrediting agency recognized by the United States Department of Education;
10. other information as specified by the Board of Regents.

¹Registration with the Board of Regents shall in no way constitute state approval or accreditation of any institution and shall not be used in any form of advertisement by any institution.

AUTHORITY NOTE: Promulgated in accordance with R.S. 17:1808.

HISTORICAL NOTE: Promulgated by the Department of Education, Board of Regents, LR 19: (December 1993).

Chapter 3. Criteria and Requirements for Licensure

§301. General Standards

A. General standards for public and private academic degree-granting institutions offering similar degrees and titles should be as close as possible. Institutions with main campuses outside the state of Louisiana must submit documentation showing that they are operating legally and in accordance with rules and regulations governing postsecondary, academic degree-granting institutions in the state in which the institution is primarily domiciled. Institutions reporting to be domiciled in Louisiana must maintain an established physical presence in the state including appropriate instructional and/or administrative facilities, faculties, staff, equipment, services, and library resources as necessary and of sufficient quality according to the type and level of degrees offered and the delivery system employed by the institution. Institutions domiciled in Louisiana, but offering educational services outside the state, must provide evidence that students have sufficient access to necessary resources and facilities appropriate to the type and level of degrees offered by the institution. The following standards shall apply to all postsecondary academic degree-granting institutions seeking licensure in the state of Louisiana.

AUTHORITY NOTE: Promulgated in accordance with R.S. 17:1808.

HISTORICAL NOTE: Promulgated by the Department of Education, Board of Regents, LR 19: (December 1993).

§303. Faculty

A. Qualifications of Faculty

1. Faculty shall be qualified by education and experience in the fields in which they teach. Faculty should meet the following minimum requirements:

- a. Faculty shall possess no less than the degree awarded to a graduate of the program in which they are teaching.
- b. The faculty shall be sufficient in number to establish and maintain the effectiveness of the educational program.

B. Institutions offering advanced degrees should employ

faculty who hold advanced degrees in appropriate fields from institutions accredited by recognized agencies¹. It is required that faculty credentials be verifiable.

1. If any institution employs a faculty member whose highest earned degree is from a non-regionally accredited institution within the United States or an institution outside the United States, the institution must show evidence that the faculty member has appropriate academic preparation.

2. It is the responsibility of the institution to keep on file for all full-time and part-time faculty members documentation of academic preparation, such as official transcripts, and if appropriate for demonstrating competency, official documentation of professional and work experience, technical and performance competency, records of publications, and certifications and other qualifications.²

¹Recognized accrediting agencies are those approved by the United States Department of Education.

²Source: Southern Association of Colleges and Schools.

AUTHORITY NOTE: Promulgated in accordance with R.S. 17:1808.

HISTORICAL NOTE: Promulgated by the Department of Education, Board of Regents, LR 19: (December 1993).

§305. Academic Program Standards

A. All curricula leading to academic credits, certification, and degrees shall be formulated and evaluated by qualified faculty with appropriate education and experience acceptable to public postsecondary, academic degree-granting institutions in Louisiana and elsewhere in the nation.

B. Institutions shall provide prospective students and other interested persons with the following information:

1. admissions policies;
2. program descriptions and objectives;
3. schedule of tuition, fees, and other charges;
4. cancellation and refund policies;
5. other material information about the institution and its programs which may impact a student's enrollment decision.

C. Institutions must provide programs of sufficient quality and content to achieve stated learning objectives. Institutions are also required to establish procedures for evaluating program effectiveness.

D. Institutions must indicate the means for determining satisfactory academic progress and provide data on student retention, graduation rates, job placement, and passing rates on licensure or certification exams, where appropriate.

E. Currently licensed institutions seeking to implement new academic degree programs must first advise the Board of Regents of the proposed change. New programs will be reviewed as part of the regular license renewal process.

AUTHORITY NOTE: Promulgated in accordance with R.S. 17:1808.

HISTORICAL NOTE: Promulgated by the Department of Education, Board of Regents, LR 19: (December 1993).

§307. Physical Plant Standards

A. Library

1. The institution shall maintain and/or provide student access to an appropriate library collection with adequate support staff, services, and equipment. Any contractual agreements with libraries not directly affiliated with the institution shall be available in writing to the Board of Regents.

B. Facilities and Equipment

1. The institution shall maintain or provide access to appropriate administrative, classroom, and laboratory space, and appropriate equipment and instructional materials to support quality education at the level being offered. Facilities must comply with all health and safety laws and ordinances.

AUTHORITY NOTE: Promulgated in accordance with R.S. 17:1808.

HISTORICAL NOTE: Promulgated by the Department of Education, Board of Regents, LR 19: (December 1993).

§309. Financial Operations

A. The business and financial management of the institution shall be directed by a qualified and bonded business officer responsible to the institution's chief executive officer.

B. Institutions are required to maintain adequate insurance to protect the operation of the institution and to guard against any personal or public liability.

C. All institutions shall provide the Board of Regents with a financial review prepared in accordance with standards established by the American Institute of Certified Public Accountants. However, any institution accredited by an agency recognized by the United States Department of Education may, at its discretion, submit financial statements prepared in accordance with rules and guidelines established by the accrediting agency.

D. Institutions shall maintain and update a long-range financial development plan for the institution.

AUTHORITY NOTE: Promulgated in accordance with R.S. 17:1808.

HISTORICAL NOTE: Promulgated by the Department of Education, Board of Regents LR 19: (December 1993).

§311. Maintenance of Records

A. Institutions are required to keep records for a minimum of three years which detail:

1. the composition and background of students, faculty, and administrative staff;

2. the institution's physical plant including land, buildings, library, and research facilities;

3. copies of brochures, catalogs, and advertising which describe student admissions, programs, and scholarships.

B. A student's records should be available for review by that student at the institution's central office.

C. Individual student records should include an enrollment agreement which at a minimum contain:

1. the name and address of the student;

2. commencement date of the program;

3. titles of courses within the student's chosen curriculum;

4. total hours (quarter, trimester, semester);

5. a payment schedule which includes the total cost to the student;

6. the refund policy of the institution;

7. a statement indicating that the individual signing the agreement has read and understands all aspects of the agreement;

8. student grievance procedures.

D. Student records should also include:

1. grades received;

2. all obligations incurred and all funds paid by the student to the institution;

3. student attendance information;

4. counseling records;

5. a transcript;

6. financial aid records.

E. Student records shall be available and readily accessible for use and review by authorized officials of the institution and authorized representatives of the Board of Regents.

AUTHORITY NOTE: Promulgated in accordance with R.S. 17:1808.

HISTORICAL NOTE: Promulgated by the Department of Education, Board of Regents, LR 19: (December 1993).

§313. Student Services¹

A. Institutions shall provide orientation and counseling services throughout enrollment. Special services including financial aid, employment placement for graduates, and student housing, if appropriate, must be evaluated periodically by the institution to determine effectiveness in meeting student needs and contribution to the educational purpose of the institution.

¹The Board of Regents recommends that prospective students seek independent job/career counseling prior to enrollment in an academic degree-granting postsecondary institution and encourages such institutions to promote this recommendation.

AUTHORITY NOTE: Promulgated in accordance with 17:1808.

HISTORICAL NOTE: Promulgated by the Department of Education, Board of Regents, LR 19: (December 1993).

§315. Organization and Administration

A. An institution shall establish a governing structure which delineates responsibility for institutional operations, policy formation, and the selection of the institution's chief executive officer. If the institution is governed by a board or group of officers, the role and responsibilities of that body should be clearly defined.

B. Administrative personnel should possess qualifications which support the institution's stated purpose and effective operation.

AUTHORITY NOTE: Promulgated in accordance with R.S. 17:1808.

HISTORICAL NOTE: Promulgated by the Department of Education, Board of Regents, LR 19: (December 1993).

§317. Procedures for Tuition and Fee Refunds

A. Pricing and Refund Policy

1. The institution must fully disclose all charges and fees in writing to prospective students. The parent or guardian of prospective students under legal adult age must be notified in writing of all charges and fees prior to enrollment.

2. Prospective students shall not be required to make a nonrefundable tuition payment until it has been determined that the prospective student has been accepted for enrollment.

3. The institution's refund policy must be disclosed in any contract to be signed by the prospective student or the student's legal adult guardian.

4. Institutions are required to follow the minimum standards for tuition refunds as set forth herein. These guidelines are:

a. students who withdraw prior to the first day of classes are entitled to a full refund of tuition and fees. Institutions may, however, require a nonrefundable application fee;

b. any administrative fees retained by the institution upon the early withdrawal of a student shall not exceed 15 percent of the total cost of tuition and fees paid by the student;

c. institutions which financially obligate students on a quarter, semester, or similar basis will be subject to the following tuition and fee refund policy:

i. students withdrawing during the first 10 days of classes shall receive a minimum refund of 75 percent of total tuition and fees paid, excluding any nonrefundable application fees, less the maximally-allowable administrative fees retained by the institution;

ii. students withdrawing from day 11 through day 24 of classes shall receive a minimum refund of 50 percent of total tuition and fees paid, excluding any nonrefundable application fees, less the maximally-allowable administrative fees retained by the institution;

iii. students withdrawing from day 25 through the end of the quarter, semester, or similar time period are ineligible to receive a refund;

d. institutions which financially obligate students for longer periods of time, i.e., periods exceeding six months, shall be subject to the following tuition and fee refund policy:

i. students completing up to 25 percent of the course of study shall receive a minimum refund of 50 percent of total tuition and fees paid, excluding any nonrefundable application fees, less the maximally-allowable administrative fees retained by the institution;

ii. students completing more than 25 percent but less than 50 percent of the course of study shall receive a minimum refund of 25 percent of total tuition and fees paid, excluding any nonrefundable application fees, less the maximally-allowable administrative fees retained by the institution;

iii. institutions are not allowed to keep the full amount of tuition and fee charges until at least half the program of study has been completed;

iv. refund policies for programs offering tuition/fee payments on an installment plan will be examined by the Board of Regents on an individual basis. Refund policies for installment programs are expected to conform generally to refund policies which appear in Subsection A.4.c.i. through iii. and d.i. through iv. of this Section.

e. Refunds should be paid within 45 days of the date of withdrawal of the student from the institution.

AUTHORITY NOTE: Promulgated in accordance with R.S. 17:1808.

HISTORICAL NOTE: Promulgated by the Department of Education, Board of Regents, LR 19: (December 1993).

§319. Surety Bonding

A. Institutions are required to post a surety bond issued by a surety authorized to do business in the state of Louisiana in the amount of \$10,000 to cover the period of the license. These bonds are intended to protect students in the event of a sudden closure of the institution. Institutions that are also licensed and bonded under provisions set forth by the Louisiana Board of Elementary and Secondary Education (BESE) need not seek additional bonding.

AUTHORITY NOTE: Promulgated in accordance with R.S. 17:1808.

HISTORICAL NOTE: Promulgated by the Department of Education, Board of Regents, LR 19: (December 1993).

§321. Rules and Guidelines on Advertising¹

A. Registration with the Board of Regents shall in no way constitute state approval or accreditation of any institution and shall not be used in any form of advertising by any institution.

B. Licensed institutions may use the state name and licensing agency as follows:

1. (*Name of Institution*) is currently licensed by the Board of Regents of the State of Louisiana. Licenses are renewed by the State Board of Regents every two years. Licensed institutions have met minimal operational standards set forth by the state, but licensure does not constitute accreditation, guarantee the transferability of credit, nor signify that programs are certifiable by any professional agency or organization.

2. Any licensed institution wishing to use the state name and licensing agency in any promotion or advertising is restricted to the language which appears above. The statement must appear in its entirety and any modifications are not permissible under these rules or the law.

3. Advertising shall not include false or misleading statements with respect to the institution, its personnel, courses, or services, or the occupational opportunities of its graduates.

4. Institutions claiming accreditation by agencies not recognized by the United States Department of Education must clearly state in all advertising and promotional literature that the institutions' accreditation is not recognized by either the United States Department of Education or the State of Louisiana.

¹Neither the institution nor its agents shall engage in false advertising or other misleading practices.

AUTHORITY NOTE: Promulgated in accordance with R.S. 17:1808.

HISTORICAL NOTE: Promulgated by the Department of Education, Board of Regents, LR 19: (December 1993).

§323. Hearings and Appeals

A. Institutional hearings and appeals are handled in accordance with guidelines set forth in R.S. 17:1808, §1(E)(F).

AUTHORITY NOTE: Promulgated in accordance with R.S. 17:1808.

HISTORICAL NOTE: Promulgated by the Department of Education, Board of Regents, LR 19: (December 1993).

Chapter 5. Consumer Protection

§501. General Provisions

A. Individuals must make reasonable effort to solve disputes directly with the institution. If a solution cannot be reached, an individual may file a written complaint with the Board of Regents. Board of Regents' staff will review the facts and intervene where appropriate. Such intervention shall not include legal action on behalf of the party, but may include additional investigation of the institution including a site visit to determine if the institution's license should be revoked.

B. Disciplinary Provisions and Administrative Penalties

1. The Board of Regents may institute disciplinary proceedings against a licensed agent who engages in false or misleading advertising. The Board of Regents may also

require an institution to submit all advertising for approval prior to use.

2. It is illegal for institutions which come under the jurisdiction of the Board of Regents to advertise, recruit students for, and/or operate educational programs in the state of Louisiana unless properly registered and licensed.

3. Penalties may be assessed for the following violations:
- a. operating an institution without a license;
 - b. deceptive or fraudulent advertising;
 - c. offering an unapproved program;
 - d. other violations as determined by the Board of Regents.

4. Violations may result in suspension of student enrollments where patterns of abuse and willful misconduct have been established.

C. Meetings, Site Visits, and Reports

1. The Board of Regents, at its discretion, may conduct preliminary conferences with institutional officers and board members to discuss standards and procedures for implementing licensure.

2. The Board of Regents may require a site visit and examiner's report at the cost of the institution. The cost shall not exceed the actual dollar amount incurred by the Board of Regents.

3. Site visits could include an inspection of facilities, books, school files and records, as well as interviews with administrators, faculty, and students.

4. Examiners would submit a report following the site visit with recommendations pertaining to the licensure of the institution.

D. Enforcement

1. The attorney general is authorized to seek injunctive relief against an institution operating in noncompliance with the law. All costs incurred by the state of Louisiana in connection with such action shall be borne by the institution if it is found to be operating illegally.

AUTHORITY NOTE: Promulgated in accordance with R.S. 17:1808.

HISTORICAL NOTE: Promulgated by the Department of Education, Board of Regents, LR 19: (December 1993).

Sammie W. Cosper
Commissioner of Higher Education

RULE

**Department of Education
Proprietary School Commission**

**Annual Licensure Renewal Fee
(PSC-12, Appendix L) (LAC 28:III)**

In accordance with R.S. 49:950 et seq., the Administrative Procedure Act, the Department of Education has amended the Annual Licensure Renewal Fee (PSC-12, Appendix L) in Bulletin 1443.

**Title 28
EDUCATION**

**Part III. Proprietary Schools
Annual License Renewal Fee Based on School's Previous
Year Gross Tuition Revenue
PSC-12**

APPENDIX L

**Annual Licensure Renewal Fee
Based on School's Previous Year
Gross Tuition Revenue
(R.S. 17:3141.4B)
State of Louisiana
Department of Education
Proprietary School Commission
Post Office Box 94064
Baton Rouge, Louisiana 70804-9064**

The annual renewal fee for licensed schools shall be based upon each school's previous year gross tuition revenue as follows:

Gross Tuition	Fee
Under \$50,000	\$500
\$50,000 and up	Greater of \$1,000 or .25% of gross tuition income

Please Attach:

(1) This completed PSC-12 form attesting to the gross tuition income of the school.

(2) For those schools which participate in Title IV funding, a set of financial statements that have been audited by a certified public accountant including a current balance sheet and an income statement showing gross tuition receipts for the school's last fiscal year and in the case of a corporation, signed by an officer of the corporation OR in the case of a sole proprietorship or partnership, signed by the owner(s) or a duly authorized agent acting on behalf of the owner(s). Or, for those schools which do not participate in Title IV funding, a set of financial statements that have been reviewed by a certified public accountant, including a current balance sheet and an income statement showing gross tuition receipts for the school's last fiscal year, and in the case of a corporation, signed by an officer of the corporation OR in the case of a sole proprietorship or partnership, signed by the owner(s) or a duly authorized agent acting on behalf of the owner(s).

Affidavit

Know All Men by These Presents:

That we, _____
of the City of _____ State of _____
collected gross tuition in our previous business year (12-month

period) from (date) _____ to _____ of
\$ _____.

I do solemnly declare and affirm, under penalties of perjury
that the information presented on this document is true and
correct.

Signature: _____

Title: _____

Name of Institution: _____

Address: _____

Notary Public

Signature and Seal

Attach a set of reviewed and/or audited financial statements
from your CPA including a current balance sheet and an
income statement for your school's last fiscal year.

AUTHORITY NOTE: Promulgated in accordance with R.S.
17:3141.3, 3141.8, 3141.14, 3141.18.

HISTORICAL NOTE: Promulgated by the Department of
Education, Proprietary School Commission, LR 16:603 (July 1990),
amended LR 19: 173 (February 1993), LR 19: (December 1993).

Andrew H. Gasperecz
Executive Secretary

RULE

**Department of Education
Proprietary School Commission**

**Initial Licensure Fee and Annual License
Renewal Fee Schedule (LAC 28:III)**

In accordance with R.S. 49:950 et seq., the Administrative
Procedure Act, the Department of Education has amended the
initial licensure fee and annual license renewal fee schedule in
Bulletin 1443.

**Title 28
EDUCATION**

**Part III. Proprietary Schools
Initial License Fee and Annual License Renewal Fee
Schedule**

The initial license fee shall be \$2,000 and the annual
renewal fee shall be based upon each school's previous year's
gross tuition revenues as follows:

Under 50,000	\$500
\$50,000 and up	Greater of \$1,000 or .25 percent of gross tuition income
* * *	

AUTHORITY NOTE: Promulgated in accordance with R.S.
17:3141.3, 3141.8, 3141.14, 3141.18

HISTORICAL NOTE: Promulgated by the Department of
Education, Proprietary School Commission, LR 16:604 (July 1990),
amended LR 19:173 (February 1993), LR 19: (December 1993).

Andrew H. Gasperecz
Executive Director

RULE

**Department of Education
Proprietary School Commission**

Student Protection Fund Claim Form (LAC 28:III)

In accordance with R.S. 49:950 et seq., the Administrative
Procedure Act, the Department of Education has adopted the
following the Student Protection Fund Claim Form (PSC-16,
Appendix P).

WERE YOU ABLE TO COMPLETE THE COURSE OF STUDY PRIOR TO THE SCHOOL'S CLOSURE?

Yes _____ No _____

WERE YOU OFFERED AN OPPORTUNITY TO COMPLETE THE COURSE AT ANOTHER SCHOOL THAT WAS LOCATED A REASONABLE COMMUTING DISTANCE FROM THE CLOSED SCHOOL?

Yes _____ No _____

DID YOU ACCEPT THE TEACH-OUT OPTION? Yes _____ No _____

If no, explain: _____

IF A TEACH-OUT WAS OFFERED, WERE ANY ADDITIONAL COSTS INVOLVED?

Yes _____ No _____

If yes, explain: _____

WERE YOU ABLE TO TRANSFER THE CREDITS YOU EARNED FROM THE CLOSED SCHOOL TO ANOTHER SCHOOL WHICH OFFERED SIMILAR COURSES?

Yes _____ No _____

DID YOU RECEIVE A REFUND OR A DISCHARGE OF YOUR LOAN FROM ANY OTHER SOURCE SUCH AS THE SCHOOL OR ANOTHER TUITION RECOVERY PROGRAM? IF SO, HOW MUCH? _____ . WHAT WAS THE SOURCE OF THE REFUND? _____

PLEASE PROVIDE THE FOLLOWING INFORMATION WITH YOUR CLAIM FORM:

- a. copy of enrollment agreement;
- b. copies of canceled checks and or receipts if education was financed by student or parent;
- c. copies of documentation from lender showing amounts owed; and
- d. any documentation you feel will assist this office in assessing your claim.

COOPERATION AGREEMENT: As part of the consideration for the repayment of my loan under the Student Protection Fund, I hereby agree to cooperate with the Proprietary School Commission and the Louisiana Student Financial Assistance Commission in any enforcement action regarding collection of the loan at the closed school which I previously attended.

This cooperation means that I agree to testify about any information I provided to support the repayment of my loan; and that I agree to produce any documentation which was and/or is available to me in regard to the information I provided to support the repayment of my loan, including the execution of any affidavits which may be required with respect to the information.

By filing a claim against the Student Protection Fund under this Section, the claimant hereby relinquishes any right he or she may have against the owner or school for reimbursement of tuition, in favor of the State Board of Elementary and Secondary Education.

CLAIMANT

SOCIAL SECURITY NUMBER

DATE

AUTHORITY NOTE: Promulgated in accordance with R.S. 17:3141.3, 3141.8, 3141.14, 3141.18.

HISTORICAL NOTE: Promulgated by the Department of Education, Proprietary School Commission, LR 19: (December 1993).

Andrew H. Gasperecz
Executive Director

RULE

Department of Education Proprietary School Commission

Student Protection Fund Policies (LAC 28:III)

In accordance with R.S. 49:950 et seq., the Administrative Procedure Act, the Department of Education has adopted the following rule to amend Bulletin 1443 by adopting policies and procedures regarding the Student Protection Fund.

Title 28

EDUCATION

Part III. Proprietary Schools

Student Protection Fund Policies

Introduction

A. Public Law 102-325 enacted July 23, 1992, reauthorized Higher Education Act. The Program Integrity Provisions, Part H, Subpart 3 discuss Eligibility and Certification Procedures for a participating institution, effective on and after October 1, 1992. Under Part H, the Financial Responsibility Standards (§498 (c) (5) (A)) provide that the secretary of the U.S. Department of Education shall: establish requirements for the maintenance by an institution of higher education of sufficient cash reserves to ensure repayment of any required refunds.

B. The law provides that the secretary shall exempt an institution of higher education from the cash reserve requirements if he determines that:

1. the institution is located in a state that has a tuition recovery fund that ensures that there are sufficient cash reserves to ensure repayment of any required refunds;
2. that the institution contributes to the fund; and
3. the institution otherwise has legal authority to operate within the state.

C. In Louisiana the three exemption provisions will be met by the previously established Proprietary School Student Protection Fund and program.

D. The tuition recovery fund operations will comply with provisions of R.S. 17:3141.16-18.

Student Protection Fund Policy

A. The Student Protection Fund is administered by the Louisiana Board of Elementary and Secondary Education, Advisory Commission on Proprietary Schools and shall be subjected to audit and review by the Office of the Legislative Auditor.

B. Required refunds due from the Student Protection Fund will be provided on a pro rata basis.

C. The administrator of the Student Protection Fund will enter into an agreement with the state guaranty agency that any refunds will be allocated in the following preferential order:

1. present holder of the loan, whether lender or LASFAC; and

2. any remaining balance to the borrower.

D. Administration of the Student Protection Fund is subject to review by the U.S. Department of Education and the state guaranty agency.

1. The Proprietary Schools Bureau shall retain all records pertaining to the determination of payment or denial of refunds for a period of not less than one year after final determination has been made.

2. Records shall be maintained in an organized manner.

3. Records shall be readily accessible by USDE and guarantee agency auditors.

Student Protection Fund Procedures

A. An application for tuition recovery, in the form of a student affidavit, may be submitted after reasonable efforts to compensate the student when the following resources have been exhausted:

1. provide teachout;

2. acquire refund from the school;

3. acquire refund from surety bond required by R.S. 17:3141.5 (D);

4. acquire refund from any other school resources; and

5. acquire refund from USDE, Closed Schools Section.

B. As required by U.S. Department of Education, Dear Colleague 93-L-153, the affidavit will provide the borrower's name, social security number, address, the closed school's name and address, the borrower's educational program and, to the best of the borrower's knowledge, the dates of enrollment at the closed school. The affidavit will also include certifications that the borrower:

1. was enrolled and in attendance at the closed school on the date it closed and had not graduated or completed the course of study;

2. was unable to complete the course of study in which he/she was enrolled because of the school's closure;

3. was not offered an opportunity to complete the remainder of the course of study at another school that was located at a reasonable commuting distance from the closed school;

4. was unable to obtain credit towards a degree, certificate or diploma that the borrower could transfer to another school that offered courses similar to those offered by the closed school; and

5. did not receive a refund from any other source, such as any federal tuition recovery program or a discharge of the loan obligation under any federal closed-school provisions.

C. Lenders holding loans eligible for refunds under the Student Protection Fund may submit the claim to the Proprietary School Commission without undertaking any additional collection activity.

D. The pro rata refund will be for outstanding balances on Federal Stafford subsidized, Federal Stafford unsubsidized, Federal SLS, and Federal PLUS loans, in accordance with U.S. Department of Education, Dear Colleague Gen-92-21,

page 88, for periods of enrollment on or after July 1, 1993.

E. Refund calculations will be based upon copies of enrollment contracts, student ledger cards, and other pertinent documents submitted by the student.

F. Students applying for relief to the Student Protection Fund will be notified of the determination within 60 days of receipt of the application by the Louisiana Proprietary School Bureau.

AUTHORITY NOTE: Promulgated in accordance with R.S. 17:3141.3, 3141.8, 3141.14, 3141.18.

HISTORICAL NOTE: Promulgated by the Department of Education, Proprietary School Commission, LR 19: (December 1993).

Andrew H. Gasperez
Executive Secretary

RULE

Department of Education Proprietary School Commission

Surety Bond Claim Form (LAC 28:III)

In accordance with R.S. 49:950 et seq., the Administrative Procedure Act, the Department of Education, Proprietary School Commission has adopted the following Surety Bond Claim Form (PSC-15, Appendix O).

PLEASE PROVIDE THE FOLLOWING INFORMATION WITH YOUR CLAIM FORM:

- a. copy of enrollment agreement;
- b. copies of canceled checks and or receipts if education was financed by student or parent;
- c. copies of documentation from lender showing amounts owed; and
- d. any documentation you feel will assist this office in assessing your claim.

By filing a claim against the Surety Bond under this Section, the claimant hereby relinquishes any right he or she may have against the owner or school for reimbursement of tuition, in favor of the State Board of Elementary and Secondary Education.

CLAIMANT

SOCIAL SECURITY NUMBER

AUTHORITY NOTE: Promulgated in accordance with R.S. 17:3141.3, 3141.8, 3141.14, 3141.18.

HISTORICAL NOTE: Promulgated by the Department of Education, Proprietary School Commission, LR 19: (December 1993).

Andrew H. Gasperecz
Executive Secretary

RULE

**Student Financial Assistance Commission
Office of Student Financial Assistance**

Late Guarantee (LAC 28:V)

The Louisiana Student Financial Assistance Commission will permit issue of a loan guarantee after the last day of the loan period or last day of attendance as at least a half-time student. Policy 6.1.8 A is being revised as follows:

6.1.8 Guarantee and Duration of Guarantee Commitment

A. LASFAC will guarantee the loan of any applicant who, to the satisfaction of LASFAC, meets the eligibility criteria outlined in this manual. Provided that the school certifies the loan application during the period of enrollment, LASFAC will issue a loan guarantee after the last day of the loan period or after the borrower's last day of attendance as at least a half-time student if the disbursement will meet the late disbursement policy defined in Section 6.2.12 of this manual. Such authorized late guarantee and disbursement may be entered on LOSFA's automated system without documentation for up to 30 days after the last day of the loan period or after the borrower's last day of attendance as at least a half-time student. The Request for Late Disbursement form, documenting the reason for the late guarantee will be required and must be submitted to LASFAC for loans guaranteed from day 31 to day 60 after the end of the loan period or of at least half-time attendance.

* * *

Jack L. Guinn
Executive Director

RULE

**Student Financial Assistance Commission
Office of Student Financial Assistance**

**LEO Alternative Employer Repayment
(LAC 28:V)**

The Louisiana Student Financial Assistance Commission hereby amends the Louisiana Employment Opportunity (LEO) Loan Program Policy and Procedure Manual to provide a procedure to reestablish repayment after the borrower has left the employ of the original employer prior to completion of repaying the loan. Section 4.2.8 will be added to the manual as follows:

4.2.8 How Lender Will Conduct Due Diligence in Establishing and Processing LEO Repayment when Borrower has Terminated Employment with Program Employer

A. Holder reestablishes the terms of LEO loan borrower's repayment:

1. When notified by the borrower, LASFAC or the prior employer that the trainee has terminated employment at the borrowers option, or has accepted employment with another company:

a. use LASFAC's policy regarding repayment terms; and

b. determine the remaining amount owed and remaining repayment period available;

c. the lender shall forbear and accrue interest through the revised first payment due date.

2. If notified late, within 30 days after being notified, the lender shall:

a. use LASFAC's policy regarding repayment terms; and

b. mail a properly completed repayment schedule to the borrower. The first payment due date must fall not less than 15, nor more than 30 days from the date the lender mails the repayment schedule;

c. document the file as indicated in 4.2.7 A 2 b, c and d.

3. Retain a copy of the repayment schedule sent to the borrower.

B. If contacted by the borrower to renegotiate the terms of his repayment, do so only:

1. if the lender wishes to renegotiate; and

2. within LASFAC's policy regarding repayment terms.

C. If the lender wishes to grant a forbearance while the borrower is in repayment status do so within LASFAC's policies and procedures for granting forbearance under Paragraph 5.3.

D. If the borrower becomes delinquent while in repayment status, handle the delinquency in accordance with instruction on How to Pursue a Delinquent Borrower, Paragraph 7.2.1.

E. When the borrower pays his LEO loan in full, handle in accordance with instructions 4.2.7 E 1-3.

F. A holder shall not use the rule of 78's to calculate the outstanding principal balance of a loan.

Jack L. Guinn
Executive Director

RULE

**Student Financial Assistance Commission
Office of Student Financial Assistance**

Tuition Award Funding Procedure (LAC 28:V)

The Louisiana Student Financial Assistance Commission, Office of Student Financial Assistance, hereby amends the Scholarship/Grant Policy and Procedure Manual by adding Subparagraph B.3 to Chapter IX (Funding and Charges).

B. ...

3. In the event insufficient funds are appropriated to fully reimburse institutions for tuition awards for all students determined eligible to participate in the Louisiana Honors Scholarship program for a given academic year, funding shall be allocated in the following priority:

a. Should the amount appropriated be insufficient to fully fund continuing awards, the total amount available shall be distributed to institutions for continuing students based on the same percentage of tuition for each student. No reimbursement will be made for tuition awards for newly eligible students.

b. Should the amount appropriated exceed the amount needed to fully fund continuing awards, institutions shall be reimbursed for 100 percent of student tuition for continuing students. After funding continuing students, remaining funds shall be prorated to institutions for new awardees based on the same percentage of tuition for each awardee.

c. Individual awards to first-time eligible students will not be made if the amount prorated is insufficient to award at least 10 percent of the students' tuition.

d. The percentage of tuition to be reimbursed will be calculated based on:

i. each school's reported annual average tuition;

ii. the actual number of students (continuing or new, whichever is applicable) who are determined eligible for the current academic year at each school.

Jack L. Guinn
Executive Director

RULE

Department of Environmental Quality Office of Air Quality and Radiation Protection Air Quality Division

Filling of Gasoline Storage Vessels; Control of Emissions from the Chemical Woodpulp Industry (LAC 33:III.2131, 2301) (AQ79)

Under the authority of the Environmental Quality Act, particularly R.S. 30:2054 et seq., and in accordance with the provisions of the Administrative Procedure Act, R.S. 49:950 et seq., the secretary has amended the Air Quality Division Regulations, LAC 33: III.2131 and 2301, (AQ79).

This change to an existing rule, §2131, is to include the prohibition of any transfer of gasoline to be caused or allowed by any person. The change in §2301 conforms with LAC 33:III.3533.A.4, Standards of Performance for Kraft Pulp Mills (Subpart BB) and Federal Rule 40 CFR 60.238.

Title 33

ENVIRONMENTAL QUALITY

Part III. Air

Chapter 21. Control of Emission of Organic Compounds §2131. Filling of Gasoline Storage Vessels

A. Control Requirement. No person shall cause or allow the transfer of gasoline from any delivery vessel into any stationary storage container unless such container is equipped with a submerged fill pipe and unless the displaced vapor emissions from submerged filling of the container are processed by a vapor recovery system which reduces such emissions by at least 90 percent.

* * *

AUTHORITY NOTE: Promulgated in accordance with R.S. 30:2054.

HISTORICAL NOTE: Promulgated by the Department of Environmental Quality, Office of Air Quality and Nuclear Energy, Air Quality Division, LR 13:741 (December 1987), amended LR 16:609 (July 1990), amended by the Office of Air Quality and Radiation Protection, Air Quality Division, LR 17:654 (July 1991), LR 18:1122 (October 1992), LR 19: (December 1993).

Chapter 23. Control of Emissions for Specific Industries¹

Subchapter A—Chemical Woodpulp Industry §2301. Control of Emissions from the Chemical Woodpulp Industry

* * *

D. Emissions Limitations. No person shall cause, suffer, allow or permit emissions to the atmosphere in excess of the limitations stated in this Subchapter. Notwithstanding the specific limits set forth in this Subchapter, in order to maintain the lowest possible emission of air contaminants, the highest and best practicable treatment and control currently available shall be provided in every case of new construction and/or modernization.

* * *

3. Total Reduced Sulfur Emissions. Emissions of Total Reduced Sulfur (TRS) from existing sources specified below shall not exceed the following limits:

* * *

f. smelt dissolving tanks, .016 grams per kilogram black liquor solids fired. Compliance with the particulate emission limits of LAC 33:III.2301.D.1.b. by a scrubbing device employing fresh water as the scrubbing medium make up will be accepted as evidence of adequate TRS control on smelt dissolving tanks. Emission limits are given in terms of 12-hour averages. For recovery furnaces, one percent, and for lime kilns, two percent of all 12-hour TRS averages per quarter year above the specified level, under conditions of proper operation and maintenance, in the absence of start-ups, shutdowns and malfunctions, are not considered to be violations of the emission limitation. These are not running averages, but are instead for discrete contiguous 12-hour periods of time;

* * *

¹Regulation of Emissions of Volatile Organic Compounds for Certain Industries are presented in Chapter 21.

AUTHORITY NOTE: Promulgated in accordance with R.S. 30:2054.

HISTORICAL NOTE: Promulgated by the Department of Environmental Quality, Office of Air Quality and Nuclear Energy, Air Quality Division, LR 13:741 (December 1987), amended by the Department of Environmental Quality, Office of Air Quality and Radiation Protection, Air Quality Division, LR 19: (December 1993).

James B. Thompson, III
Assistant Secretary

RULE

Department of Environmental Quality Office of Air Quality and Radiation Protection Radiation Protection Division

Fee System of the Air Quality Control Program (LAC 33:III.223) (AQ77) (Originally proposed as §6523)

Under the authority of the Environmental Quality Act, particularly R.S. 30:2014 et seq., and in accordance with the provisions of the Administrative Procedure Act, R.S. 49:950 et seq., the secretary has amended the Air Quality and Radiation Protection Regulations, LAC 33:III.223 (AQ77).

The rule, LAC 33:III.223, corrects technical errors created during the initial promulgation of the rule pertaining to asbestos.

Title 33

ENVIRONMENTAL QUALITY

Part III. Air

Chapter 2. Rules and Regulations for the Fee System of the Air Quality Control Programs (Originally proposed as Chapter 65)

§223. Fee Schedule Listing

* * *

ADDITIONAL PERMIT FEES AND ADVF FEES		
Fee Number	Fee Description	Amount
	* * *	
2020	The Issuance of an Asbestos Demolition Verification Form (ADVF) - (at least 10 working days notification given)	50.00
2030	The Issuance of an Asbestos Demolition Verification Form (ADVF) - (less than 10 working days notification given)	75.00
2040	Agent Accreditation: Includes Contractor/Supervisor, Inspector, Management Planner, or Project Designer - Normal Processing (greater than 3 working days after receipt of required documentation and fees)	200.00
2050	Agent Accreditation: Includes Contractor/Supervisor, Inspector, Management Planner, or Project Designer - Emergency Processing (less than or equal to 3 working days after receipt of required documentation and fees)	300.00
2060	Worker Accreditation - Normal Processing (greater than 3 working days after receipt of required documentation and fees)	50.00
2070	Worker Accreditation - Emergency Processing (less than or equal to 3 working days after receipt of required documentation and fees)	75.00
	* * *	
2090	Training Organization Recognition Plus Trainer Recognition Per Trainer - Normal Processing (greater than 3 working days after receipt of required documentation and fees)	300.00 50.00
2100	Training Organization Recognition Plus Trainer Recognition Per Trainer - Emergency Processing (less than or equal to 3 working days after receipt of required documentation and fees)	450.00 75.00
	* * *	

AUTHORITY NOTE: Promulgated in accordance with R.S. 30:2054.

HISTORICAL NOTE: Promulgated by the Department of Environmental Quality, Office of Air Quality and Nuclear Energy, Air Quality Division, LR 13:741 (December 1987), amended LR 14:613 (September 1988), LR 15:735 (September 1989), amended by the Office of Air Quality and Radiation Protection, Air Quality Division, LR 17:1205 (December 1991), repromulgated LR 18:31 (January 1992), amended LR 18:706 (July 1992), LR 18:1256 (November 1992), LR 19: (December 1993).

James B. Thompson, III
Assistant Secretary

RULE

Office of the Governor Office of Veterans Affairs

State Aid Program (LAC 4:VII.917)

The Louisiana Department of Veterans Affairs has amended LAC 4:VII.917.B and E, Eligibility Requirements for the State Aid Program.

LAC 4:VII.917.B has been revised to remove specific wartime dates to read wartime period as defined by R.S. 29:251.2, so that the dates of any future declared war(s) will automatically be included and would not have to be accomplished through legislative action. By amending this rule, same would be in line with state law.

LAC 4:VII.917.E has been revised to add the word "immediately", which puts this rule in conformity with state law.

Title 4

ADMINISTRATION

Part VII. Governor's Office

Chapter 9. Veterans Affairs

Subchapter B. State Aid Program

§917. Eligibility

* * *

B. A member of the armed forces of the United States of America must have been killed in action or died in active service from other causes or who is missing in action or who is a prisoner of war or veteran who died as a result of a service-connected disability incurred during a wartime period defined in R.S. 29:251.2.

* * *

E. The 100 percent service-connected veteran must have been a resident of Louisiana for at least two years immediately preceding admission of the child into a training institution.

* * *

AUTHORITY NOTE: Promulgated in accordance with R.S. 29:253.

HISTORICAL NOTE: Promulgated by the Office of the Governor, Department of Veterans Affairs, LR 7:485 (October 1981), amended LR 13:743 (December 1987), LR 19: (December 1993).

Ernie P. Broussard
Executive Director

RULE

Office of the Governor Patient's Compensation Fund Oversight Board

Future Medical Care and Related Benefits (LAC 37:III.Chapter 19)

The Patient's Compensation Fund Oversight Board, under authority of the Louisiana Medical Malpractice Act, R.S. 40:1299.41 et seq., and in accordance with the Administrative Procedure Act, R.S. 49:950 et seq., hereby adopts LAC 37:III.Chapter 19, as follows, which provides for and governs the administration and payment by the Fund of future medical care and related benefits for patients.

Title 37

INSURANCE

Part III. Patient's Compensation Oversight Board Chapter 19. Future Medical Care and Related Benefits §1901. Scope of Chapter

A. The rules of the Chapter provide for and govern the administration and payment by the fund of future medical care and related benefits for patients deemed to be in need of future care and related benefits pursuant to a final judgment issued by a court of competent jurisdiction or agreed to in a settlement reached between a patient and the fund.

B. The rules of the Chapter shall be applicable to all malpractice claims.

AUTHORITY NOTE: Promulgated in accordance with R.S. 40:1299.44D.(3).

HISTORICAL NOTE: Promulgated by the Office of the Governor, Patient's Compensation Fund Oversight Board, LR 19: (December 1993).

§1903. Definition

For purposes of this Chapter, "future medical care and related benefits" means all reasonable medical, surgical, hospitalization, physical rehabilitation, and custodial services, and includes drugs, prosthetic devices and other similar materials reasonably necessary in the provision of such services. "Future medical care and related benefits" shall not mean non-essential specialty items or devices of convenience.

AUTHORITY NOTE: Promulgated in accordance with R.S. 40:1299.44D.(3).

HISTORICAL NOTE: Promulgated by the Office of the Governor, Patient's Compensation Fund Oversight Board, LR 19: (December 1993).

§1905. Obligation of the Fund

A. The fund shall provide and/or fund the cost of all future medical care and related benefits, after the date of the accident and continuing as long as medical or surgical attention is reasonably necessary, that are made necessary by the health care provider's malpractice, pursuant to a final judgment issued by a court of competent jurisdiction or as agreed to in a settlement reached between a patient and the fund, unless the patient refuses to allow the future medical care and related benefits to be furnished.

B. The fund acknowledges that a court is required neither to choose the best medical treatment nor the most cost-efficient treatment for a patient. The intent of this Chapter is to distinguish between those devices which are reasonably

necessary to a patient's treatment and those which are devices of convenience or non-essential specialty items for a patient.

C. Pursuant to the Act, the board has been, expressly and/or implicitly, vested with the responsibility and authority for the management, administration, operation and defense of the fund and, as a prudent administrator, it must insure that all future medical care costs and related benefits are reasonable and commensurate with the usual and customary costs of such care in the patient's community.

D. Payments for future medical care and related benefits shall be paid by the fund without regard to the \$500,000 limitation imposed in R.S. 40:1299.42.

AUTHORITY NOTE: Promulgated in accordance with R.S. 40:1299.44D.(3).

HISTORICAL NOTE: Promulgated by the Office of the Governor, Patient's Compensation Fund Oversight Board, LR 19: (December 1993).

§1907. Claims for Future Medical Care and Related Benefits

A. A patient, who is deemed to be in need of future medical care and related benefits pursuant to a final judgment issued by a court of competent jurisdiction or as agreed to in a settlement reached between the patient and the fund, may make a claim to the fund through the board for future medical care and related benefits made necessary by the health care provider's malpractice.

B. If a patient's claim for future medical care and related benefits is extremely complex or is disputed, then the fund may refer the matter to medical or other experts or to its counsel for review or litigation.

AUTHORITY NOTE: Promulgated in accordance with R.S. 40:1299.44D.(3).

HISTORICAL NOTE: Promulgated by the Office of the Governor, Patient's Compensation Fund Oversight Board, LR 19: (December 1993).

§1909. Attorneys; Medical Experts; Architects; Adjusters

A.1. An attorney chosen to represent the fund pursuant to §1907 shall be an independent contractor of the state of Louisiana, shall meet all applicable requirements for an outside contractor retained by the state of Louisiana, and shall be chosen by the Assistant Commissioner for Risk or his designee. The attorney shall be licensed to practice law in the state of Louisiana.

2. Once a matter involving future medical care and related benefits is referred to an attorney pursuant to §1907, then the attorney shall be responsible for the matter to the extent of the assignment (i.e. investigation and/or litigation of a particular claim, issue or request). The attorney shall issue status reports to the claims supervisor at least every 90 days until the matter is concluded.

3. The attorney chosen to represent the fund pursuant to §1907 may recommend any and all possible remedies to the fund, including litigation of any kind, and may hire or retain experts, subject to prior approval by the fund. The attorney shall utilize legal staff, including paralegals, nurse/paramedical personnel, clerks and investigators, where necessary. With prior approval from the claims supervisor, the attorney may appoint a case manager in cases where no case manager has been appointed.

B. Pursuant to §1907, medical experts may be retained directly by the fund for evaluation, diagnosis or, with patient consent or by court order, for treatment of the patient. All medical experts retained by the fund shall be licensed or otherwise certified by the state of Louisiana. However, consulting physicians, licensed to practice in states other than Louisiana, may be retained by the fund only if they are board-certified in the applicable area of specialty.

C. Pursuant to §1907, architects with special expertise in medical facility design, contractors and other building trade experts may be retained directly by the fund in future medical care cases involving issues of residential modifications or renovations. Architects retained by the fund shall be licensed by the state of Louisiana. Contractors retained by the fund shall be licensed or certified as general contractors by the state of Louisiana. Architects and contractors retained by the fund shall also possess experience in the design and construction of medical facility and/or "barrier free" residences.

D. Pursuant to §1907 and subject to fund approval, adjusters may be retained as independent contractors on the recommendation of the claims manager or of the attorney chosen to represent the fund pursuant to §1907.

AUTHORITY NOTE: Promulgated in accordance with R.S. 40:1299.44D.(3).

HISTORICAL NOTE: Promulgated by the Office of the Governor, Patient's Compensation Fund Oversight Board, LR 19: (December 1993).

§1911. Examinations; Notice Requirements

A. The fund shall be entitled to have a patient submit to a physical or mental examination, by a health care provider of the fund's choice, from time to time to determine the patient's continued need of future medical care and related benefits, subject to the following requirements:

1. Notice in writing shall be delivered to or served upon the patient or the patient's counsel of record, specifying the time and place where the examination will be conducted. Delivery of the notice may be by certified mail or by hand delivery. Such notice shall be given at least 10 days prior to the time stated in the notice.

2. The place at which the examination is to be conducted shall not involve an unreasonable amount of travel for the patient, considering all of the circumstances.

3. It shall not be necessary for a patient who resides outside of Louisiana to come to this state for an examination unless so ordered by the court.

4. The examination shall be conducted by a health care provider licensed by the state of Louisiana or by the state wherein the patient resides.

B. Examinations may not be required by the fund more frequently than at six-month intervals except that, upon application to the court having jurisdiction of the claim and for reasonable cause shown therefor, examinations within a shorter interval may be ordered.

C. Within 30 days after the examination, the patient shall be compensated, by the party requesting the examination, for all necessary and reasonable expenses incidental to submitting to the examination, including the reasonable costs of travel, meals, lodging or other direct expenses.

D. The patient shall be entitled to have a health care provider or an attorney of his choice, or both, present at the

examination. The patient shall pay such health care provider or attorney himself.

E. The patient shall be promptly furnished with a copy of the report of the examination made by the health care provider conducting the examination on behalf of the fund.

AUTHORITY NOTE: Promulgated in accordance with R.S. 40:1299.44D.(3).

HISTORICAL NOTE: Promulgated by the Office of the Governor, Patient's Compensation Fund Oversight Board, LR 19: (December 1993).

§1913. Choice of Health Care Provider

A patient entitled to future medical care and related benefits, as determined under this Chapter, shall be entitled to evaluation, diagnosis and treatment by the health care providers of the patient's choice; provided, however, that the health care provider rendering such evaluation, diagnosis or treatment shall be licensed to practice medicine in Louisiana or by the state in which the patient resides.

AUTHORITY NOTE: Promulgated in accordance with R.S. 40:1299.44D.(3).

HISTORICAL NOTE: Promulgated by the Office of the Governor, Patient's Compensation Fund Oversight Board, LR 19: (December 1993).

§1915. Psychological/Psychiatric Treatment and Counseling

The fund will provide and/or fund psychiatric/psychological testing, evaluation, diagnosis and treatment of a patient entitled to future medical care and related benefits, as determined under this Chapter, where these medical services are reasonable and are made necessary by the health care provider's malpractice.

AUTHORITY NOTE: Promulgated in accordance with R.S. 40:1299.44D.(3).

HISTORICAL NOTE: Promulgated by the Office of the Governor, Patient's Compensation Fund Oversight Board, LR 19: (December 1993).

§1917. Nursing Care; Sitter Care

A. The fund will provide and/or fund inpatient or outpatient nursing or sitter care when such care is required to provide reasonable medical, surgical, hospitalization, physical rehabilitation, or custodial services made necessary by the health care provider's malpractice, subject to the following limitations:

1. All nursing or sitter care shall be specifically prescribed or ordered by a patient's treating health care provider.

2. All nursing or sitter care shall be rendered by a licensed and/or qualified registered nurse or licensed practical nurse or by a sitter, a member of the patient's family or household, or other person as specifically approved by the fund.

3. There shall be a presumption that the person rendering nursing or sitter care is qualified if the treating health care provider issues a statement that that person is competent and qualified to render the nursing or sitter care required by the patient.

4. All claims for nursing or sitter care payments must include a signed, detailed statement by the person rendering nursing or sitter care, setting forth the date, time and type of care rendered to and for the patient.

B. Providers of nursing or sitter care shall be funded at the usual and customary rate charged by similarly licensed or qualified health care providers in a patient's home state, city or town. However, nursing or sitter care provided by members of the patient's family or household will be funded at a rate not to exceed \$6 per hour regardless of the licensure or qualification of the provider.

C. The fund shall be entitled to periodic inspections or assessments of the physical environment in which the nursing or sitter care is being rendered. The fund may seek a judicial ruling to discontinue the payments for future medical care and related benefits if, upon inspection and recommendation of a licensed or qualified health care provider, it is determined that the physical environment in which the nursing or sitter care is being rendered is inadequate or inappropriate and not in the best interest of the patient.

D. The fund may seek a judicial ruling to discontinue the payments for future medical care and related benefits if, upon a physical or mental examination of the patient, pursuant to §1911, and recommendation of a licensed or qualified health care provider, it is determined that the nursing or sitter care being rendered is inadequate or inappropriate and not in the best interest of the patient.

AUTHORITY NOTE: Promulgated in accordance with R.S. 40:1299.44D.(3).

HISTORICAL NOTE: Promulgated by the Office of the Governor, Patient's Compensation Fund Oversight Board, LR 19: (December 1993).

§1919. Treatment Protocol

In cases where the future medical needs of the patient are so great that multi-disciplinary, long-term acute care is needed by the patient, and the patient and/or the patient's family, tutor, legal guardian or caregivers are deemed to be incapable of determining what treatment is necessary, then the fund may obtain or develop a treatment protocol for the patient. The patient will be provided with a copy of the written treatment protocol and will be asked to consent to the treatment or course of treatment proposed by the protocol prior to implementation of the protocol.

AUTHORITY NOTE: Promulgated in accordance with R.S. 40:1299.44D.(3).

HISTORICAL NOTE: Promulgated by the Office of the Governor, Patient's Compensation Fund Oversight Board, LR 19: (December 1993).

§1921. Vehicles

A. The fund will provide and/or fund the cost of standard-modified vehicles or specialized-modified vehicles to patients entitled to receive future medical care and related benefits under this Section, when ownership and use of such vehicles are reasonably necessary in providing reasonable medical, surgical, hospitalization, physical rehabilitation, or custodial services made necessary by the health care provider's malpractice. The vehicles described herein are standard model, modified passenger vehicles of domestic manufacture or standard model, modified vans of domestic manufacture. Alternatively, and at the fund's option, the fund will provide and/or fund modifications to the patient's vehicle when such modifications are reasonably necessary in the provision of such services.

B. The choice of vehicle, vendor of the vehicle, modifications thereto and inclusion or exclusion of option items on these vehicles will be at the sole discretion of the fund.

C. The fund will not provide nor fund the cost of any type of insurance for any such vehicle and will not provide nor fund the maintenance or operating costs on any vehicle modified by the fund or provided by the fund.

AUTHORITY NOTE: Promulgated in accordance with R.S. 40:1299.44D.(3).

HISTORICAL NOTE: Promulgated by the Office of the Governor, Patient's Compensation Fund Oversight Board, LR 19: (December 1993).

§1923. Ancillary Cost; Mileage

A. The fund will reimburse a patient (or the patient's family or caregivers) entitled to future medical care and related benefits under this Section for actual out-of-pocket ancillary costs of medical treatment and/or care to the patient, including but not limited to the actual costs of over-the-counter medicines and patient aids, the reasonable costs of hotel-motel accommodations and meals associated with physician appointments or treatment, when such costs are made necessary by the health care provider's malpractice.

B. The fund will reimburse a patient (or the patient's family or caregivers) entitled to future medical care and related benefits under this Section for actual mileage to and from physician appointments or treatment at a rate not to exceed \$.24 per mile or the current mileage rate allowance under applicable state guidelines.

C. The level of expense reimbursement pursuant to this Section shall not exceed the maximum allowable expenses under applicable state guidelines set for in the Travel Regulations, P.P.M. 49, Louisiana Register, Vol. 16, No. 7, p. 582.

D. Patients shall provide actual receipts or signed statements verifying the reasonable mileage for odometer readings to receive reimbursements pursuant to this Section. Expenses for hotel/motel accommodations and meals associated with physician appointments or treatment shall not be reimbursed without prior approval by the fund.

AUTHORITY NOTE: Promulgated in accordance with R.S. 40:1299.44D.(3).

HISTORICAL NOTE: Promulgated by the Office of the Governor, Patient's Compensation Fund Oversight Board, LR 19: (December 1993).

§1925. Modifications/Renovations to Patient's Residence

A. The fund will provide and/or fund the cost of modifications to a patient's residence which are reasonably necessary in providing reasonable medical, physical rehabilitation and custodial services for the patient and which are made necessary by the health care provider's malpractice. The fund will not provide nor fund the cost of devices of convenience.

B. The patient may be required to submit to a medical examination by a medical expert selected by the fund to specifically determine the patient's needs as they relate to the home. Upon completion and receipt of the medical expert's report, the patient and/or the patient's family or caregivers will then be consulted by the case manager to determine specifically what modifications should be made to the

home. The case manager, the fund's claims' supervisor, the claims' manager, the attorney for the fund, if one is selected, and the architect chosen by the fund will then review the report(s) of the medical expert(s) and the case manager, and then meet to determine what action will be taken as to the modifications of the home, within the specific guidelines listed below:

1. The fund will provide and/or fund the cost of modifications or renovations to the patient's existing home, including, but not limited to modifications of lavatories, including handicap accessible toilets, showers, ramps for ingress and egress, expanded doorways and expansion of rooms to accommodate medical devices required by the patient, which are reasonably necessary for the care and rehabilitation of the patient.

2. All renovations and/or modifications will be designed and built with "builders spec" or similar grade materials from plans drawn and/or approved by an architect obtained by the fund.

3. When the fund has provided and/or funded modifications or renovations to the home where the patient resides, the fund shall retain no interest in that residence. Where the home is owned by the patient's parents, relatives, caregivers or guardian, the fund reserves the right to require the owners of the home to execute a promissory note, mortgage or other instrument of security in favor of the patient in an amount equal to the increased value of the home as determined by a qualified appraiser retained by the fund.

AUTHORITY NOTE: Promulgated in accordance with R.S. 40:1299.44D.(3).

HISTORICAL NOTE: Promulgated by the Office of the Governor, Patient's Compensation Fund Oversight Board, LR 19: (December 1993).

§1927. Testimony; Communications

A. Any health care provider selected and paid by the fund who shall make or be present at an examination of the patient conducted pursuant to §1911 may be required to testify as to the conduct thereof and the findings so made.

B. Communications made by the patient during the examination conducted pursuant to §1911 by the health care provider shall not be considered privileged.

AUTHORITY NOTE: Promulgated in accordance with R.S. 40:1299.44D.(3).

HISTORICAL NOTE: Promulgated by the Office of the Governor, Patient's Compensation Fund Oversight Board, LR 19: (December 1993).

§1929. Fees and Costs

The fund shall pay all reasonable fees and costs of examinations, including the costs and fees of expert witnesses in any proceeding, where termination of medical care and related benefits is sought.

AUTHORITY NOTE: Promulgated in accordance with R.S. 40:1299.44D.(3).

HISTORICAL NOTE: Promulgated by the Office of the Governor, Patient's Compensation Fund Oversight Board, LR 19: (December 1993).

§1931. Attorney Fees

A. Pursuant to its continuing jurisdiction, the district court, from which a final judgment has been issued in cases where future medical care and related benefits have been determined

to be needed by a patient, shall award reasonable attorney fees to the patient's attorney if the court finds that the fund unreasonably failed to pay for medical care and related benefits within 30 days after submission of a claim for payment of such benefits.

B. A patient and/or the patient's attorney shall not be entitled to attorney fees in any action to enforce rights pursuant to Subsection A of this Section if the patient fails or refuses to submit to examination in accordance with a notice and if the requirements of §1911 have been satisfied.

AUTHORITY NOTE: Promulgated in accordance with R.S. 40:1299.44D.(3).

HISTORICAL NOTE: Promulgated by the Office of the Governor, Patient's Compensation Fund Oversight Board, LR 19: (December 1993).

Suanne Grosskopf
Executive Director

RULE

Department of Health and Hospitals Board of Licensed Professional Vocational Rehabilitation Counselors

License, Practice, License Renewal, Definitions and
Reciprocity (LAC 46:LXXXVI.503,703,705 and 707)

The Department of Health and Hospitals, Licensed Professional Vocational Rehabilitation Counselors Board of Examiners, under authority of the Rehabilitation Counselor Licensing Act, R.S. 37:3441-3452 of the 1988 Legislature and R.S. 36:259(E)(21), and in accordance with the Administrative Procedure Act R.S. 49:950 et seq., has adopted LAC 46:LXXXVI.707 and has amended LAC 46:LXXXVI.503, 703, and 705 governing the practice of rehabilitation counseling.

Title 46

PROFESSIONAL AND OCCUPATIONAL STANDARDS

Part LXXXVI. Licensed Professional Vocational Rehabilitation Counselors Board of Examiners

Chapter 5. License and Practice of Vocational Rehabilitation Counseling

§503. Definitions

* * *

C. *Practice of Rehabilitation Counseling*—rendering or offering to individuals, groups, organizations, or the general public rehabilitation services in private practice for compensation involving the application of principles, methods, or procedures of the rehabilitation counseling profession which include but are not limited to:

* * *

3. *Vocational Rehabilitation Services*—which includes, but is not limited to, vocational assessment, vocational counseling, education, and training services, including on-the-job training, self-employment plans, and job placement. For purposes of

this Chapter, "vocational assessment" includes, but is not limited to, the administration, interpretation, and use of single scale screening tests of intelligence and tests of education, achievement, personal traits, interests, aptitudes, abilities, language, adaptive behavioral tests and symptom screening checklist, solely to define vocational goals and plan actions as related to rehabilitation concerns, educational progress, and occupations and careers.

* * *

AUTHORITY NOTE: Promulgated in accordance with R.S. 37:3443.

HISTORICAL NOTE: Promulgated by the Department of Social Services, Licensed Professional Vocational Rehabilitation Counselors Board of Examiners, LR 15:277 (April 1989), amended by the Department of Health and Hospitals, Licensed Professional Vocational Rehabilitation Counselors Board of Examiners, LR 19: (December 1993).

Chapter 7. Requirements for Licensure and Renewal of License

§703. Requirements

* * *

D. has declared special competencies and demonstrated professional competence by successfully passing the Certified Rehabilitation Counselor Examination offered by the Commission on Rehabilitation Counselor Certification, and forwarding such documentation to the board. As an alternative to the CRC Exam, the LRC Board of Examiners has instituted an exam to be administered to all applicants beginning after July 1, 1993, who have completed procedural and eligibility requirements. The exam is to be administered by the board of examiners at least twice each year. Those sitting for the exam will be required to pass the exam with a score determined by the board of examiners.

E. has received a Master's Degree in Rehabilitation Counseling or related field and two years of experience under the direct supervision of a licensed vocational rehabilitation counselor or a Bachelor's degree in Vocational Rehabilitation or related field and five years of work experience, working under the direct supervision of a licensed vocational rehabilitation counselor. An applicant may subtract one year of the required professional experience for successfully completing Ph.D. requirements in a rehabilitation counseling program acceptable to the Board. However, in no case, may the applicant have less than one year of the required professional experience.

1. Supervision Requirements. Rehabilitation counselors who employ or supervise other professionals or students will facilitate professional development of such individuals. They provide appropriate working conditions, timely evaluations, constructive consultation, and experience opportunities.

a. *Supervision* is defined as assisting the provisionally licensed counselor in developing expertise in methods of the professional counseling practice and in developing self-appraisal and professional development strategies. Supervision must comply with standards as set by the board. Exact details of supervision are contained in the "Supervisory Work Experience Plan" package published by and available through the LRC Board of Examiners office.

i. The board recommends one hour of supervision for every week of direct client contact as outlined. Supervision may not take place via mail, telephone, fax, computer, or video. This type of contact with supervisor may be counted under consultation; however, it cannot replace face-to-face supervisions as defined.

b. Acceptable modes for supervision of direct clinical contact are the following:

i. Individual Supervision: The supervisory session is conducted by an approved supervisor with one provisionally licensed counselor present.

ii. Group Supervision: The supervisory session is conducted by an approved supervisor with no more than two provisionally licensed counselors present.

iii. The LRC supervisor as opposed to the work supervisor may supervise no more than two persons at any one time unless the supervisor has no other caseload responsibilities, in which case he/she may supervise up to three counselors.

c. Most of the provisionally licensed counselor's direct contact with clients must be supervised by an approved supervisor or supervisors as defined below:

i. At least 2/3 of supervision time must be individual supervision as defined above. The remaining 1/3 may be either individual supervision or group supervision as defined above.

d. The counseling activities of the provisionally licensed counselor must be performed pursuant to the supervisor's order, control, oversight, guidance and full professional responsibility. The supervisor must read and co-sign all written reports including formal reports and progress reports prepared by the provisionally licensed counselor. The provisionally licensed counselor will remain under the full professional responsibility and supervision of the supervisor until he/she is fully licensed.

e. The process of supervision must encompass multiple strategies of supervision, including regularly scheduled live observation of counseling sessions. The process may also include discussion of the provisionally licensed counselor's self-reports, microtraining, interpersonal process recall, modeling, role-playing, and other supervisory techniques.

f. The supervisor must provide nurturance and support to the provisionally licensed counselor explaining the relationship of theory to practice, suggesting specific actions, assisting the provisionally licensed counselor in exploring various models for practice, and challenging discrepancies in the provisionally licensed counselor's practice.

g. The supervisor must ensure the provisionally licensed counselor familiarity with important literature in the field of rehabilitation.

h. The supervisor must provide training appropriate to the provisionally licensed counselor's intended area of expertise and practice.

i. The supervisor must model effective professional rehabilitation counseling practice.

j. The supervisor must ensure that the vocational rehabilitation counseling and the supervision of the vocational rehabilitation provisionally licensed counselor is completed in an appropriate professional setting.

k. The supervisor and the provisionally licensed counselor must share a similar area of specialty. Also:

- i. the provisionally licensed counselor must also have received a letter of supervision approval from the board;
- ii. the professional setting cannot include private practice in which the provisionally licensed counselor operates or manages;
- iii. Supervisors may employ provisionally licensed counselors in their private practice setting. The supervisor may bill clients for services rendered by the provisionally licensed counselor, however, under no circumstances can the provisionally licensed counselor bill clients directly for services rendered by him/herself.

1. The supervisor must certify to the board that the provisionally licensed counselor has successfully complied with all requirements for supervised counseling experience.

2. Qualifications of a Supervisor

a. Those individuals who may provide supervision to provisionally licensed counselors must meet the following requirements:

i. **Licensure Requirements.** The supervisor must hold a Louisiana license as a Licensed Vocational Rehabilitation Counselor.

ii. **Rehabilitation Counseling Practice.** The supervisor must have been in practice in his/her field for at least five years.

iii. **Training in Supervision.** Supervisors must have successfully completed either (a) or (b) below:

(a). **Graduate-Level Academic Training.** At least one graduate-level academic course in counseling supervision. The course must have included at least 45 clock hours (equivalent to a three-credit hour semester course) of supervision training.

(b). **Professional Training.** A board-approved and sponsored professional training program in supervision is required. The training program must be established by the board and meet presentation standards established by the board. All LRCs choosing to become supervisors must complete supervisor training by January 1, 1995. The first training session will be held October 21, 1993, at the LRA/LARP Professional meeting in New Orleans. The board will conduct additional training sessions each year in other areas of the state at a nominal fee.

iv. One year of documented experience in the supervision of vocational rehabilitation case material.

b. A supervisor may not be a relative of the provisionally licensed counselor. Relative of the provisionally licensed counselor is defined as spouse, parent, child, sibling of the whole- or half-blood, grandparent, grandchild, aunt, uncle, one who is or has been related by marriage or has any other dual relationship.

c. No person shall serve as a supervisor if his/her license is expired or subject to terms of probation, suspension, or revocation.

3. Responsibility of Applicant Under Supervision

a. During the period of supervised counseling experience an applicant will identify him/herself as a provisionally licensed counselor.

b. Each provisionally licensed counselor must provide

his/her clients with a disclosure statement that includes:

- i. his/her training status; and
- ii. the name of his/her supervisor for licensure purposes.

c. A provisionally licensed counselor must comply with all laws and regulations related to the practice of vocational rehabilitation counseling.

d. A provisionally licensed counselor may not initiate a private practice during their period of supervised counseling experience. Provisionally licensed counselors who are employed within their supervisors' private practice setting cannot, under any circumstances, bill clients directly for services they render.

e. Upon completion of the required supervised counseling experience, the provisionally licensed counselor needs to submit an application form for licensure. Any individual who does not apply for licensure within three months after completing the required supervised rehabilitation counseling experience cannot continue to practice professional vocational rehabilitation counseling.

4. **Registration of Supervised Experience.** Beginning January 1, 1994, all proposed supervision arrangements must be approved by the board prior to the starting date of the supervised experience.

a. The provisionally licensed counselor will:

i. along with his/her supervisor provide the board with a written proposal outlining with as much specificity as possible the nature of the counseling duties to be performed by the provisionally licensed counselor and the nature of the supervision;

ii. submit this written proposal on forms provided by the board at least 60 days prior to the proposed starting date of the supervision;

iii. submit along with the written proposal the appropriate fee determined by the board.

b. Supervised experience rendered by the provisionally licensed counselor in an exempt setting needs to meet the requirements in this rule if that supervised experience is to meet the requirements for licensure.

c. Following the board's review, the provisionally licensed counselor will be informed by letter either that the proposed supervision arrangement has been approved or that it has been rejected. Any rejection letter will outline, with as much specificity as practicable, the reasons for rejection.

AUTHORITY NOTE: Promulgated in accordance with R.S. 37:3447.

HISTORICAL NOTE: Promulgated by the Department of Social Services, Licensed Professional Vocational Rehabilitation Counselors Board of Examiners, LR 15:277 (April 1989), amended by the Department of Health and Hospitals, Licensed Professional Vocational Rehabilitation Counselors Board of Examiners, LR 19: (December 1993).

§705. Renewal

A. A licensed professional vocational rehabilitation counselor shall renew his license by paying the renewal fee every year prior to August 1st, and by meeting the requirement that 30 clock hours of continuing education be obtained during a two-year period in an area of professional rehabilitation counseling as approved by CRC or by the board. The chairman shall issue a document renewing the

license for a term of one year. Beginning August 1, 1994, all LRCs will begin a new two year period for clock hours. Anyone licensed during the year out of sync with the LRC Board fiscal year will be required to acquire a pro rata share of hours as determined by the board for their first two year period. All LRCs will be required to renew every year with their training hours acquired over a two year period. Renewal must be completed within 60 days of the August 1 deadline for each renewal year. If the renewal is not submitted within that time frame, the license shall lapse, and the applicant must meet all existing licensure requirements to become an LRC.

B. A licensed professional vocational rehabilitation counselor may request retirement status if he is not going to engage in private practice for the next year or longer. Under retirement status the counselor would not be required to submit continuing education credits. If a retiree wishes to reactivate, he would need to do the following:

1. notify board;
2. complete application for reactivation;
3. pay existing renewal fee;
4. begin documentation of continuing education hours.

C. A retiree cannot practice with a retirement status license. If the retiree holds a retirement status license for longer than five years and requests reactivation, he must pass the exam or show qualified continuing education hours for the previous two years.

AUTHORITY NOTE: Promulgated in accordance with R.S. 37:3447.

HISTORICAL NOTE: Promulgated by the Department of Social Services, Licensed Professional Vocational Rehabilitation Counselors Board of Examiners, LR 15:277 (April 1989), amended by the Department of Health and Hospitals, Licensed Professional Vocational Rehabilitation Counselors Board of Examiners, LR 19: (December 1993).

§707. Reciprocity

The LRC Board of Examiners will license anyone who furnishes evidence that they have been licensed by another state in vocational rehabilitation counseling, not the generic licensed professional counseling. The board of examiners will make the determination based on evidence from another state's law and from the counselor's application, thus allowing said applicant to become licensed based on proof of good standing from reciprocating state's Vocational Rehabilitation Counselors Board of Examiners, having filed an application, paid existing established fees and without sitting for the exam if there is proof that the applicant sat for the reciprocating state's exam or waiver of said exam.

AUTHORITY NOTE: Promulgated in accordance with R.S. 37:3447.

HISTORICAL NOTE: Promulgated by the Department of Health and Hospitals, Licensed Professional Vocational Rehabilitation Counselors Board of Examiners, LR 19: (December 1993).

Larry S. Stokes
Chairman

RULE

Department of Health and Hospitals Board of Nursing

Licensure by Examination/Endorsement; Temporary Permits
(LAC 46:XLVII.3349, 3351, 3353)

Notice is hereby given that the Department of Health and Hospitals, Board of Nursing, under the authority of R.S. 37:918(K), and in accord with R.S. 49:950 et seq., has amended LAC 46:XLVII.3349, 3351 and 3353 as follows:

Title 46

PROFESSIONAL AND OCCUPATIONAL STANDARDS

Part XLVII. Nurses

Subpart 2. Registered Nurses

Chapter 33. General Rules

Subchapter D. Registration and Licensure

§3349. Licensure by Examination

A. In order to be licensed as a registered nurse in Louisiana, all registered nurse applicants shall take and pass the National Council Licensure Examination for Registered Nurses (NCLEX-RN).

1. The licensing examination (NCLEX-RN) shall be authorized by the Board of Nursing in accordance with the contract between the board and the National Council of State Boards of Nursing, Inc.

2. Each examination shall be given under the direction of the executive director of the board or another designee of the board.

3. Individual results from the examination shall be released to individual candidates and to the director of their nursing education program. Aggregate results are published for statistical purposes.

B. Requirements for eligibility to take the NCLEX-RN in Louisiana include:

1. completion of a nursing education program approved by the Board of Nursing in the state in which the school is located.

* * *

5. freedom from restrictions by any health regulatory board of any state.

* * *

AUTHORITY NOTE: Promulgated in accordance with R.S. 37:918, 920 and 921.

HISTORICAL NOTE: Promulgated by the Department of Health and Human Resources, Board of Nursing, LR 7:77 (March 1981), amended LR 11:348 (April 1985), amended by the Department of Health and Hospitals, Board of Nursing, LR 19: (December 1993).

§3351. Licensure by Endorsement

* * *

B.2. The applicant is not under restriction of any form by any health regulatory board in any state.

* * *

AUTHORITY NOTE: Promulgated in accordance with R.S. 37:918, 920 and 921.

HISTORICAL NOTE: Promulgated by the Department of Health and Human Resources, Board of Nursing, LR 7:77 (March 1981),

amended by the Department of Health and Hospitals, Board of Nursing, LR 19: (December 1993).

§3353. Temporary Permits

A. In accordance with R.S. 37:920, the Board of Nursing may issue the following temporary permits to practice as a registered nurse:

1. A working permit may be issued to graduates of approved schools pending the results of the first licensing examination, provided the examination is taken within three months after graduation from the approved nursing education program.

* * *

B.3. There be no record of conviction or pending charge of felonious crime. If information relative to conviction of a felonious crime, or an investigation of same, is received during the 90-day permit interval, the permit will be recalled.

4. There is no allegation of cause for denial of licensure according to R.S. 37:921. If information relative to a cause for denial of licensure, or an investigation of same, is received during the 90-day permit interval, the permit shall be recalled.

* * *

AUTHORITY NOTE: Promulgated in accordance with R.S. 37:918, 920 and 921.

HISTORICAL NOTE: Promulgated by the Department of Health and Human Resources, Board of Nursing, LR 7:78 (March 1981), amended by the Department of Health and Hospitals, Board of Nursing, LR 19: (December 1993).

Barbara L. Morvant., R. N., M. N.
Executive Director

RULE

Department of Health and Hospitals Board of Optometry Examiners

Continuing Education; License to Practice
(LAC 46:LI.503)

Act No. 202 of the 1993 Regular Session of the Louisiana Legislature amended portions of Chapter 12 of Title 37 of the Revised Statutes (R.S. 37:1041 et seq.) to expand the scope of optometric practice by authorizing optometrists to obtain certification to treat abnormal conditions and pathology of the human eye and its adnexa, including employment of therapeutic pharmaceutical agents. The legislation directed the Board of Optometry Examiners to adopt rules implementing the Act. In accordance with the authority set forth in R.S. 37:1048, notice is hereby given that the Department of Health and Hospitals, Board of Optometry Examiners has amended LAC 46:LI.301, regarding continuing education and LAC 46:LI.503.G, regarding use of diagnostic drugs.

LAC 46:LI.301 amends the continuing education requirements set forth in Act No. 202 of the 1993 Louisiana Legislature for optometrists who receive certification to treat diseases and to use and prescribe pharmaceuticals. No

changes are made to the existing rules applicable to non-therapeutically certified optometrists.

LAC 46:LI.503.G amends the requirements for certification for use of therapeutic privileges. The existing rule regarding certification for the use of drugs for diagnostic purposes is readopted as Paragraph 1 without substantive change. Paragraph 2 is added to §503.G and sets forth the certification requirements for optometrists wishing to treat eye abnormalities and diseases, including required refresher courses if the prerequisite education was taken during certain periods as set forth in the rules.

Title 46

PROFESSIONAL AND OCCUPATIONAL STANDARDS

Part LI. Optometrists

Chapter 3. License

§301. Continuing Education

Each licensed optometrist shall comply with the following continuing education requirements:

A. Standard optometry certificate holders and diagnostic pharmaceutical certificate holders shall complete between January 1 and December 31 of each calendar year at least 12 classroom hours of continuing education courses approved by the Louisiana State Board of Optometry Examiners.

B. Certificate holders authorized to treat pathology and use and prescribe therapeutic pharmaceutical agents shall complete between January 1 and December 31 of each calendar year at least 16 classroom hours of continuing education courses approved by the Louisiana State Board of Optometry Examiners, of which at least eight classroom hours shall consist of matters related to ocular and systemic pharmacology and current diagnosis and treatment of ocular disease. Such certificate holders will be entitled to apply the CPR continuing education to their required annual continuing education, provided that such CPR continuing education shall not count towards the required eight classroom hours related to ocular and systemic pharmacology and current diagnosis and treatment of ocular disease, and provided further that no more than four hours of CPR continuing education may be applied to the continuing education requirement in any two calendar year period.

C. Written evidence of satisfaction of continuing education requirement for the prior calendar year shall be submitted on or before the first day of March of each year.

AUTHORITY NOTE: Promulgated in accordance with R.S. 37:1048 and R.S. 37:1051.

HISTORICAL NOTE: Adopted by the Department of Health and Human Resources, Board of Optometry Examiners, 1970, amended and promulgated by the Department of Health and Hospitals, Board of Optometry Examiners, LR 19: (December 1993).

Chapter 5. Practicing Optometry

§503. License to Practice Optometry

* * *

G. Certification to Use Diagnostic and Therapeutic Drugs and to Treat Ocular Pathology. An optometrist may be certified to use ocular diagnostic and therapeutic pharmaceutical agents and to treat ocular pathology. In order to obtain such certification, an optometrist shall comply with the following requirements:

1. Certification to Use Diagnostic Drugs

a. In order to be approved as an optometrist authorized to use diagnostic drugs, as set forth in Act 123 of the 1975 Session of the Louisiana Legislature, an optometrist shall present to the secretary of the Louisiana State Board of Optometry Examiners for approval by the board, the following:

i. evidence that the applicant is a licensed Louisiana optometrist, holding a current license in compliance with all license renewal requirements of the Louisiana Optometry Practice Act for the year in which he applies for certification;

ii. transcript credits, in writing, evidencing that the applicant has completed a minimum of five university semester hours in pharmacology from an accredited university or college of optometry, subsequent to December 31, 1971. The pharmacology hours shall consist of a minimum of two hours in general pharmacology and a minimum of three hours in ocular pharmacology.

b. Upon submission of the above, the secretary shall present same to the board for approval at the next regular meeting. Upon approval by the board, the secretary shall cause to be issued to the optometrist a certificate indicating compliance with the legislative requirement and intent.

c. The certificate issued by the secretary shall be over the secretary's signature and bear a number identical to the number on the license originally issued by the board to the optometrist.

2. Certification to Treat Ocular Pathology and to Use and Prescribe Therapeutic Pharmaceutical Agents

a. Definitions. For purposes of this Paragraph 2 the following definitions shall apply:

Application Date—the date the board receives in its office by certified mail return receipt requested an application for certification under this Paragraph 2.

Approved Educational Institution—an educational institution providing education in optometry that is approved by the board and is accredited by a regional or professional accrediting organization which is recognized or approved by the Council of Post-secondary Accreditation of the United States Department of Education.

Board—the Louisiana State Board of Optometry Examiners.

TMOD—Treatment and Management of Ocular Disease test administered by the International Association of Boards of Optometry.

b. Requirements for Certification. In order to obtain certification under this Paragraph 2, an optometrist shall present to the secretary of the Louisiana State Board of Optometry Examiners for approval by the board:

i. a certified transcript from an approved educational institution evidencing satisfaction of the educational prerequisites for certification to use diagnostic pharmaceutical agents as set forth in LAC 46:LI.503.G.1.a.ii or evidence of current certification by the board for the use of diagnostic pharmaceutical agents under LAC 46:LI.503.G.1; and

ii. certification from the American Heart Association or the American Red Cross evidencing current qualification to perform cardiopulmonary resuscitation (CPR). The certification must show completion of the basic CPR course or

re-certification within six months of the application date in order to be considered "current"; and

iii. a signed statement from the applicant stating that he or she possesses operable and unexpired child and adult automatic epinephrine injector kits in every office location in which the applicant practices; and

iv. a certified transcript from an approved educational institution evidencing satisfactory completion after January 1, 1985 of 46 clock hours of classroom education and 34 clock hours of supervised clinical training which are equivalent to at least five semester hours of postgraduate education in the examination, diagnosis and treatment of abnormal conditions and pathology of the human eye and its adnexa. The board shall obtain such written certification as it deems appropriate to satisfy itself that the courses reflected on the transcript satisfy the statutory course requirements set forth in R.S. 37:1051(C). Inability of the board to obtain satisfactory written certification as set forth in the preceding sentence shall result in rejection of the optometrist's application under this Section; and

(a). if the applicant's transcript reflects graduation from an accredited school of optometry or completion of the required five semester hours in the examination, diagnosis, and treatment of abnormal conditions and pathology of the human eye and adnexa, between January 1, 1989 and December 31, 1992, the applicant shall also provide written evidence of satisfactorily completing, within the previous year of the application date, at least 12 clock hours of board approved update training in recent ocular and systemic pharmacology and current diagnosis and treatment of ocular disease; or

(b). if the applicant's transcript reflects graduation from an accredited school of optometry or completion of the required five semester hours in the examination, diagnosis, and treatment of abnormal conditions and pathology of the human eye and adnexa, between January 1, 1985 and December 31, 1988, the applicant shall also provide written evidence of satisfactorily completing, within the previous year of the application date, at least 20 clock hours of board approved update training in recent ocular and systemic pharmacology and current diagnosis and treatment of ocular disease; or

v. in lieu of the requirements of LAC 46:LI.503.G.2.b.iv above, written proof of having passed the TMOD and a certified transcript from an approved educational institution evidencing successful completion of 34 clock hours of supervised clinical training after January 1, 1985 which are equivalent to at least two semester hours of postgraduate clinical education in the examination, diagnosis and treatment of abnormal conditions and pathology of the human eye and its adnexa.

3. Certificates. The board will provide each optometrist certified under the provisions of this Subsection with a certificate bearing the original optometric license number followed by a therapeutic certification number.

AUTHORITY NOTE: Promulgated in accordance with R.S. 37:1048 and R.S. 37:1051.

HISTORICAL NOTE: Adopted by the Department of Health and Human Resources, Board of Optometry Examiners, September 1975,

promulgated LR 1:463 (October 1975); amended by the Department of Health and Human Resources, Board of Optometry Examiners, LR 13:241 (April 1987), amended by the Department of Health and Hospitals, Board of Optometry Examiners, LR 19: (December 1993).

Chesley Gregory, O.D.
President

RULE

Department of Health and Hospitals Office of Public Health

Authorization of Testing of a New Method for Identifying Congenital Syphilis in Newborns

In accordance with the provisions of the Administrative Procedure Act, R.S. 49:950 et seq., the Department of Health and Hospitals, Office of Public Health has adopted a rule to authorize a pilot program to identify congenital syphilis in newborns using a new method of testing.

This rule authorizes the utilization of heelstick screening and a new laboratory test to detect syphilis at birth rather than traditional methods. A study in northwest Louisiana is being conducted during 1993 and has been funded by a \$50,000 grant for study.

This rule further authorizes that the basic guidelines of the program include procedures for screening and notifying mothers and delivering physicians of positive results and for confidentiality of information. Additionally, the project is authorized to include data gathering and analysis of the validity of test results under the heelstick testing, compared to traditional methods.

Rose Forrest
Secretary

RULE

Department of Health and Hospitals Office of Public Health

Death Certificate Preparation (LAC 48:V.12307)

In accordance with the Administrative Procedure Act, as amended, the Department of Health and Hospitals, Office of Public Health is amending the following pursuant to R.S. 49:950, et seq. to amend instructions for preparing a Louisiana Certificate of Death by supplanting LAC 48:V.12307 in its entirety with the following. Promulgation of the rule is authorized by R.S. 40:33C.

Title 48 PUBLIC HEALTH - GENERAL Part V. Preventive Health Services Subpart 45. Vital Records

Chapter 123. Preparation of Certificates

§12307. Preparation of Certificate of Death (PHS 16)

A. Section—Personal Data of Deceased

1. Last Name of Decedent (Item 1A). Enter the legal surname of the deceased. If unknown, enter "Unknown." Generation identifications, e.g., Jr., II, III, etc., shall appear immediately following and as a part of the surname. The surname of a married woman may be either her maiden name or that of her husband. Alias or "also known as" names should be entered immediately below the legal name in parenthesis (for example, AKA-Smith).

2. First Name (Item 1B). Enter the first name of the deceased. If unknown, enter "Unknown." Alias or "also known as" names should be entered immediately below the legal name in parenthesis (for example, AKA-John).

3. Middle Name (Item 1C). Enter the second name of the deceased. If unknown, enter "Unknown." Alias or "also known as" names should be entered immediately below the legal name in parenthesis (for example, AKA-George). If there is no middle name, enter "none."

4.a. Date of Death (Item 2A). Enter the month, day and year using the following abbreviations: Jan., Feb., Mar., Apr., Aug., Sept., Oct., Nov., and Dec. Enter the complete spelling for the months of May, June and July.

b. Consider a death at midnight to have occurred at the end of one day rather than the beginning of the next. For instance, the date for a death that occurs at midnight on December 31 should be recorded as December 31.

c. If the exact date of death is unknown, it should be estimated by the person completing the medical certification. "Est." should be placed before the date.

5. Hour of Death (Item 2B). Enter the hour of death indicating a.m. or p.m. If the institution operates on 24-hour or military time, the hour of death may be so expressed. If the exact hour of death is unknown, it should be estimated by the person completing the medical certification. "Est." should be placed before the hour.

6. Sex (Item 3). Enter male or female. Do not abbreviate or use other symbols. If sex cannot be determined after verification with medical records, inspection of the body or other sources, enter "unknown." Do not leave this item blank.

7. Race (Item 4)

a. Enter the race of the decedent as stated by the informant.

b. For Asians and Pacific Islanders, enter the national origin of the decedent, such as Chinese, Japanese, Korean, Filipino, or Hawaiian.

c. If the informant indicates that the decedent was of mixed race, enter both races or ancestries. Generic designations of Oriental, Polynesian, European, etc., are not acceptable.

8. Marital Status (Item 5). Enter married, never married, widowed or divorced. "Single" is not an acceptable entry.

9. Surviving Spouse (Item 6). If the decedent was legally married at death, enter the name (maiden name in the case of a widow) of the survivor. If the deceased was single at death, enter "None."

10. Date of Birth (Item 7). Enter the exact month, day, and year that the decedent was born. Enter the date using the following abbreviations: Jan., Feb., Mar., Apr., Aug., Sept., Oct., Nov., and Dec. Enter the complete spelling for the months of May, June and July. If the birth date is an estimation, enter the birth date as "est." then the date. If the birth date is unknown, enter "Unknown."

11. Age in Years (Item 8A). Enter the decedent's exact age in years at his or her last birthday. If the decedent was under one year of age, leave blank.

12. Under One Year (Item 8B)

a. Enter the exact age in either months or days at time of death for infants surviving at least one month.

b. If the infant was 1-11 months of age inclusive, enter the age in completed months.

c. If the infant was less than one month old, enter the age in completed days.

d. If the infant was over one year or under one day of age, leave blank.

13. Under One Day (Item 8C)

a. Enter the exact number of hours and/or minutes the infant lived for infants who did not survive an entire day.

b. If the infant lived 1-23 hours inclusive, enter the age in completed hours.

c. If the infant was less than one hour old, enter the age in minutes.

14. Birthplace (Item 9)

a. If the decedent was born in the United States, enter the name of the city or location and state.

b. If the decedent was not born in the United States, enter the name of the location and country of birth whether or not the decedent was a U.S. citizen at the time of death.

c. If the decedent was born in the United States but the city or location is unknown, enter the name of the state only. If the state is unknown, enter "U.S.—unknown."

d. If the decedent was born in a foreign country but the city or location is unknown, enter the name of the country.

e. If the decedent was born in a foreign country but the country is unknown, enter "Foreign-unknown."

f. If no information is available regarding place of birth, enter "Unknown."

15. Usual Occupation (Item 10)

a. Enter the usual occupation of the decedent. This is not necessarily the last occupation of the decedent. "Usual occupation" is the kind of work the decedent did during most of his or her working life, such as claim adjuster, farmhand, coal miner, janitor, store manager, college professor, or civil engineer. Never enter "retired."

b. If the decedent was a homemaker at the time of death but had worked outside the household during his or her working life, enter that occupation. If the decedent was a "homemaker" during most of his or her working life, and never worked outside the household, enter "homemaker."

c. Enter "student" if the decedent was a student at the time of death and was never regularly employed or employed

full time during his or her working life. If none of the above are applicable, enter "not applicable" or "NA."

16. Kind of Business/Industry (Item 11)

a. Enter the kind of business or industry to which the occupation listed in Item 10 is related, such as insurance, farming, coal mining, hardware store, retail clothing, university, or government. Do not enter firm or organization names.

b. If the decedent was a homemaker during his or her working life, and "homemaker" is entered as the decedent's usual occupation in Item 10, enter "own home" or "someone else's home," whichever is appropriate.

c. If the decedent was a student at the time of death and "student" is entered as the decedent's usual occupation in item 10, enter the type of school, such as high school or college, in item 11. If none of the above are applicable, enter "not applicable" or "NA."

17. Of Hispanic Origin? (Item 12)

a. Check "No" or "Yes." If "yes" is checked, enter the specific Hispanic group. Item 12 should be checked on all certificates. Do not leave this item blank. The entry in this item should reflect the response of the informant.

b. For the purposes of this item, "Hispanic" refers to people whose origins are from Spain, Mexico, or the Spanish-speaking countries of Central or South America. Origin can be viewed as the ancestry, nationality, lineage, or country in which the person or his or her ancestors were born before their arrival in the United States.

c. There is no set rule as to how many generations are to be taken into account in determining Hispanic origin. A person's Hispanic origin may be reported based on the country of origin of a parent, a grandparent, or some far-removed ancestor. The response should reflect what the decedent considered himself or herself to be and should not be based on percentages of ancestry.

d. If the decedent was a child, the parent(s) should determine the Hispanic origin based on their own origin. Although the prompts include the major Hispanic groups of Cuban, Mexican, and Puerto Rican, other Hispanic groups may also be identified in the space provided.

e. If the informant reports that the decedent was of multiple Hispanic origin, enter the origins as reported (for example, Mexican-Puerto Rican).

f. If an informant identifies the decedent as Mexican-American or Cuban-American, enter the Hispanic origin as stated.

g. This item is not a part of the race item. A decedent of Hispanic origin may be of any race. Each question, race and Hispanic origin, should be asked independently.

18. Ever in U.S. Armed Forces (Item 13). Enter yes or no in the blank.

19. Social Security Number (Item 14). Enter the Social Security Number of the decedent. If it is unknown, enter "unknown."

20. Decedent's Education (Item 15)

a. Elementary/Secondary (0-12)—College (1-4 or 5+)

b. Enter the highest number of years of regular schooling completed by the decedent in either the space for elementary/secondary school or the space for college. An

entry should be made in only one of the spaces. The other space should be left blank. Report only those years of school that were completed. A person who enrolls in college but does not complete one full year should not be identified with any college education in this item.

c. Count formal schooling. Do not include beauty, barber, trade, business, technical, or other special schools when determining the highest grade completed.

B. Section—Place of Death

1. Place of Death (Item 16A). Check appropriate box.

2. Name of Facility (Item 16B).

a. Hospital or Facility Deaths

i. If the death occurred in a hospital or other facility, enter the full name of the hospital or facility.

ii. If death occurred en route to or on arrival at a hospital, enter the full name of the hospital. Deaths that occur in an ambulance or emergency vehicle en route to a hospital are in this category.

b. Non-hospital or Non-facility Deaths

i. If the death occurred at home, enter the house number and street name.

ii. If the death occurred at some place other than those described above, enter the number and street name of the place.

iii. If the death occurred on a moving conveyance, enter the name of the vessel, for example, "S.S. Emerald Seas (at sea)" or "Eastern Airlines Flight 296 (in flight)."

3. Place of Death in City Limits? (Item 16C). Enter "yes" or "no" as appropriate.

4. City, Town or Location of Death (Item 17A)

a. Enter the full name of the city, town, village or location where death occurred regardless of size.

b. If the death occurred on a moving conveyance and the body was first removed from the conveyance in this state, complete a death certificate and enter as the place of death the address where the body was first removed from the conveyance but also enter in parentheses the *actual* place of death insofar as it can be determined.

5. Parish of Death (17B). Enter the name of the parish in full. If the death occurred on a moving conveyance, enter the name of the parish where the decedent was first removed from the moving conveyance.

C. Section—Residence

1. Street Address (Item 18A). Enter the number and the street name of the place where the decedent lived. If the place has no number and street name, enter the rural route number or box number.

2. Parish of Residence (Item 18B). Enter the name of the parish/county in which the decedent lived.

3. State of Residence (Item 18C). Enter the name of the state of residence. This may be different than the state in the mailing address. If the decedent was not a resident of the United States, enter the name of the country and the name of the unit of government that is the nearest equivalent of a state.

4. Usual Residence of Decedent (Item 18D). Enter the full name of the city, town or location in which the decedent lived. This may differ from the city, town or location in the mailing address.

5. Zip Code (Item 18E). Enter the zip code of the place

where the decedent lived. This may differ from the zip code used in the mailing address.

6. Residence Inside City Limits (Item 18F). Enter "yes" or "no" as appropriate.

D. Section—Parents

1. Father's Last Name, First, Middle (Item 19A). The name of the father shall refer to the husband of the mother of the deceased, unless the biological father had formally acknowledged or legitimated the deceased prior to his/her death. Enter the last, first and middle name of the father. If the father had no middle name, enter "none." If not known, enter "unknown."

2. Father's Place of Birth (Item 19B). Enter the name of the city or location where the father was born. If unknown, enter "unknown."

3. Father's Place of Birth—State (Item 19C). Enter the name of the state where the father was born. If born outside of the United States, enter the name of the country. If not known, enter "unknown."

4. Mother's Maiden Name, First, Middle (Item 20A). The maiden surname of the mother is the name given at birth or adoption, not a name acquired by marriage. If the name is not known, enter "unknown." If there is no middle name, enter "none." If the middle name is unknown, enter "unknown."

5. Mother's Place of Birth (Item 20B). Enter the name of the city or location where the mother was born. If unknown, enter "unknown."

6. Mother's Place of Birth—State (Item 20C). Enter the name of the state where the mother was born. If born outside of the United States, enter the name of the country. If not known, enter "unknown."

E. Section—Informant

1. Informant's Name (Item 21A)

a. Type or print the name of the person who supplied the personal facts about the decedent and his or her family.

b. In the event that the information is taken from the institutional records, the entry shall indicate "name of institution" records and the name of the person extracting the information.

2. Informant's Address (Item 21B). Enter the complete mailing address of the informant whose name appears in item 21A. Be sure to include the zip code.

3. Date (Item 21C). Enter the date that the informant provided the information.

F. Section—Disposition. This section is to be completed by the funeral director or a person authorized to act in behalf of the funeral director.

1. Method of Disposition (Item 22A)

a. Check the appropriate block. If "other" is checked, specify method of disposition.

b. If the decedent was removed from the state and the cemetery or crematorium name and location are known, check burial or cremation and enter appropriate name and location in 22C. If decedent was removed from this state and the name and location of the crematorium or cemetery are unknown, check "removal."

2. Date Thereof (Item 22B). Enter the date in the specified format.

3. Name and Location of Cemetery or Crematorium (Item 22C). Enter the official name, address or location, including city or location and state of the cemetery or crematorium where final disposition is to be made.

4. Signature and Address of Funeral Director (Item 23A). The funeral director or person authorized to act in behalf of the funeral director, or other person managing the body shall sign in black, permanent ink and include the establishment name and the business address.

5. Facility Number (Item 23B). Enter the facility license number.

6. License Number (Item 23C). Enter the license number of the funeral director or funeral director/embalmer who signed the death certificate.

G. Section—Registrar

1. Alterations (Item 24). Enter annotations to document the reason for an alteration which occur after a death certificate is filed with either the local registrar or in the State Registry. The annotations should indicate the evidentiary basis for alteration, the date of the alteration and the signature of the official who altered the certificate.

2. Burial Transit Permit (Item 25A). The number of the Burial Transit Permit is entered here by the local registrar or special agent issuing it at the time of issuance. Note that permits are only issued upon presentation of a properly completed death certificate. However, if a funeral director presents a death certificate completed to the limits of his ability and resources and for reasons beyond his control he is unable to submit an entirely completed death certificate, a permit shall be issued. The permit is issued with the provision and understanding that the funeral director will present a completed document as soon as humanly possible. In the event that the funeral director abuses his privilege, the privilege will be withdrawn.

3. Parish of Issue (Item 25B). Enter the parish name in full where the permit was issued.

4. Date of Issue (25C). Enter the date that the Burial Transit Permit was issued.

5. Signature of Local Registrar (Item 26). Enter the signature of the local registrar of the parish where the certificate is filed. The signature shall be in permanent black ink.

H. Section—Manner of Death

1. Manner of Death (Item 27)

a. Complete this item for all deaths. Check the box corresponding to the manner of death. Deaths not due to external causes should be identified as "Natural." Usually, these are the only types of deaths a physician will certify. "Pending investigation" and "Could not be determined" refer to coroner cases only.

b. If the manner of death checked in item 27 is anything other than natural, items 28 a-f must be completed.

2. Date of Injury (Item 28A)

a. Enter the exact month, day, and year that the injury occurred. Enter the full name of the month, a standard abbreviation or a numeric value. If the exact date is not known, enter an estimated date (enter "est." before the date).

b. The date of injury may not necessarily be the same as the date of death.

3. Time of Injury (Item 28B)

a. Enter the time of injury (hours and minutes) according to local time. If daylight saving time is the official prevailing time where death occurs, it should be used to record the time of death. Be sure to indicate whether the time of death is a.m. or p.m.

b. Enter 12 noon as "12 noon." One minute after 12 noon is entered as "12:01 p.m."

c. Enter 12 midnight as "12 mid." A death that occurs at 12 midnight belongs to the night of the previous day, not the start of the new day. One minute after 12 midnight is entered as "12:01 a.m." of the new day.

d. If the exact time of death is unknown, the time should be estimated by the person who pronounces the body dead. "Est." should be placed before the time.

4. Injury at Work (Item 28C). Enter yes or no.

5. Describe How Injury Occurred (Item 28D). Enter a brief description of how the injury occurred. As examples: "shot in robbery," "fall from catwalk," "electrocuted installing wiring," "crushed by falling beam," etc.

6. Place of Injury (Item 28E). Specify where the injury occurred.

7. Location (Item 28F). Enter the complete address where the injury took place.

I. Section—Certifier. This section is to be completed only by the physician or coroner.

1. Certification of Attendant (Item 29A)

a. Enter dates of medical attendance of deceased if appropriate.

b. In accordance with R.S. 40:49B(5), if the death occurred more than 10 days after the decedent was last treated by a physician, the case shall be referred to the coroner for investigation to determine and certify the cause of death.

2. Signature of Physician or Coroner (Item 29B)

a. The person legally responsible shall sign in the space in permanent black ink indicating professional status, i.e., M.D. or coroner. The physician or coroner shall limit his signature to the space provided. *Note:* This section shall only be completed by the attending physician or coroner (including assistants) certifying death. No one else may sign for him and facsimiles or stamps shall not be acceptable.

b. If accident, suicide or homicide is checked, the signature shall be that of the coroner or his assistant in the parish where death due to external violence occurred.

3. Date (Item 29C). Enter the date that the certification statement was completed.

4. Type or Print Name of Physician or Coroner (Item 29D). The name of the physician or coroner certifying the death shall be typed (or printed) in permanent black ink.

5. Address of Physician or Coroner (Item 29E). Enter the street address, city and state of the attending physician or coroner.

J. Section—Cause of Death

1. Cause of Death (Item 30 Part I). Enter the diseases, injuries or complications that caused the death. Do not enter the mode of dying such as cardiac or respiratory arrest. Enter only one cause on each line followed by the approximate interval between onset and death.

2. Other Significant Conditions (Item 30 Part II). All

other important diseases or conditions that were present at the time of death and that may have contributed to the death but did not lead to the underlying cause of death listed in Part I should be recorded.

3. If Deceased was Female 10-49, was She Pregnant in the Last 90 Days? (Item 31). Check yes, no or unknown, or leave blank if not applicable.

4. Was an Autopsy Performed (Item 32A). Enter yes or no. Enter "yes" if a partial or complete autopsy was performed.

5. Were Autopsy Findings Available Prior to the Completion of Cause of Death (Item 32B). Enter yes or no. Enter "yes" if the autopsy findings were available prior to the completion of the cause of death. If an autopsy was conducted but the findings were not available and used to determine the cause of death, enter "no." If no autopsy was conducted, enter "no" or leave blank.

AUTHORITY NOTE: Promulgated in accordance with R.S. 40:32 et seq.

HISTORICAL NOTE: Promulgated by the Department of Health and Human Resources, Office of Preventive and Public Health Services, LR 13:246 (April, 1987), repromulgated by the Department of Health and Hospitals, Office of Public Health, LR 16:307, amended LR 19: (December 1993).

Rose Forrest
Secretary

RULE

Department of Health and Hospitals Office of the Secretary Bureau of Health Services Financing

Nurse Aide Registry

In accordance with the provision of the Administrative Procedure Act, R.S. 49:950 et seq., the Department of Health and Hospitals, Office of the Secretary, Bureau of Health Services Financing has repealed, in its entirety, the rule on Nurse Aide Decertification, published in the June 20, 1993 *Louisiana Register*, Volume 19, Number 6, page 752.

Rose V. Forrest
Secretary

RULE

Department of Health and Hospitals Office of the Secretary Bureau of Health Services Financing

Pharmacy Lock-In Program

In accordance with the provisions of the Administrative Procedure Act, R.S. 49:950 et seq., the Department of Health and Hospitals, Office of the Secretary, Bureau of Health Services Financing, has adopted the following rule in the Medical Assistance Program.

RULE

The Bureau of Health Services Financing may place any Medicaid beneficiary who has shown a consistent pattern of misuse of program benefits into the lock-in mechanism. Misuse may take the form of obtaining prescriptions under the pharmacy program from various physicians and/or pharmacists without these providers' knowledge that the beneficiary is receiving these drugs in an uncontrolled and unsound way.

Placement of Beneficiaries in the Lock-In Program

Potential lock-in beneficiaries will be identified through review of various reports generated by the Medicaid Management Information System or by referral from other interested parties to the Fiscal Intermediary for data analysis. Professional medical personnel affiliated with the Fiscal Intermediary and/or Department of Health and Hospitals examine data for a consistent pattern of misuse of program benefits by a beneficiary. Contact with involved providers may be initiated for additional information. The MMIS beneficiary profile may be shared with providers. Professional medical personnel associated with the Fiscal Intermediary and/or Department of Health and Hospitals may render a decision to place a beneficiary in the Pharmacy Lock-In Program. The decision is submitted, along with any provisions regarding providers, to a Department of Health and Hospitals designee for approval. The decision making authority rests solely with the Department of Health and Hospitals, Bureau of Health Services Financing.

Lock-In Procedures

The Bureau of Health Services Financing advises the Fiscal Intermediary of the decision to place a beneficiary in the Pharmacy Lock-In Program. The Fiscal Intermediary staff shall forward a notification to the local Medicaid office of the decision to place the beneficiary in the program and to initiate the necessary steps.

Beneficiary Notification

A. The local Medicaid office shall initiate the letter providing the beneficiary timely notice of the decision to lock-in providers and shall include the following additional information:

1. the bureau's intention to allow the beneficiary to choose one primary care provider and one pharmacy provider and a specialist provider;

2. that the Medical Assistance Program will make payments only to the physician and pharmacy providers chosen by the beneficiary and subsequently assigned by the bureau;

3. that a new eligibility card will be issued containing a special indicator identifying the beneficiary's lock-in status;

4. that the beneficiary is advised to contact his local Medicaid office for an appointment to discuss the Pharmacy Lock-In Program; and

5. that the beneficiary has the right to appeal the decision.

B. The local Medicaid office shall be responsible for the following:

1. initiate contact with the beneficiary in instances when the beneficiary fails to seek contact;

2. conduct a face-to-face interview with the beneficiary regarding the lock-in program and the beneficiary's rights and responsibilities;

3. assist the beneficiary, if necessary, in exercising due process rights; and complete Form 9-LI(2) at the initial contact and at each subsequent contact(s) when a beneficiary's choice of providers changes; and

4. notify the Fiscal Intermediary when beneficiaries refuse to choose providers.

C. The Fiscal Intermediary shall be responsible for the following:

1. ensure that production of regular eligibility card is suppressed upon receipt of Forms 9-LI(2) and 19LI;

2. verify to the local Medicaid office that the beneficiary has been locked in;

3. notify the local Medicaid office of confirmation or denial of providers;

4. notify the local Medicaid office of the effective month of lock-in;

5. ensure suppression of the regular eligibility card when the beneficiary refuses to choose providers and has not appealed the lock-in decision within 30 days of notification; and

6. initiate form to lock-in providers on the MMIS file;

7. notify lock-in providers of their selection.

The lock-in card with the special indicator may be issued either by the local eligibility office or the Fiscal Intermediary.

Restrictions

Beneficiaries shall be prohibited from choosing physicians and pharmacists who overprescribe or oversupply drugs. When the agency cannot approve a beneficiary's choice of provider(s), the lock-in beneficiary shall be required to make another selection.

Appeals

The beneficiary has the right to appeal the lock-in decision within 30 days of mailing the notice of action. If the receipt requests a hearing before the date of action, the decision to lock-in is stayed pending the appeal hearing. The beneficiary also has a right to an informal discussion. The Department of Health and Hospitals, Office of the Secretary, Bureau of Health Services Financing staff will conduct the informal telephone discussion in conjunction with local Medicaid office staff when requested. An explanation of the reason for recommending lock-in will be made to the beneficiary. If after the informal discussion the decision is reaffirmed to proceed with lock-in, the beneficiary will be given 30 days from the informal discussion notice of decision to file an

appeal. In instances when a beneficiary delays or postpones an appeal without prior notice, lock-in will be implemented.

General Provisions

A. Beneficiaries may change lock-in providers every year without cause. With good cause, they may change lock-in providers only with bureau's approval. Beneficiaries may change providers for the following "good cause" reasons: a beneficiary relocates, a beneficiary's primary diagnosis changes, requiring a different specialist, the lock-in provider(s) request(s) that the recipient be transferred, or the lock-in provider(s) stop(s) participating in the Medical Assistance Program. The beneficiary may still receive other program services available through Medicaid such as hospital, transportation, etc. which are not controlled or restricted by placing a beneficiary in lock-in for pharmacy and physicians services. No beneficiary on lock-in status shall be denied the service of a physician or pharmacist on an emergency basis within program regulations. The Medicaid eligibility card states that an enrolled provider will be reimbursed for such services. In instances in which a beneficiary is referred by his lock-in physician to another physician provider, reimbursement shall be made to the physician provider to whom the beneficiary was referred within program regulations.

B. Beneficiary profiles are to be reviewed periodically as described in the Lock-In Procedure Manual (for determination of continuance or discontinuance of LI). Professional Medical staff associated with the Fiscal Intermediary or Department of Health and Hospitals examine a recipient's profile for a continued pattern of misuse of program benefits. Periods of ineligibility for Medicaid will not affect the lock-in status of the individual. The local eligibility office will notify the Bureau of Health Services Financing upon reapplication and the recipient will be placed on a locked-in status. A review at the end of the first four months will be made to determine if lock-in should be continued. Based upon a recommendation of appropriate medical professional staff, a decision may be presented to Department of Health and Hospitals to restore unrestricted benefits and appropriate notification will be made to the beneficiary and the local eligibility office.

Rose V. Forrest
Secretary

RULE

Department of Health and Hospitals Office of the Secretary Medical Disclosure Panel

Informed Consent (LAC 48:I.Chapter 23)

As authorized by R.S. 40:1299.40E, as enacted by Act 1093 of 1990 and later amended by Act 962 of 1991 and Act 633 of 1993, the Department of Health and Hospitals, Medical Disclosure Panel, is adopting rules which require which risks must be disclosed under the Doctrine of Informed Consent to patients undergoing medical treatments or procedures and the Consent Form to be signed by the patient and physician before undergoing any such treatment or procedure. This amends rules adopted in *Louisiana Register* Vol. 18, No. 12, p. 1391-1399.

A copy of the full text of these revised rules may be obtained through the Office of the State Register, 1051 North Third Street, Baton Rouge, LA 70802.

Rose V. Forrest
Secretary

RULE

Department of Insurance Commissioner of Insurance

Regulation 45—Filing of Affirmative Action Plans

Under the authority of R.S. 22:3 and R.S. 49:950 et seq., the Commissioner of Insurance hereby adopts the following regulation, which establishes guidelines for filing affirmative action plans with the Commissioner of Insurance.

Proposed Regulation 45

Section 1. Authority

This regulation is promulgated under the authority of Title 22:1923 A.(1) of the Insurance Code of the State of Louisiana and the Administrative Procedure Act, R.S. 49:950 et seq.

Section 2. Purpose

The purpose of this regulation is to implement R.S. 22:1923 A.(1), which requires an insurer to file an affirmative action plan upon the violation of a cease and desist order issued by the commissioner after hearing.

Section 3. Applicability and Scope

This regulation applies to any insurer that is called for hearing before the commissioner for violating Part X of the Insurance Code (Equal Opportunity In Insurance) and found to be in violation of a Cease and Desist Order issued in accordance with the provisions of R.S. 22:1923 A. It sets forth the minimum content and procedures for the filing of an affirmative action plan by an insurer who violates Part X of the Insurance Code, and who then violates a cease and desist order issued by the commissioner after hearing.

Section 4. Content and Procedure

A. The commissioner shall notify an insurer of its violation of a cease and desist order issued pursuant to Part X of the Insurance Code by Certified U.S. Mail, return receipt requested. Said notification shall also direct the insurer to file an affirmative action plan.

B. The notice shall require the insurer to file its plan within 20 days of receipt of the notice.

C. The insurer shall file its plan by means of the U.S. Mail, and it shall contain the minimum requirements stated in R.S. 22:1923 C.(4)(a) and (b).

D. The insurer shall address the plan to the attention of the Office of Minority Affairs.

Section 5. Effective Date

This regulation shall become effective upon final promulgation in the *Louisiana Register*.

James H. "Jim" Brown
Commissioner of Insurance

RULE

Department of Labor Office of Labor

Job Training Partnership Act (LAC 40:XIII.Chapter 1)

Under the authority of R.S. 23:1 and R.S. 23:2022, and in accordance with R.S. 49:950 et seq., the Administrative Procedure Act, the Department of Labor, Office of Labor, has amended and adopted rules relative to the Job Training Partnership Act, LAC 40:XII.Chapter 1.

The Federal Job Training Partnership Act has been revised and amended by P.L. 102-367 effective July 1, 1993. The state JTPA rules, amended through a Declaration of Emergency, July 1, 1993 and published on pages 861-873 of the July 20, 1993 *Louisiana Register*, must be amended through the rulemaking process, including final rule promulgation as prescribed by R.S. 49:950 et seq.

TITLE 40

LABOR AND EMPLOYMENT

PART XIII. Job Training Partnership Act

Chapter 1. General Provisions

§101. Definitions

Capital Improvement—any modification, addition, restoration, or other improvement:

1. which increases the usefulness, productivity, or serviceable life of an existing building, structure, or major item of equipment;

2. which is classified for accounting purposes as a "fixed asset"; and

3. the cost of which increases the recorded value of the existing building, structure, or major item of equipment and is subject to depreciation.

Construction—the erection, installation, assembly, or painting of a new structure or a major addition, expansion, or

extension of an existing structure, and the related site preparation, excavation, filling and landscaping, or other land improvement.

Consulting Service—work, other than professional, personal, or social service, rendered by either individuals or firms who possess specialized knowledge, experience, or expertise to investigate assigned problems or projects and to provide counsel, review, design, development, analysis, or advice in formulating or implementing programs or services, or improvements in programs or services, including but not limited to such areas as management, personnel, finance, accounting, planning, data processing, and advertising contracts, except for printing associated therewith.

Dependent—any person for whom, both currently and during the previous 12 months, the applicant has assumed 50 percent of his support, and is:

1. a member of the immediate household (parent, spouse, or child); or

2. not a member of the household, but a parent, child or spouse of the applicant, who is unemployed because of a mental or physical disability; or

3. one who may be claimed as a dependent on the applicant's tax return.

Employing Agency—any public or private employer which employs participants and which establishes and maintains the personnel standards applicable to those participants covering such areas as wage rates, fringe benefits, job titles, and employment status.

Entry Level—the lowest position in any promotional line, as defined locally by collective bargaining agreements, past practice, or applicable personnel rules.

Family as defined by Section 4(34) of the Act means:

1. two or more persons living in a single residence, as defined in §626.5 of the regulations, related by blood, marriage, or decree of court and are included in one or more of the following categories. A stepchild or a stepparent is considered to be related by marriage.

- a. husband, wife and dependent child;
- b. parent or guardian and dependent child;
- c. husband and wife;

2.a. for purposes of Paragraph 1 above, persons not living in the single residence but who were claimed as a dependent on another person's Federal Income Tax return for the previous year, unless otherwise demonstrated, shall be presumed to be part of the other person's family;

b. a handicapped individual may be considered an individual when applying for programs under the Act;

c. an individual 18 years of age or older, except as provided in 2.a. or 2.b. above, who receives less than 50 percent of support from the family, and who is not the principal earner nor the spouse of the principal earner, is not considered a member of the family. Such an individual is considered a family of one.

Family Income—all income received from all sources by all members of the family for the six-month period prior to application computed on an annual basis. Family size shall be the maximum number of family members during the income determination period. When computing family income, income of a spouse, parent or child shall be counted for the

portion of the income determination period that the person was actually a part of the family unit of the applicant.

1. In accordance with §626.5 of the JTPA Regulations, for the purpose of determining eligibility, family income includes:

a. money wages and salaries before any deductions;

b. net receipts from nonfarm self-employment (receipts from a person's own unincorporated business, professional enterprise, or partnership, after deductions for business expenses);

c. net receipts from farm self-employment (receipts from a farm which one operates as an owner, renter, or sharecropper, after deductions for farm operating expenses);

d. regular payments from social security, railroad retirement, strike benefits from union funds, workers' compensation, veterans' payments, and training stipends;

e. alimony;

f. military family allotments or other regular support from an absent family member or someone not living in the household;

g. pensions whether private, government employee (including military retirement pay);

h. regular insurance or annuity payments;

i. college or university grants, fellowships, and assistantships;

j. dividends, interest, net rental income, net royalties, periodic receipts from estates or trusts;

k. net gambling or lottery winnings.

2. Family income does not include:

a. unemployment compensation;

b. child support payments;

c. welfare payments (including Aid to Families with Dependent Children, Supplemental Security Income, Emergency Assistance money payments, and non-federally-funded General Assistance or General Relief money payments);

d. capital gains;

e. any assets drawn down as withdrawals from a bank, the sale of property, a house, or a car;

f. tax refunds, gifts, loans, lump-sum inheritances, one-time insurance payments, or compensation for injury;

g. non-cash benefits:

i. employer-paid fringe benefits;

ii. food or housing received in lieu of wages;

iii. Medicare or Medicaid;

iv. food stamps;

v. school meals;

vi. housing assistance.

Job Training Plan—the plan of a service delivery area for operating programs under the Act, consisting of the Master Plan and Program Plan.

Labor Organization—a local labor organization that represents employees in the service delivery area in the same or substantially equivalent jobs as those for which recipients and subrecipients provide, or propose to provide, employment and training under the Act.

Limited English Language Proficiency—the limited ability of a participant, whose native language is not English, to communicate in English, resulting in a job handicap.

Long-Term Unemployment—any individual who is unemployed at the time of application and has been unemployed for 15 or more of the 26 weeks immediately prior to such and has limited opportunities for employment and reemployment in the same or similar occupation in the area in which such individual resides, including any older individual who may have substantial barriers to employment by reason of age.

Master Plan—the part of the Job Training Plan which serves as a long-term agreement between the governor and a service delivery area.

Matching Funds for Eight Percent Programs—shall include all non-JTPA funds, whether in cash or in kind, used in direct support of employment or training services provided by state or local educational agencies.

Part-Time Employment—employment in which a worker is regularly scheduled to work less than the employer's full-time schedule for the worker's position.

Personal Service—work rendered by individuals which require use of creative or artistic skills, such as but not limited to graphic artists, sculptors, musicians, photographers, and writers, or which require use of highly technical or unique individual skills or talents, such as, but not limited to, paramedics, therapists, handwriting analysts, and expert witnesses for adjudications or other court proceedings.

Placement—the act of securing unsubsidized employment for or by a participant.

Professional Service—work rendered by an independent contractor who has a professed knowledge of some department of learning or science used by its practical application to the affairs of others or in the practice of an art founded on it, which independent contractor shall include but not be limited to lawyers, doctors, dentists, veterinarians, architects, engineers, landscape architects, and accountants. A profession is a vocation founded upon prolonged and specialized intellectual training which enables a particular service to be rendered. The word "professional" implies professed attainments in special knowledge as distinguished from mere skill.

Program Plan—the part of the Job Training Plan which consists of the description of program activities and services to be provided by the service delivery area during the program year.

Property—all tangible non-consumable moveable property purchased with funds under the Act. The term moveable distinguishes this type of property from property attached as a permanent part of a building or structure. Please note that state law requires each item of moveable property having an acquisition cost or appraised value of \$250 or more to be placed on inventory.

Public Service Employment—the type of work normally provided by governments and includes, but is not limited to work (including part-time work) in such fields as environmental quality, child care, health care, education, crime prevention and control, prisoner rehabilitation, transportation, recreation, maintenance of parks, streets, and other public facilities, solid waste removal, pollution control, housing and neighborhood improvement, rural development, conservation, beautification, veterans outreach, development

of alternative energy technologies, and other fields of human betterment and community improvement. This activity is distinguished from work experience in that in general PSE is full-time and long term or open-ended and the participant is employed by the agency involved and not the SDA.

Real Property—land, including land improvements, structures and appurtenances thereto, excluding movable machinery and equipment.

Unsubsidized Employment—employment not financed from funds provided under the Act. In accordance with Section 106(k) of the Act for performance standard purposes, employment means employment for 20 or more hours per week.

Welfare Recipient—an individual who receives or whose family receives cash payments under AFDC (Title IV of the Social Security Act), General Assistance, or the Refugee Assistance Act of 1980 (P.L. 96-212). (This term excludes recipients of supplemental security income under Title XVI of the Social Security Act.)

AUTHORITY NOTE: Promulgated in accordance with R.S. 23:2022.

HISTORICAL NOTE: Promulgated by the Department of Labor, Office of Labor, LR 9:331 (May 1983), amended LR 9:473 (July 1983), LR 10:546 (July 1984), LR 12:439 (July 1986), LR 13:359 (June 1987), repealed and repromulgated by the Department of Employment and Training, Office of Labor, LR 17:357 (April 1991), amended by the Department of Labor, Office of Labor, LR 19: (December 1993).

§103. Pre-award Financial Review

Repealed.

AUTHORITY NOTE: Promulgated in accordance with R.S. 23:2022.

HISTORICAL NOTE: Promulgated by the Department of Labor, Office of Labor, LR 9:333 (May 1983), repealed and repromulgated by the Department of Employment and Training, Office of Labor, LR 17:357 (April 1991), repealed by the Department of Labor, Office of Labor, LR 19: (December 1993).

§105. Accounting Procedures

Accounting for JTPA funds must be on an accrual basis in accordance with generally acceptable accounting principles. In accordance with §627.430(g)(2) of the regulations, a recipient/subrecipient shall not be required to maintain a separate bank account but shall separately account for federal funds on deposit.

AUTHORITY NOTE: Promulgated in accordance with R.S. 23:2022.

HISTORICAL NOTE: Promulgated by the Department of Labor, Office of Labor, LR 9:333 (May 1983), repealed and repromulgated by the Department of Employment and Training, Office of Labor, LR 17:357 (April 1991), amended by the Department of Labor, Office of Labor, LR 19: (December 1993).

§107. Reporting of Expenditures

The service delivery area grant recipient shall prepare expenditure reports in accordance with procedures established by the recipient. These reports shall be on an accrual basis and conform to federal and state requirements in regard to the Act.

AUTHORITY NOTE: Promulgated in accordance with R.S. 23:2022.

HISTORICAL NOTE: Promulgated by the Department of Labor, Office of Labor, LR 9:333 (May 1983), repealed and repromulgated

by the Department of Employment and Training, Office of Labor, LR 17:357 (April 1991), amended by the Department of Labor, Office of Labor, LR 19: (December 1993).

§109. Requests for Cash

The financing of the JTPA program will be on an advance or reimbursement basis in accordance with procedures established by the recipient. Service delivery area grant recipients shall establish procedures that will minimize the time elapsing between the receipt of advanced funds and their disbursements in accordance with 31 CFR part 205. At no time shall the service delivery area grant recipient have funds which exceed three days expenditure needs.

AUTHORITY NOTE: Promulgated in accordance with R.S. 23:2022.

HISTORICAL NOTE: Promulgated by the Department of Labor, Office of Labor, LR 9:333 (May 1983), repealed and repromulgated by the Department of Employment and Training, Office of Labor, LR 17:357 (April 1991), amended by the Department of Labor, Office of Labor, LR 19: (December 1993).

§111. Purchasing Procedures

All purchases and leases of furniture, equipment, supplies, property, office and building space, capital improvements, and services shall be processed in accordance with procedures established by the recipient. All purchases of furniture, equipment, supplies, property, office and building space, and capital improvements, with a unit cost of \$5,000 or more must have the prior approval of the recipient.

AUTHORITY NOTE: Promulgated in accordance with R.S. 23:2022.

HISTORICAL NOTE: Promulgated by the Department of Labor, Office of Labor, LR 9:333 (May 1983), repealed and repromulgated by the Department of Employment and Training, Office of Labor, LR 17:357 (April 1991), amended by the Department of Labor, Office of Labor, LR 19: (December 1993).

§112. Advertising

Advertising media includes newspapers, magazines, radio and television programs, direct mail, trade papers, and the like. The advertising costs allowable are those which are solely for:

1. recruitment of personnel required for the grant program;
2. solicitation of bids for the procurement of goods and services required;
3. disposal of scrap or surplus materials acquired in the performance of the grant agreement;
4. recruitment of participants, employers, other service providers, and general advertising for the SDA; and
5. other purposes specifically provided for in the grant agreement.

AUTHORITY NOTE: Promulgated in accordance with R.S. 23:2022.

HISTORICAL NOTE: Promulgated by the Department of Labor, Office of Labor, LR 19: (December 1993).

§113. Travel and Transportation Regulations

A. All reimbursement for travel will be made in accordance with the travel regulations of the recipient, service delivery area grant recipient, administrative entity or subrecipient. Where subrecipient travel regulations are utilized, they shall at a minimum, conform with applicable standards of the recipient, service delivery area grant recipient, or administrative entity.

B. Travel costs are allowable for expenses for transportation, lodging, subsistence, and related items incurred by employees who are in travel status on official business incident to the recipient or subrecipient program. Such costs may be charged on an actual basis on a per diem or mileage basis in lieu of actual costs incurred, or on a combination of the two provided the method used is applied to an entire trip and results in charges consistent with those normally allowed in like circumstances in nonfederally sponsored activities. The difference in cost between first-class air accommodations and less-than-first-class air accommodations are unallowable except when less-than-first-class air accommodations are not reasonably available. Each recipient or subrecipient must have clearly defined travel regulations including documentation requirements. These requirements must include travel reports which include the date of travel, travel destination, purpose, beginning and ending odometer reading, amount to be reimbursed, and supervisor signatures.

C. Costs incurred for freight, cartage, express, postage and other transportation costs relating either to goods purchased, delivered, or moved from one location to another are allowable.

AUTHORITY NOTE: Promulgated in accordance with R.S. 23:2022.

HISTORICAL NOTE: Promulgated by the Department of Labor, Office of Labor, LR 9:333 (May 1983), repealed and repromulgated by the Department of Employment and Training, Office of Labor, LR 17:357 (April 1991), amended by the Department of Labor, Office of Labor, LR 19: (December 1993).

§114. Printing and Reproduction Costs

Costs for printing and reproduction services necessary for grant administration, including but not limited to forms, reports, manuals, and informational literature are allowable. Reasonable publication costs of reports or other media relating to grant program accomplishments or results are allowable.

AUTHORITY NOTE: Promulgated in accordance with R.S. 23:2022.

HISTORICAL NOTE: Promulgated by the Department of Labor, Office of Labor, LR 19: (December 1993).

§115. Personnel, Salary Regulations and Fringe Benefits

A. All employment practices, salary schedules and related personnel procedures will be in accordance with the regulations of the service delivery area grant recipient, administrative entity or subrecipient.

B. Compensation for personal services includes all remuneration, paid currently or accrued, for services rendered during the period of performance under the grant agreement, including but not necessarily limited to wages, salaries, and supplementary compensation and benefits. The costs of such compensation are allowable to the extent that total compensation for individual employees:

1. is reasonable for the services rendered;
2. follows an appointment made in accordance with recipient or subrecipient rules; and
3. is determined to be supported as provided below. Compensation surveys providing data representative of the labor market involved will be an acceptable basis for evaluating reasonableness.

C. Amounts charged to grant programs for personnel services will be based on payrolls documented and provided in

accordance with generally accepted practice of the recipient or subrecipient. Payrolls must be supported by time and attendance or equivalent records for individuals. Salaries and wages of employees chargeable to more than one grant program or other cost objective will be supported by appropriate time distribution records. The method used should produce an equitable distribution of time and effort.

D. Employee benefits in the form of regular compensation paid to employees during periods of authorized absences from the job, such as for annual leave, sick leave, court leave, military leave and the like are allowable, if they are:

1. provided pursuant to an approved leave system; and
2. the cost thereof is equitably allocated to all related activities, including grant programs.

E. Employee benefits in the form of employers' contribution or expenses for social security, employee's life and health insurance coverage, workers' compensation insurance, pension plans, severance pay, and the like, are allowable, provided such benefits are granted under approved plans and are distributed equitably to grant programs and to other activities.

AUTHORITY NOTE: Promulgated in accordance with R.S. 23:2022.

HISTORICAL NOTE: Promulgated by the Department of Labor, Office of Labor, LR 9:334 (May 1983), repealed and repromulgated by the Department of Employment and Training, Office of Labor, LR 17:357 (April 1991), amended by the Department of Labor, Office of Labor, LR 19: (December 1993).

§116. Advisory Councils

Costs incurred by state advisory councils or committees, including the GETCC and PICs, established pursuant to the JTPA Regulations to carry out grant programs are allowable.

AUTHORITY NOTE: Promulgated in accordance with R.S. 23:2022.

HISTORICAL NOTE: Promulgated by the Department of Labor, Office of Labor, LR 19: (December 1993).

§117. Auditing Requirements

SDA grant recipients, administrative entities and subrecipients who are government or non-profit entities must comply with the audit requirements of the "Single Audit Act of 1984"/OMB Circular-128 or OMB-Circular 133 as appropriate. Commercial organizations who are subrecipients shall be audited in accordance with §627.480(a)(3) of the federal regulations. Audit costs for auditing SDA grant recipients and administrative entities will be paid from state administrative funds upon request. Audit costs for subrecipients of SDA grant recipients and administrative entities must be paid by the service delivery area grant recipient or administrative entity. Other subrecipients contracted directly by the Louisiana Department of Labor will be audited in accordance with the "Single Audit Act of 1984" which incorporates the use of private audit firms or the legislative auditors.

AUTHORITY NOTE: Promulgated in accordance with R.S. 23:2022.

HISTORICAL NOTE: Promulgated by the Department of Labor, Office of Labor, LR 9:334 (May 1983), repealed and repromulgated by the Department of Employment and Training, Office of Labor, LR 17:357 (April 1991), amended by the Department of Labor, Office of Labor, LR 19: (December 1993).

§119. Non-allowable Costs

In accordance with §627.435(e) (f) and (i) of the federal regulations some costs associated with JTPA are not considered as necessary and reasonable for proper and efficient administration of the program. These include:

1. costs of fines and penalties resulting from violations of or failure to comply with federal, state, or local laws and regulations;
2. back pay, unless it represents additional pay for JTPA services performed for which the individual was underpaid;
3. entertainment costs;
4. bad debts expenses;
5. insurance policies offering protection against debts established by the federal government;
6. contributions to a contingency reserve or any similar provision for unforeseen events;
7. costs prohibited by 29 CFR part 93 (Lobbying Restrictions);
8. costs of activities prohibited in §627.205, Public Service Employment Prohibition, §627.210; Nondiscrimination and Nonsectarian Activities; and §627.215, Relocation; §627.225, Employment Generating Activities; and §627.230, Displacement of the Federal Regulations;
9. legal services furnished by the chief legal officer of a state or local government or staff solely for the purpose of discharging general responsibilities as a legal officer are unallowable;
10. legal expenses for the prosecution of claims against the federal government, including appeals to an administrative law judge, are unallowable;
11. construction costs are not allowable costs except those specified in §627.435(h)(1) and (2) of the federal regulations;
12. fund-raising activities;
13. interest expense including interest on borrowing, bond discounts, cost of financing and refinancing operations, and legal and professional fees paid in connection therewith;
14. contributions and donations as specified in OMB Circular A-87.

AUTHORITY NOTE: Promulgated in accordance with R.S. 23:2022.

HISTORICAL NOTE: Promulgated by the Department of Labor, Office of Labor, LR 9:334 (May 1983), repealed and repromulgated by the Department of Employment and Training, Office of Labor, LR 17:357 (April 1991), amended by the Department of Labor, Office of Labor, LR 19: (December 1993).

§120. Fees or Profits

Any fees or profits earned by the SDA grant recipient or subrecipients must be consistent with §627.420(e)(3) of the federal regulations.

AUTHORITY NOTE: Promulgated in accordance with R.S. 23:2022.

HISTORICAL NOTE: Promulgated by the Department of Labor, Office of Labor, LR 19: (December 1993).

§121. Carry-Over Balances

Funds obligated for any program year may be expended by each recipient or service delivery area grant recipient during that program year and the two succeeding program years with the following exceptions:

1. Title II-A and Title II-C Reallotment and Reallocation Policy

a. For program years beginning on or after July 1, 1993, the governor shall, in accordance with §109 of the Act and §627.410 of the federal regulations, reallocate to eligible service delivery areas within the state funds appropriated for such program year that are available for reallocation.

b. The amount available for reallocation is equal to the amount by which the unobligated balance of the SDA's allocation under Part A and Part C of Title II at the end of the program year prior to the program year for which the determination is made exceeds 15 percent of such allocation for the prior program year.

c. In addition, Louisiana will use the reallotment process for SDAs at the end of each program year whether or not the state is subject to a reduction in funding due to reallotment. This will allow the state to deal with significant underexpenditure of funds by individual SDAs even when the state maintains a high overall level of expenditures.

d. In the event that Louisiana is not subject to a reduction in funding, but one or more SDAs are subject to a reduction based on Louisiana's policy, funds deobligated from such SDAs will be allocated to the remaining SDAs who are not subject to a reduction that have the highest rates of unemployment for an extended period of time and to those with the highest poverty rates.

2. Title II-B - Reallocation Policy

a. Section 161(b) of the Act provides that no amount of funds "shall be deobligated on account of a rate of expenditure which is consistent with the job training plan." In order to remain consistent with this policy, if an SDA's rate of expenditure is inconsistent with the job training plan, its new obligational authority (NOA) may be reduced in subsequent years in order to, in effect, reallocate funds from that program year.

b. Beginning in Program Year 1995 and applying to Program Year 1994, an amount equivalent to 15 percent of the previous year's total funds available will be classified as "allowable carry-out."

c. All other carry-out will be designed as "excess carry-out" and the obligational authority (NOA) to the SDA will be reduced by the amount of the excess carry-out. Determination of total carry-out and the excess carry-out will be made after submittal of the final program year expenditure report and reallocation of funds will be made to those SDAs which request the funds and have expended more than 85 percent of their total funds available. The reallocation will be based on the degree that SDAs exceed the 85 percent expenditure level.

3. Title III - Reallotment and Reallocation Policy

a. Excess Unexpended Funds

i. The U.S. Department of Labor has established Title III reallotment procedures that have the effect of limiting the amount of unexpended funds that can be carried-over by the state at the end of each program year. Reallotment also rewards states with high expenditure rates by providing additional funds. These procedures are described in Section 303 of the Job Training Partnership Act, Section 6305(e) of the Economic Dislocation and Worker Adjustment Assistance

Act, §631.12 of JTPA Federal Regulation, and Training and Employment Guidance Letter (TEGL) No. 4-88 issued by the U.S. Department of Labor.

ii. Reallotment will occur around September 1 and will result in an increase or decrease in the state's formula-allotted funds for the current year based on a reallotment process applied to the prior year's Title III funds and expenditures. When reallotment results in an increase in funding, such reallocation is subject to allocation procedures specified in §631.32 of the federal regulations. When reallotment results in a decrease in funding, the procedures that follow will be used to recover funds from substate grantees and, where appropriate, state subcontractors in order to make funds available to the U.S. Department of Labor for reallotment. Any remaining funds would come from the governor's 40 percent funds.

iii. Louisiana will apply the same reallotment procedures to sub-state grantees and state subcontractors that the U.S. Department of Labor applies to the state. Our reallotment policy states that the amount available for reallotment from substate grantees and state subcontractors is equal to the sum of unexpended funds in excess of 20 percent of the prior year's allocation or subgrant amount and all unexpended previous program year funds. For PY 88 allocations and subgrants, 30 percent shall be substituted for 20 percent in the previous sentence. Unexpended reallocated funds at the end of the year will also be subject to the 20 percent limitation on allowable carry forward. Substate grantees and state subcontractors that lose funds through the reallotment process will use their allocation or subgrant amount before reallotment in order to calculate allowable carry forward.

iv. In addition, Louisiana will use the reallotment process for substate grantees and, where appropriate, state subcontractors at the end of each program year whether or not the state is subject to a reduction in funding due to reallotment. This will allow the state to deal with significant underexpenditure of funds by individual substate grantees and state subcontractors even when the state maintains a high overall level of expenditures.

v. In the event that Louisiana is not subject to a reduction in funding, but one or more substate grantee(s) or state subcontractor(s) are subject to a reduction based on Louisiana's policy, funds deobligated from such substate grantees will be allocated by formula to the remaining substate grantees who were not subject to a reduction. This allocation will be in addition to any funds reallocated by the U.S. Department of Labor and subsequently allocated to substate areas. Any funds deobligated from state subcontractors as a result of these procedures are subject to regular Title III state obligation procedures.

b. Projected Excess Unexpended Funds

i. Louisiana is subject to a U.S. Department of Labor JTPA Title III reallotment process based on expenditures at the end of each program year. In order to avoid a reduction in funding from such a reallotment, a deobligation procedure has been established.

ii. Title III substate grantees and state subcontractors are subject to deobligation of projected excess unexpended

funds based on expenditures during the first five months of their subgrant or subcontract period. Projected excess unexpended funds are defined as any amount of projected unexpended funds in excess of 20 percent of a substate grantee's available funds (excluding carry-in funds and any additional funds reallocated during that program year as a result of the U.S. Department of Labor's reallocation process) or 20 percent of a subcontract amount. Projected unexpended funds are total available funds (excluding reallocated funds) less expenditures reported for the first five months and less an amount equal to the higher of the last two months reported expenditure amounts times the number of months remaining in the subgrant or subcontract period. Expenditure amounts used for this process will be those amounts reported as of the official due date specified by the Louisiana Department of Labor's fiscal section. Funds remaining after deobligation will be subject to all cost category limitations.

iii. Substate grantees and state subcontractors will have 15 days from the date they are notified of any amount subject to deobligation to provide documentation to the Louisiana Department of Labor why they should not be subject to such deobligation. The Louisiana Department of Labor may reduce the amount to be deobligated based on acceptance of documentation of corrected expenditure amounts, significant recent obligations not reflected in current reported expenditures, or other appropriate justification.

iv. All funds deobligated from substate grantees will be allocated by formula to substate grantees whose total projected unexpended funds are not expected to exceed allowable projected unexpended funds. Funds deobligated from state subcontractors are subject to regular Title III state obligation procedures.

v. This deobligation procedure does not limit the Louisiana Department of Labor's authority to unilaterally deobligate funds from subgrants and subcontractors when it is deemed necessary in order to carry out responsibilities under the Job Training Partnership Act.

4. Reallocation Waiver. The reallocation policies may be waived for SDAs and substate grantees operating under a reorganization plan issued by the governor in accordance with procedures established by the recipient.

AUTHORITY NOTE: Promulgated in accordance with R.S. 23:2022.

HISTORICAL NOTE: Promulgated by the Department of Labor, Office of Labor, LR 9:334 (May 1983), amended LR 10:546 (July 1984), LR 15:496 (June 1989), repealed and repromulgated by the Department of Employment and Training, Office of Labor, LR 17:357 (April 1991), amended LR 18:372 (April 1992), repromulgated LR 18:493 (May 1992), amended by the Department of Labor, Office of Labor, LR 19: (December 1993).

§122. Depreciation and/or Use Allowance

A. Compensation for the use of buildings, capital improvements, and equipment through use allowances or depreciation is allowable. Use allowances are the means of providing compensation in lieu of depreciation or other equivalent costs. However, a combination of the two methods may not be used in connection with a single class of fixed assets.

B. The computation of depreciation or use allowance will

be in accordance with A-87 Cost Principles for State and Local Governments, Attachment B.

C. Depreciation or use allowance on idle or excess facilities is not allowable, except when specifically authorized by the grantor federal agency.

D. No depreciation or use charge may be allowed on any assets that would be considered as fully depreciated, provided, however, that reasonable use charges may be negotiated for any such assets if warranted after taking into consideration the cost of the facility or item involved, the estimated useful life remaining at time of negotiation, the effect of any increased maintenance charges or decreased efficiency due to age, and any other factors pertinent to the utilization of the facility or item for the purpose contemplated.

AUTHORITY NOTE: Promulgated in accordance with R.S. 23:2022.

HISTORICAL NOTE: Promulgated by the Department of Labor, Office of Labor, LR 19: (December 1993).

§123. Program Income Guidelines

Repealed.

AUTHORITY NOTE: Promulgated in accordance with R.S. 30:2022.

HISTORICAL NOTE: Promulgated by the Department of Labor, Office of Labor, LR 9:334 (May 1983), repealed and repromulgated by the Department of Employment and Training, Office of Labor, LR 17:357 (April 1991), repealed by the Department of Labor, Office of Labor, LR 19: (December 1993).

§124. Building Space and Related Facilities

A. The cost of space in privately or publicly owned buildings used for the benefit of the grant program is allowable subject to the conditions stated below.

B. The total cost of space, whether in a privately or publicly owned building may not exceed the rental cost of comparable space and facilities in a privately owned building in the same locality. The cost of space procured for grant program usage may not be charged to the program for periods of nonoccupancy without authorization of the recipient agency.

C. The cost of utilities, insurance, security, janitorial services, elevator services, upkeep of grounds, normal repairs and alternations and the like, are allowable to the extent they are not otherwise included in the rental or other charges for space.

D. Costs incurred for rearrangement and alteration of facilities required specifically for the grant program or those that materially increase the value or useful life of the facilities are allowable when specifically approved by the recipient.

E. Costs incurred for necessary maintenance, repair, or upkeep of property which neither add to the permanent value of the property nor appreciably prolong its intended life, but keep it in an efficient operating condition are allowable.

F. Depreciation and use allowances on publicly owned buildings are allowable as provided in §122 of these state rules (Depreciation and Use Allowance).

AUTHORITY NOTE: Promulgated in accordance with R.S. 23:2022.

HISTORICAL NOTE: Promulgated by the Department of Labor, Office of Labor, LR 19: (December 1993).

§125. Financial and Programmatic Monitoring and Record Retention

The recipient reserves the right to monitor the financial and

programmatic operations of all service delivery area grant recipients. The service delivery area grant recipients shall comply with the record retention requirements at 20 CFR 627.460.

AUTHORITY NOTE: Promulgated in accordance with R.S. 23:2022.

HISTORICAL NOTE: Promulgated by the Department of Labor, Office of Labor, LR 9:334 (May 1983), repealed and repromulgated by the Department of Employment and Training, Office of Labor, LR 17:357 (April 1991), amended by the Department of Labor, Office of Labor, LR 19: (December 1993).

§126. Insurance Costs

Costs of insurance in connection with the general conduct of activities under the program, including but not limited to, workers' compensation insurance, insurance for injuries suffered by participants who are not covered by workers' compensation, personal liability insurance for PIC members, and insurance covering the risk of loss of, or damage to JTPA property, are allowable subject to the following limitations:

1. Types and extent and cost of coverage will be in accordance with general state and local policy and sound business practice;

2. Contributions to a reserve for a self-insurance program approved by the recipient are allowable to the extent that the type of coverage, extent of coverage, and the rates and premiums would have been allowed had the insurance been purchased to cover the risks.

3. Actual losses which could have been covered by permissible insurance (through an approved self-insurance program or otherwise) are unallowable unless expressly provided for in the grant agreement. However, costs incurred because of losses not covered under nominal deductible insurance coverage provided in keeping with sound management practice, and minor losses not covered by insurance, such as spoilage, breakage and disappearance of small hand tools which occur in the ordinary course of operations, are allowable.

AUTHORITY NOTE: Promulgated in accordance with R.S. 23:2022.

HISTORICAL NOTE: Promulgated by the Department of Labor, Office of Labor, LR 19: (December 1993).

§127. Inventory Control

Property purchased or assumed under the act must be maintained in an efficient and effective manner and shall not be used for purposes other than the act. Service delivery area grant recipients shall obtain written approval from the recipient prior to the disposition of property covered by the act. Proceeds of such disposition shall be considered program income as regulated by Section 141(m) of the act and §627.450 of the regulations. Please note that state law requires each item of moveable property having an acquisition cost or appraised value of \$250 or more to be placed on inventory.

AUTHORITY NOTE: Promulgated in accordance with R.S. 23:2022.

HISTORICAL NOTE: Promulgated by the Department of Labor, Office of Labor, LR 9:334 (May 1983), repealed and repromulgated by the Department of Employment and Training, Office of Labor, LR 17:357 (April 1991), amended by the Department of Labor, Office of Labor, LR 19: (December 1993).

§128. Taxes

In general, taxes or payments in lieu of taxes which the recipient/subrecipient is legally required to pay are allowable.

AUTHORITY NOTE: Promulgated in accordance with R.S. 23:2022.

HISTORICAL NOTE: Promulgated by the Department of Labor, Office of Labor, LR 19: (December 1993).

§129. Contractual Agreement

A. The service delivery area grant recipients may enter into contractual agreements with any profit and/or nonprofit organization. Service delivery area grant recipients will be responsible for their subrecipients' financial and programmatic operations and will insure compliance with state and federal regulations. Service delivery area grant recipients may require their subrecipients to implement policies in those areas mentioned in these rules similar to the service delivery area grant recipient's policies. The recipient has the right to inspect financial records or program records of any service delivery area grant recipient or subrecipients.

B. In accordance with §627.422 of the federal regulations, each SDA shall ensure that, for all services provided to participants through contracts, grants, or other agreements with a service provider, such contract, grant, or agreement shall include appropriate amounts necessary for administration and supportive services.

AUTHORITY NOTE: Promulgated in accordance with R.S. 23:2022.

HISTORICAL NOTE: Promulgated by the Department of Labor, Office of Labor, LR 9:334 (May 1983), repealed and repromulgated by the Department of Employment and Training, Office of Labor, LR 17:357 (April 1991), amended by the Department of Labor, Office of Labor, LR 19: (December 1993).

§130. Preagreement Costs

Costs incurred prior to the effective date of the grant or contract, whether or not they would have been allowable thereunder if incurred after such date, are allowable when specifically provided for in the grant agreement.

AUTHORITY NOTE: Promulgated in accordance with R.S. 23:2022.

HISTORICAL NOTE: Promulgated by the Department of Labor, Office of Labor, LR 19: (December 1993).

§131. Bonding

Every officer, director, agent or employee of a service delivery area grant subrecipient of JTPA funds on a cash advance basis, who is authorized to act on behalf of a service delivery area grant recipient for the purpose of receiving or depositing funds into program accounts or issuing financial documents, checks or other instruments of payment for program costs shall be bonded to provide protection against loss. The amount of coverage shall be the lower of the following:

1. \$50,000; or
2. the highest advance through check or drawdown planned during the contract/subgrant period.

AUTHORITY NOTE: Promulgated in accordance with R.S. 23:2022.

HISTORICAL NOTE: Promulgated by the Department of Labor, Office of Labor, LR 9:334 (May 1983), repealed and repromulgated by the Department of Employment and Training, Office of Labor, LR 17:357 (April 1991), amended by the Department of Labor, Office of Labor, LR 19: (December 1993).

§133. Professional, Personal, and Consultant Services

A. Contracts for professional, personal, and consultant services are allowable with prior written approval of the recipient and in accordance with procedures established by the recipient. Approval must be obtained annually.

B. The costs of management studies to improve the effectiveness and efficiency of grant management for ongoing programs is allowable except that the costs of studies performed by agencies or individuals other than the recipient are allowable only with prior written approval of the recipient.

AUTHORITY NOTE: Promulgated in accordance with R.S. 23:2022.

HISTORICAL NOTE: Promulgated by the Department of Labor, Office of Labor, LR 9:334 (May 1983), repealed and repromulgated by the Department of Employment and Training, Office of Labor, LR 17:357 (April 1991), amended LR 18:372 (April 1992), amended by the Department of Labor, Office of Labor, LR 19: (December 1993).

§135. Funds for Cooperative Agreements

Repealed.

AUTHORITY NOTE: Promulgated in accordance R.S. 23:2022.

HISTORICAL NOTE: Promulgated by the Department of Labor, Office of Labor, LR 9:334 (May 1983), repealed and repromulgated by the Department of Employment and Training, Office of Labor, LR 17:357 (April 1991), repealed by the Department of Labor, Office of Labor, LR 19: (December 1993).

§137. Contents of Cooperative Agreement

Repealed.

AUTHORITY NOTE: Promulgated in accordance with R.S. 23:2022.

HISTORICAL NOTE: Promulgated by the Department of Labor, Office of Labor, LR 9:334 (May 1983), repealed and repromulgated by the Department of Employment and Training, Office of Labor, LR 17:357 (April 1991), repealed by the Department of Labor, Office of Labor, LR 19: (December 1993).

§139. Deobligation of State Education Cooperative Agreement Funds

Repealed.

AUTHORITY NOTE: Promulgated in accordance with R.S. 23:2022.

HISTORICAL NOTE: Promulgated by the Department of Labor, Office of Labor, LR 9:334 (May 1983), repealed and repromulgated by the Department of Employment and Training, Office of Labor, LR 17:357 (April 1991), repealed by the Department of Labor, Office of Labor, LR 19: (December 1993).

§141. Redesignation of Service Delivery Area Grant Recipient

Petitions for redesignation of a service delivery area must be filed with the governor no later than six months before the beginning of the ensuing program year.

AUTHORITY NOTE: Promulgated in accordance with R.S. 23:2022.

HISTORICAL NOTE: Promulgated by the Department of Labor, Office of Labor, LR 9:334 (May 1983), repealed and repromulgated by the Department of Employment and Training, Office of Labor, LR 17:357 (April 1991), amended by the Department of Labor, Office of Labor, LR 19: (December 1993).

§143. Maintenance of Document

The original documents must be maintained unless prior approval from the recipient has been granted to substitute microfilm or similar methods in lieu thereof.

AUTHORITY NOTE: Promulgated in accordance with R.S. 23:2022.

HISTORICAL NOTE: Promulgated by the Department of Labor, Office of Labor, LR 9:334 (May 1983), repealed and repromulgated by the Department of Employment and Training, Office of Labor, LR 17:357 (April 1991), amended by the Department of Labor, Office of Labor, LR 19: (December 1993).

§145. Modification/Amendment of Service Delivery Area Job Training Plan

A. The approved two-year job training plan may be changed in two ways: by modification and by amendment.

B. A plan modification is a revision of the approved job training plan which requires PIC-CEO approval and is subject to the requirement of Section 104 and 105 of the act. Summaries of plan modifications must be published for public review and comment no later than 80 days prior to the effective date of the modification. In accordance with Section 104(C) a service delivery area must modify its Job Training Plan when one or more of the following occur:

1. a significant change in labor market or other conditions occurs that would have an adverse impact on its performance;
2. change in grant recipient or administrative entity;
3. change in the geographic area served;
4. a change in funding of more than 20 percent of the annual allocation;
5. obligation of Title II allocations for the second year of the two-year plan period;
6. any other factors which require modification shall be at the discretion of the governor;

C. A plan amendment is a minor adjustment to the approved job training plan. There is no publication requirement, however PIC/CEO approval is required. A plan amendment must be submitted via a cover letter explaining the amendment and should be signed by the PIC chairperson and CEO.

AUTHORITY NOTE: Promulgated in accordance with R.S. 23:2022.

HISTORICAL NOTE: Promulgated by the Department of Labor, Office of Labor, LR 9:334 (May 1983), repealed and repromulgated by the Department of Employment and Training, Office of Labor, LR 17:357 (April 1991), amended by the Department of Labor, Office of Labor, LR 19: (December 1993).

§147. Participant Rights and Benefits

Each service delivery area grant recipient and its subrecipients shall inform each participant of his rights and benefits at the time of enrollment into any activity under the act and shall require each participant to sign a statement that he has been advised of his rights and benefits. This signed statement shall become a permanent part of each participant's official record.

AUTHORITY NOTE: Promulgated in accordance with R.S. 23:2022.

HISTORICAL NOTE: Promulgated by the Department of Labor, Office of Labor, LR 9:334 (May 1983), repealed and repromulgated by the Department of Employment and Training, Office of Labor, LR 17:357 (April 1991), amended by the Department of Labor, Office of Labor, LR 19: (December 1993).

§148. Payments to OJT Employers, Training Institutions, and Other Vendors

Payments to On-the-Job Training employers, training institutions and other vendors are allowable and should be made in accordance with applicable sections of the JTPA federal regulations and any procedures established by the recipient.

AUTHORITY NOTE: Promulgated in accordance with R.S. 23:2022.

HISTORICAL NOTE: Promulgated by the Department of Labor, Office of Labor, LR 19: (December 1993).

§149. Grievance Procedure

Each service delivery area grant recipient and its subrecipients shall adopt a procedure for resolving any grievance including those alleging a violation of the act, federal or state regulations, or other agreements under the act. These procedures shall be in compliance with 20 CFR Part 627 Subpart E and shall be made a part of the service delivery area Job Training Plan. All grievance procedures shall provide for the exhaustion of remedies provided therein before appeal to the governor for review.

AUTHORITY NOTE: Promulgated in accordance with R.S. 23:2022.

HISTORICAL NOTE: Promulgated by the Department of Labor, Office of Labor, LR 9:334 (May 1983), repealed and repromulgated by the Department of Employment and Training, Office of Labor, LR 17:357 (April 1991), amended by the Department of Labor, Office of Labor, LR 19: (December 1993).

§151. Non-discrimination Procedure

Service delivery area grant recipients and its subrecipients shall comply with the applicable requirements of 29 CFR 31, 32 and 34.

AUTHORITY NOTE: Promulgated in accordance with R.S. 23:2022.

HISTORICAL NOTE: Promulgated by the Department of Labor, Office of Labor, LR 9:335 (May 1983), repealed and repromulgated by the Department of Employment and Training, Office of Labor, LR 17:357 (April 1991), amended by the Department of Labor, Office of Labor, LR 19: (December 1993).

§153. Participant Supportive Services

Participant supportive services, needs-based payments, cash incentive payments and bonuses to youth enrolled in Title II-C, and financial assistance are allowable and should be made in accordance with applicable sections of the JTPA Federal Regulations and procedures established by the recipient. Needs-based payments shall be determined in accordance with a locally developed formula or procedures.

AUTHORITY NOTE: Promulgated in accordance with R.S. 23:2022.

HISTORICAL NOTE: Promulgated by the Department of Labor, Office of Labor, LR 9:335 (May 1983), repealed and repromulgated by the Department of Employment and Training, Office of Labor, LR 17:357 (April 1991), amended by the Department of Labor, Office of Labor, LR 19: (December 1993).

§155. Conditional Approval of Job Training Plan

In order to expedite program operations the governor may, at his option, grant partial or conditional approval to a service delivery area Job Training Plan. Such approval will spell out the parameters within which the Job Training Plan may operate and the revision necessary for final approval.

AUTHORITY NOTE: Promulgated in accordance with R.S. 23:2022.

HISTORICAL NOTE: Promulgated by the Department of Labor, Office of Labor, LR 9:335 (May 1983), repealed and repromulgated by the Department of Employment and Training, Office of Labor, LR 17:357 (April 1991), repromulgated by the Department of Labor, Office of Labor, LR 19: (December 1993).

§157. Duplication of Services

Repealed.

AUTHORITY NOTE: Promulgated in accordance with R.S. 23:2022.

HISTORICAL NOTE: Promulgated by the Department of Labor, Office of Labor, LR 9:334 (May 1983), repealed and repromulgated by the Department of Employment and Training, Office of Labor, LR 17:357 (April 1991), repealed by the Department of Labor, Office of Labor, LR 19: (December 1993).

§159. Administrative Cost Pooling

Funds for the administration of programs under the act within the service delivery area may be pooled pursuant to §627.440(f) of the regulations.

AUTHORITY NOTE: Promulgated in accordance with R.S. 23:2022.

HISTORICAL NOTE: Promulgated by the Department of Labor, Office of Labor, LR 9:335 (May 1983), repealed and repromulgated by the Department of Employment and Training, Office of Labor, LR 17:357 (April 1991), amended by the Department of Labor, Office of Labor, LR 19: (December 1993).

§161. Statewide Management Information System

Each service delivery area grant recipient will be responsible for maintaining a client tracking and management information system that will interface required data with the Louisiana Department of Labor statewide automated system established for JTPA purposes.

AUTHORITY NOTE: Promulgated in accordance with R.S. 23:2022.

HISTORICAL NOTE: Promulgated by the Department of Labor, Office of Labor, LR 9:335 (May 1983), repealed and repromulgated by the Department of Employment and Training, Office of Labor, LR 17:357 (April 1991), amended by the Department of Labor, Office of Labor, LR 19: (December 1993).

§163. Prevention of Fraud and Program Abuse

A. To ensure integrity of programs under the act, special efforts are necessary to prevent fraud and other program abuses. Fraud includes deceitful practices and intentional misconduct, such as willful misrepresentation in accounting for use of program funds. "Abuse" is a general term which encompasses improper conduct which may or may not be fraudulent in nature. While any violation of the Act or regulations may constitute fraud or program abuse, this rule identifies and addresses specific areas which need clarification.

B. This rule sets forth specific responsibilities of recipients, service delivery area grant recipients and subrecipients to prevent fraud and program abuse in JTPA.

C. Conflict of Interest

1. In addition to the standards set forth below, the State Code of Governmental Ethics contains restrictions concerning conflicts of interest. Any issues regarding the State Code of Governmental Ethics should be brought before the Commission of Ethics for Public Employees.

a. No member of any council under the act shall cast a vote on the provision of services by that member or any

organization which that member directly represents or any matter which would provide direct financial benefit to that member. Caution must be exercised by members to insure that council action does not render the member in violation of R.S. 42:1112, which under certain circumstances may require members to cure the conflict of interest through resignation.

b. Each recipient, service delivery area grant recipient and subrecipients shall avoid personal conflict of interest and appearance of conflict of interest in awarding financial assistance and in the conduct of procurement activities involving funds under the act.

c. Neither the recipient, any service delivery area grant recipient nor subrecipients shall pay funds under the act to any individual, institution, or organization to conduct an evaluation of any program under the act if such individual, institution, or organization is associated with that program as a consultant or technical advisor.

D. Kickbacks. No officer, employee, or agent of the recipient, service delivery area grant recipient or subrecipients shall solicit or accept gratuities, favors, or anything of monetary value from any actual or potential subrecipient.

E. Commingling of Funds. The recipient, service delivery area grant recipients and subrecipients shall comply with the applicable requirements of 29 CFR 97.21(h) and R.S. 49:321.

F. Nepotism. The State Code of Governmental Ethics contains restrictions against the hiring of certain family members. Questions regarding the hiring of family members should be referred to the Commission on Ethics for Public Employees.

G. Child Labor. The recipient, service delivery area grant recipients and subrecipients shall comply with applicable federal, state and local child labor laws.

H. Political Patronage

1. Neither the recipient, service delivery area grant recipients, nor any subrecipients may select, reject, or promote a participant based on that individual's political affiliation or beliefs. The selection or advancement of employees as a reward for political services or as a form of political patronage whether or not political services is partisan in nature, is prohibited.

2. There shall be no selection of subrecipients based on political patronage or affiliation.

I. Political Activities

1. No program under the act may involve political activities, including but not limited to:

a. No participant may engage in partisan or non-partisan political activities during hours for which the participant is paid with JTPA funds;

b. No participant may, at any time, engage in partisan political activities in which such participant represents himself/herself as spokesperson of the JTPA program;

c. No participant may be employed or outstationed in the office of a member of Congress or a state or local legislator or on any staff of a legislative committee;

d. No participant may be employed or outstationed in positions involving political activities in the offices of other elected executive officials. However, since under the responsibility of such elected officials are non-political activities, placement of participants in such non-political

positions is permissible. Service delivery area grant recipients and subrecipients shall develop safeguards to ensure that participants placed in these positions are not involved in political activities. These safeguards will be subject to review and monitoring.

2. Persons governed by Chapter 15 of Title 5, United States Code, the Hatch Act, shall comply with its provisions as interpreted by the United States Office of Personnel Management. These provisions apply:

a. to persons (including participants) employed by state and local government in the administration of the JTPA program; and

b. generally to any participant whose principal employment is in connection with an activity financed by other federal grants or loans.

J. Lobbying Activities. No funds provided under the Act may be used in any way:

1. to attempt to influence in any manner a member of Congress to favor or oppose any legislation or appropriation by Congress;

2. to attempt to influence in any manner state or local legislators to favor or oppose any legislation or appropriation by such legislators. Communications and consultation with state and local legislators for purposes of providing information such as on matters necessary to provide compliance with the Act shall not be considered lobbying.

K. Sectarian Activities. The Act provides the following prohibitions regarding sectarian activity:

1. participants shall not be employed on the construction, operation or maintenance of so much of any facility as is used or to be used for sectarian instruction or as a place for religious worship; and

2. participants shall not be involved, nor JTPA funds expended, for religious or anti-religious activities.

L. Unionization and Antiunionization Activities/Work Stoppages

1. No funds under the act shall be used in any way to assist, promote or oppose unionization.

2. No individual shall be required to join a union as a condition for enrollment in a program in which only institutional training is provided, unless such institutional training involves individuals employed under a collective bargaining agreement which contains a union security provision.

3. No participant in work experience may be placed into, or remain working in any position which is affected by labor disputes involving a work stoppage. If such a work stoppage occurs during the grant period, participants in affected positions must:

a. be relocated to positions not affected by the dispute;

b. be suspended through administrative leave; and

c. where participants belong to the labor union involved in the work stoppage, be treated in the same manner as any other union member except such members must not remain working in the affected position. The grantee shall make every effort to relocate participants, who wish to remain working, into suitable positions unaffected by the work stoppage.

4. No person shall be referred to or placed in an

on-the-job training position affected by a labor dispute involving a work stoppage and no payments may be made to employers for the training and employment of participants in on-the-job training during the periods of work stoppage.

5. Nothing in this Section shall prevent an employer from checking off union dues or service fees pursuant to applicable collective bargaining agreements or state law.

6. No currently employed worker shall be displaced by any participant (including partial displacement such as a reduction in the hours of nonovertime work, wages, or employment benefits).

7. No program under this act shall impair existing contracts for services or existing collective bargaining agreements, unless the employer and the labor organization concur in writing with respect to any elements of the proposed activities which affect such agreement, or either such party fails to respond to written notification requesting its concurrence within 30 days of receipt thereof.

8. No participant shall be employed or job openings filled when any other individual is on layoff from the same or any substantially equivalent job, or when the employer has terminated the employment of any regular employee or otherwise reduced its workforce with the intention of filling the vacancy so created by hiring a participant whose wages are subsidized under this Act.

9. No jobs shall be created in a promotional line that will infringe in any way upon the promotional opportunities of currently employed individuals.

M. Maintenance of Effort

1. To ensure maintenance of effort under all programs under the act, the recipient, service delivery area grant recipients and subrecipients shall ensure that such programs:

a. result in an increase in employment and training opportunities over those which would otherwise be available;

b. do not result in the displacement of currently employed workers including partial displacement, such as reduction in hours of nonovertime work, wages, or employment benefits;

c. do not impair existing contracts for services or result in the substitution of federal funds for other funds in connection with work that would otherwise be performed including services normally provided by temporary, part-time or seasonal workers or through contracting such services out; and

d. result in the creation of jobs that are in addition to those that would be funded in the absence of assistance under the act.

2. Funds under this act shall supplement, and not supplant, the level of funds that would otherwise be made available from non-federal sources for the planning and administration of programs.

N. Responsibilities of Service Delivery Area Grant Recipients and Subrecipients for Preventing Fraud and Program Abuse and for General Program Management General Requirements. Each service delivery area grant recipient and subrecipients shall establish and use internal program management procedures sufficient to prevent fraud and program abuse.

AUTHORITY NOTE: Promulgated in accordance with R.S. 23:2022.

HISTORICAL NOTE: Promulgated by the Department of Labor, Office of Labor, LR 9:335 (May 1983), repealed and repromulgated by the Department of Employment and Training, Office of Labor, LR 17:357 (April 1991), amended by the Department of Labor, Office of Labor, LR 19: (December 1993).

§165. Governor's Responsibility

The governor or his designee reserves the right to issue directives, instructions, or other issuances to the Service Delivery Area (SDA) grant recipients, administrative entities and other subrecipients in order to carry out his responsibility as required by the act.

AUTHORITY NOTE: Promulgated in accordance with R.S. 23:2022.

HISTORICAL NOTE: Promulgated by the Department of Labor, Office of Labor, LR 10:456 (July 1984), repealed and repromulgated by the Department of Employment and Training, Office of Labor, LR 17:357 (April 1991), repromulgated by the Department of Labor, Office of Labor, LR 19: (December 1993).

§167. CETA Property

All existing nonexpendable Comprehensive Employment and Training Act (CETA) property with an acquisition cost of less than \$1,000 per unit may be used by the possessing recipient, SDA grant recipient, administrative entity, or state agency holding title, to satisfy the matching requirements of the act in accordance with the definition of "Matching Funds for Eight Percent Programs" found in §101 of these rules.

AUTHORITY NOTE: Promulgated in accordance with R.S. 23:2022.

HISTORICAL NOTE: Promulgated by the Department of Labor, Office of Labor, LR 10:456 (July 1984), repealed and repromulgated by the Department of Employment and Training, Office of Labor, LR 17:357 (April 1991), amended by the Department of Labor, Office of Labor, LR 19: (December 1993).

§169. Occupational Demand

A. Except as otherwise provided, training provided with funds made available under this act shall be only for occupations for which there is a demand in the area served, or in other areas to which the participant is willing to relocate.

B. All contracts that are being funded by JTPA money where the intent of the contract is placement shall have performance goals including placement goals incorporated in that contract unless otherwise specified by the council.

AUTHORITY NOTE: Promulgated in accordance with R.S. 23:2022.

HISTORICAL NOTE: Promulgated by the Department of Labor, Office of Labor, LR 10:917 (November 1984), repealed and repromulgated by the Department of Employment and Training, Office of Labor, LR 17:357 (April 1991), repromulgated by the Department of Labor, Office of Labor, LR 19: (December 1993).

§171. Labor Organizations

Where a labor organization represents a substantial number of employees who are engaged in similar work or training in the same area as that proposed to be funded under this act, an opportunity shall be provided for such organization to submit comments with respect to such proposals.

AUTHORITY NOTE: Promulgated in accordance with R.S. 23:2022.

HISTORICAL NOTE: Promulgated by the Department of Labor, Office of Labor, LR 10:917 (November 1984), repealed and

repromulgated by the Department of Employment and Training, Office of Labor, LR 17:357 (April 1991), amended by the Department of Labor, Office of Labor, LR 19: (December 1993).

§173. Deadlines

Not less than 120 days before the beginning of the first of the two program years covered by the JTPA Plan:

1. the proposed plan or summary thereof shall be published; and

2. such plan shall be made available for review and comment to:

a. each house of the Legislature;

b. local educational and public agencies; and

c. the labor organization in the area which represents employees having the skills in which training is proposed.

AUTHORITY NOTE: Promulgated in accordance with R.S. 23:2022.

HISTORICAL NOTE: Promulgated by the Department of Labor, Office of Labor, LR 10:917 (November 1984), repealed and repromulgated by the Department of Employment and Training, Office of Labor, LR 17:357 (April 1991), amended by the Department of Labor, Office of Labor, LR 19: (December 1993).

Gayle F. Truly
Secretary

RULE

Department of Labor Plumbing Board

Licensing and Renewal Fee Changes (LAC 46:LV.Chapter 3)

In accordance with the Administrative Procedure Act, R.S. 49:50 et seq., the Plumbing Board amended its regulations to comply with Act No. 43 of 1993, which relates to the licensing of master plumbers. The rule also enacts adjustments in master plumber licensing and renewal fees. The board is empowered to adopt such regulations by R.S. 37:1366(D).

The rule changes are as follows:

Title 46

PROFESSIONAL AND OCCUPATIONAL STANDARDS

Part LV. Plumbers

Chapter 3. Licenses

§301. Licenses Required

A. - C. ...

D. No natural person shall engage in the work of a master plumber unless he possesses a master plumber's license or renewal thereof issued by the board. The board shall issue a master plumber license to any person who qualifies under the board's regulations and who desires to engage in doing the work of a master plumber if he passes a written examination given by the board and pays the fees established by the board. A written examination shall not be required for persons applying pursuant to §301.I and §303.C. A master

plumber shall not engage in the work of a journeyman plumber unless he also possesses a journeyman plumber's license issued by the board or previously possessed a journeyman plumber's license issued by the board. A person issued a master plumber's license shall designate to the board, as required by the rules of the board, an employing entity, which may be a corporation, partnership, or sole proprietorship. A licensed master plumber shall notify the board of any change of employment status with an employing entity within 30 days of the effective date of change in employment status. A master plumber shall designate no more than one employing entity at any time. The board may charge a reasonable fee for processing such redesignations.

* * *

I. A restricted master plumber license, as permitted by R.S. 37:1368(C) and (D), shall be issued by the board to any natural person who, prior to July 1, 1990, possessed a master plumber license issued by a local governmental jurisdiction or to a journeyman plumber licensed by this board who was permitted by local law to conduct a plumbing business in a local governmental jurisdiction as an employing entity. Any person holding a restricted master plumber's license shall not perform the work of a journeyman plumber unless he currently possesses or previously possessed a journeyman plumber's license issued by the board. This restricted master plumber license shall permit the license holder to perform the work and business of plumbing only in the geographic area previously covered by the local governmental authority and only within the scope of plumbing work or business permitted by such local license or local law. Any employing entity designated by a restricted master plumber shall likewise be limited to the conduct of its plumbing business to the geographic area and scope of plumbing work or business described in the license issued to the restricted master plumber.

J. An inactive master plumber, as that term is used in R.S. 37:1368(E), shall mean a natural person who is licensed by the board as a master plumber or who successfully applies for and passes the examination for master plumber license administered by the board pursuant to §305 of these rules. An applicant for inactive master plumber status must state in a form supplied by the board that he does not wish or intend to practice as a master plumber. An inactive master plumber shall not be permitted to designate an employing entity, or knowingly allow an employing entity to hold itself out as employing him as a master plumber. An inactive master plumber can convert his status to that of a master plumber by submitting to the board an appropriate form supplied by the board and upon payment of a fee established by the board. During the period of his inactive status the inactive master plumber shall pay a fee established by the board. An inactive master plumber converting his status under this Section shall designate an employing entity. Persons issued a restricted master plumber license under §301.I of these rules shall likewise be permitted to apply for inactive master plumbing status. However, should that person convert his status to that of master plumber such converted status shall be subject to the same restrictions applicable to his original restricted license. An inactive master plumber shall be permitted to

work as a journeyman plumber during the period or periods he maintains an inactive plumber's license, if he is currently or was previously licensed by the board as a journeyman plumber.

AUTHORITY NOTE: Adopted in accordance with R.S. 37:1377 and R.S. 37:1366.

HISTORICAL NOTE: Adopted by the Department of Labor, Plumbing Board, 1968, repromulgated as amended, by Department of Employment and Training, Plumbing Board, LR 17:49 (January 1991), amended by the Department of Labor, Plumbing Board, LR 19: (December 1993).

§309. Fees

A. ...

B. The fees and charges of the board relative to master plumbers, restricted master plumbers and inactive master plumbers shall be as follows:

- 1. - 2. ...
- 3. Initial license fee \$180
- 4. Renewal fee \$180
- 5. Revival fee \$ 60
- (If renewed after March 31st) \$120
- 6. - 9. ...
- 10. Fee for conversion of inactive master plumber license to active master plumber \$150

* * *

AUTHORITY NOTE: Promulgated in accordance with R.S. 37:1366 and R.S. 37:1377.

HISTORICAL NOTE: Promulgated by the Department of Labor, Plumbing Board, 1968, amended by the Department of Employment and Training, LR 17:53 (January 1991), amended by Department of Labor, Plumbing Board, LR 19: (December 1993).

Don Traylor
Executive Director

RULE

**Department of Revenue and Taxation
Office of the Secretary**

Timely Filing Date (LAC 61:I.4903)

In accordance with R.S. 49:950 et seq. of the Administrative Procedure Act, the Department of Revenue and Taxation, Office of the Secretary has adopted the following rule concerning the timely filing date when the due date of a report or return falls on a Saturday, Sunday, or legal holiday as authorized by R.S. 9:188, 26:453, 45:1179, 47:1511, and 47:2425.

The individual income tax and corporation income and franchise tax statutes specify that the timely filing date when the due date falls on a weekend or holiday is the next business day. Other tax statutes do not specify the timely filing date in these instances; for some taxes it is deemed to be the last work day prior to the weekend or holiday and for others it is the following day. This rule establishes consistency for all taxes in determining delinquencies and assessing interest and penalties.

Title 61

REVENUE AND TAXATION

**Part I. Taxes Collected and Administered by the
Secretary of Revenue and Taxation**

Chapter 49. Tax Collection

**§4903. Timely Filing when the Due Date Falls on
Saturday, Sunday, or Legal Holiday**

A. Unless otherwise specifically provided, when the due date of any report or return prescribed under the laws administered by the Department of Revenue and Taxation, falls on a Saturday, Sunday, or a legal holiday, the report or return shall be considered timely if it is filed on the next business day.

B. Definitions. For the purposes of this Section, the following terms are defined:

Legal Holiday—any legal holiday observed by the State of Louisiana or the United States Post Office.

AUTHORITY NOTE: Promulgated in accordance with R.S. 9:188, 26:453, 45:1179, 47:1511, and 47:2425.

HISTORICAL NOTE: Promulgated by the Department of Revenue and Taxation, Office of the Secretary, LR 19: (December 1993).

Ralph Slaughter
Secretary

RULE

**Department of Transportation and Development
Office of General Counsel
Crescent City Connection Division**

Toll Exemptions—Firemen (LAC 70:I.507)

In accordance with the applicable provisions of the Administrative Procedure Act. R.S. 49:950 et seq., the Department of Transportation and Development has adopted a rule entitled Crescent City Connection - Exemptions from Tolls-Firemen, in accordance with R.S. 33:1975.

Title 70

TRANSPORTATION

Part I. Office of General Counsel

Chapter 5. Tolls

§507. Crescent City Connection Exemptions-Firemen

A. Purpose. All firemen, volunteer firemen shall have free and unhampered passage on and over the Crescent City Connection bridges, the Gretna/Jackson Avenue ferry, the Algiers/Canal Street ferry and the Lower Algiers/Chalmette ferry.

B. Procedure for Firemen

1. All firemen as defined in R.S. 39:191(A) shall present an identification card containing a photographic picture of the fireman for inspection by the toll collector. The identification card must be issued by the municipality, parish or district as referred to in R.S. 39:191(A).

2. All firemen shall sign a register at the toll booth or station, and provide the name of agency, municipality, parish or district for which they are employed or engaged.

3. After compliance with Paragraphs 1 and 2 above, free and unhampered passage will be granted to the fireman.

C. Procedure for Volunteer Firemen

1. All volunteer fire organizations shall apply to the Crescent City Connection Division and shall certify to the following:

a. the address of the volunteer fire organization's domicile or headquarters;

b. the general location served by the volunteer fire organization;

c. that the members of the volunteer fire organization are required to travel across the facilities, stated in the above paragraph pertaining to purpose, in the performance of official fire fighting or fire prevention services;

d. the number of crossings made in one year, on the facilities stated in the Subsection A above pertaining to purpose, by volunteer firemen members of the volunteer fire organization.

2. The application must be signed by the chief executive officer of the volunteer fire organization.

3. Vehicle Passes

a. Upon approval of an application, the Crescent City Connection Division shall issue vehicle passes for use by the volunteer firemen members of the volunteer fire organization.

b. The vehicle passes shall be for the exclusive use of volunteer firemen members of the volunteer fire organization, while operating a motor vehicle, and are not transferable.

c. The vehicle passes shall not be used for any other purpose than crossing the bridges or ferries for the performance of official firefighting or fire prevention services by volunteer firemen.

d. Lost, stolen or damaged passes will not be replaced.

4. Loss of Privilege. Any prohibited use of vehicle passes issued to a volunteer fire organization will result in the loss of the privilege to obtain and use passes and/or action provided by law.

AUTHORITY NOTE: Promulgated in accordance with R.S. 33:1975.

HISTORICAL NOTE: Promulgated by the Department of Transportation and Development, Office of General Counsel, LR 19: (December 1993).

Jude W.P. Patin
Secretary

RULE

**Department of Transportation and Development
Office of the General Counsel
Crescent City Connection Division**

Toll Exemption—Students (LAC 70:I.509)

In accordance with the applicable provisions of the Administrative Procedure Act, R.S. 49:950, et seq., the Department of Transportation and Development has adopted

a rule entitled "Crescent City Connection—Exemption from Tolls—Students," in accordance with Act 345 of 1993 (R.S. 17:157).

Title 70

TRANSPORTATION

Part I. Office of the General Counsel

Chapter 5. Tolls

§509. Crescent City Connection Exemptions-Students

A. Purpose. In addition to free passage of students in clearly marked school buses as is now provided, any motorized vehicle operated by a student attending a school, which includes universities, colleges, and secondary schools, shall have free passage over the Crescent City Connection bridges, the Gretna/Jackson Avenue ferry, the Algiers/Canal Street ferry, and the Lower Algiers/Chalmette ferry, during the hours of 6 a.m. through 9:30 a.m., and 2:30 p.m. through 9:30 p.m., for traveling to and from school.

B. Application

1. Students who are majors, or in the case of a minor student, the legal parent or guardian, shall apply to the Crescent City Connection Division for each student for each school year, and shall certify as to the following:

a. the address of the student's domicile;

b. the address of the school attended by the student;

c. the student regularly operates a private vehicle to travel to and from school;

d. the geographic location of the school in relation to the student's domicile requires travel across the facilities stated in the above paragraph pertaining to "Purpose."

2. The appropriate school official, the registrar of the college or university attended by the student, or the principal, headmaster, or administrator of the school attended by the student, shall certify on the application as to the enrollment of the student at the school and the length of the school year.

C. Vehicle Passes

1. Upon approval of an application, the Crescent City Connection Division shall issue vehicle passes for use by the student.

2. The vehicle passes shall be for the personal use of the student, while operating a motor vehicle, and are not transferable.

3. The vehicle passes shall not be used for any other purpose than crossing the bridges or ferries for required attendance at school.

4. Lost, stolen, or damaged passes will not be replaced.

D. Loss of Privilege. Any prohibited use of Student Vehicle Passes will result in the loss of the privilege to obtain and use passes and/or actions provided by law.

AUTHORITY NOTE: Promulgated in accordance with Act 345 of the 1993 Session of the Louisiana Legislature, R.S. 17:157(A).

HISTORICAL NOTE: Promulgated by the Department of Transportation and Development, LR 19: (December 1993).

Jude W. P. Patin
Secretary

RULE

Department of Transportation and Development Office of the Secretary Public Transportation Section

Tourist Oriented Directional Signs (LAC 70:III.Chapter 2)

In accordance with the applicable provisions of the Administrative Procedure Act, R.S. 49:950, et seq., the Department of Transportation and Development has adopted the following rule entitled "Installation of Tourist Orientation Directional Signs", in accordance with the provisions of R.S. 48:461.2.

Title 70

TRANSPORTATION

Part III. Highways/Engineering

Chapter 2. Installation of Tourist Oriented Directional Signs (TODS)

§201. Purpose

The purpose of this directive is to establish policies for the installation of Tourist Oriented Directional Signs (TODS) within state highway rights-of-way.

AUTHORITY NOTE: Promulgated in accordance with R.S. 48:461.2.

HISTORICAL NOTE: Promulgated by the Department of Transportation and Development, LR 19: (December 1993).

§203. Definitions

A. Except as defined in this paragraph, the terms used in this directive shall be defined in accordance with the definitions and usage of the Louisiana Manual on Uniform Traffic Control Devices (MUTCD).

Conventional Highway—any state-maintained highway other than interstate.

Department—all references to "department" shall be interpreted to mean Louisiana Department of Transportation and Development.

Local Road—any roadway which is not part of the state-maintained system.

Tourist Activities—publicly or privately owned or operated; natural phenomena, historic, cultural, scientific, educational, or religious sites, and areas of national beauty or areas naturally suited for outdoor recreation, as well as all associated business services, deemed to be in the interest of the traveling public, "the major portion of whose income or visitors are derived during the normal business season from motorists not residing in the immediate area of the activity."

Tourist Oriented Directional Signs (TODS)—official signing located within the state rights-of-way giving specific directional information regarding tourist activities.

AUTHORITY NOTE: Promulgated in accordance with R.S. 48:461.2.

HISTORICAL NOTE: Promulgated by the Department of Transportation and Development, LR 19: (December 1993).

§205. General Eligibility Requirements

A. General

Tourist activities shall be open to all persons regardless of race, color, religion, ancestry, national origin, sex, age or handicap; be neat, clean and pleasing in appearance;

maintained in good repair; and comply with all federal, state, and local regulations for public accommodations concerning health, sanitation, safety, and access.

B. Examples

1. Typical attractions which may qualify as a tourist activity are:

a. national historical sites, parks, cemeteries, monuments;

b. state historical sites, parks, monuments; cultural attractions;

c. aquariums, museums, zoos, planetariums, and arboretums;

d. lakes and dams, recreational areas, beaches;

e. Indian sites, historical homes/buildings, gift/souvenir shops.

C. Admission Charges

If general admission is charged, charges shall be clearly displayed so as to be apparent to prospective visitors at the place of entry.

D. Parking

Off-street parking for a minimum of 15 cars, but adequate to handle the demand.

E. Minimum Attendance

Attendance at the attraction will be a factor for signage and will be considered in conjunction with other factors such as intrinsic significance with preference given to facilities with the greatest annual attendance.

F. Hours

Tourist activities shall maintain regular hours and schedules and be open to the public at least five days each week and a minimum of eight months of the year.

G. Illegal Signs

TOD sign applications will not be accepted if the tourist activity has any illegal advertising signs on or along any state highway.

H. Insufficient Space

Preference will always be given to the erection of standard traffic signs (e.g., regulatory, warning, and guide signs) which may preclude the authorization of TODS since a space of 200 feet is required between all signs on conventional roads.

I. On-Premise Sign

The tourist activity shall have on-premise sign identifying the name of the facility. If the attraction's on-premise sign is readily visible from the highway, a TOD sign is not normally required in front of the attraction.

J. Trailblazing

Trailblazing needs will be determined by the department. The activity must provide all trailblazing signs on local roads.

K. Return in Same Direction of Travel

TOD signs will not be authorized for facilities if motorists cannot readily return to the highway in the same direction of travel.

L. Direction to Freeways

TOD signs will not be authorized to direct traffic onto a freeway or expressway.

M. Sign Design. TOD signs will be designed in accordance with Figure No. 1 and as follows:

1. Each sign should have one or two lines of legend. All signs shall have directional arrow with mileage. If the distance to the attraction is over 1/2 mile, the distance to the attraction to the nearest whole mile shall be included below the arrow. The content of the legend shall be limited to the name of the attraction and the directional information. If space exists on the second line, additional directional information may be indicated, e.g., 1/4 mile on left, left on 2nd Street, etc. The maximum number of letters and spaces on a given line will be about 18. Legends shall not include promotional advertising.

2. The standard sign will be 72" X 18" for conventional roads and 48" x 12" for trailblazers. Letters, numbers, and arrows are to conform to the provisions in the Louisiana Manual on Uniform Traffic Control Devices and detailed drawings in the Standard Highway Signs book.

3. TODS shall have white reflectorized legend and borders on a blue reflectorized background, except that a brown reflectorized background may be used for attraction signs for state and national parks or recreational areas, and for historical sites.

AUTHORITY NOTE: Promulgated in accordance with R.S. 48:461.2.

HISTORICAL NOTE: Promulgated by the Department of Transportation and Development, LR 19: (December 1993).

§207. Location and Number of TODS on Conventional Highways

A. General

On conventional highways, TODS may be authorized for eligible attractions, directing motorists from the nearest Arterial Highway from each approach to the attraction for a distance not to exceed 15 road miles.

B. Sign Location

Sign assemblies should be placed far enough in advance of the intersection to allow time for the necessary maneuver. A minimum of 200 feet should be maintained between all signs. (See Figure 2)

C. Maximum Number of Signs

A maximum of six attractions will be authorized for signs on any approach to an intersection.

D. Sign Assemblies

1. TOD signs should normally be installed as independent sign assemblies as follows:

a. Signs shall be installed on one sign assembly with the signs with arrows pointing to the left above those pointing to the right. If any straight ahead arrows are authorized, as in the case where the road turns and the attraction's access is straight ahead, the sign for that attraction shall be installed above any signs for attractions to the left or right.

b. If more than six attractions qualify at a given location priority will be given to the closest attraction. Once an attraction has been signed it has priority over subsequent attractions which are closer.

c. If more than one attraction exists in a given direction, the signs for the closer attraction should be above the more distant attractions.

AUTHORITY NOTE: Promulgated in accordance with R.S. 48:461.2.

HISTORICAL NOTE: Promulgated by the Department of Transportation and Development, LR 19: (December 1993).

§209. Application Procedure

A. Application for TODS shall be submitted to LA DOTD Traffic Engineering and Safety Section.

B. Personnel assigned to this office will review the application and a field check will be made by the District Traffic Operations Engineer to verify information provided and to collect additional data on existing conditions, including whether a location for a TODS exist at the requested intersection and what trailblazing will be necessary.

C. The Louisiana Department of Transportation and Development shall then forward the requests with information to the Louisiana Tourist Development Commission.

D. The Louisiana Tourist Development Commission will determine if the applicant qualifies as a tourist activity and make a report of its finding to the department.

E. If a request is approved, LA DOTD shall:

1. Design the TOD sign and furnish a drawing of it to the applicant with a statement of fabrication and installation charges, and an estimate of the time when installation will occur after payment of the charges. The department will determine the date of an installation, in its sole discretion, based on the conditions at the intersection involved and the availability of resources to install a sign assembly.

2. Collect from the applicant the cost of sign fabrication and installation.

3. The District Traffic Operations Engineer will then check for the necessary trailblazing on local roads. If they are in place and in satisfactory condition, the TOD signs will be installed. If the facility fails to meet qualifications or ceases to exist, their sign will be removed. The field personnel will also have the responsibility to remove TOD signs for seasonal activities.

AUTHORITY NOTE: Promulgated in accordance with R.S. 48:461.2.

HISTORICAL NOTE: Promulgated by the Department of Transportation and Development, LR 19: (December 1993).

§211. Fees and Agreements

A. The annual fee and service fee charges for each TOD sign shall be established by the department as stipulated on the permit application. Notification will be given 30 days prior to changes in service fee charges. Publicly operated facilities will be exempted from all fees.

1. The annual renewal date shall be January 1. The permittee will be invoiced for renewal, 30 days prior to the renewal date. The fee shall be remitted by check or money order payable to the Louisiana Department of Transportation and Development. Failure of a business to submit the renewal fee(s) by the annual renewal date shall be cause for removal and disposal of the TOD signs by the department. The initial fee shall be prorated by the department to the annual renewal date to cover the period beginning with the month following the installation of the TOD signs. Service fees will be charged for the removal and reinstallation of delinquent applicants.

2. When requested by the applicant, the department at its convenience may perform additional requested services in connection with changes of the TOD sign, with a service charge per sign. A service fee will be charged for removal and reinstallation of seasonal signs.

3. The department shall not be responsible for damages to TOD signs caused by acts of vandalism, accidents, natural causes (including natural deterioration), etc. requiring repair or replacement. Applicants will be assessed a service charge per sign payable to the department, to replace such damaged sign(s).

4. Tourist attractions requesting placement of TOD signs shall submit to the department a completed application form provided by the department. The required service charges for fabrication and installation must be submitted prior to commencing work.

5. No TOD sign shall be displayed which, in the opinion of the department, does not conform to department standards, is unsightly, badly faded, or in a substantial state of dilapidation. The department shall remove or replace any such TOD signs as appropriate. Removal shall be performed upon failure to pay any fee or for violation of any provision of these rules.

6. When a TOD sign is removed, it will be taken to the District Office of the district in which the activity is located. The applicant will be notified of such removal and given 30 days in which to pay the fees.

7. Should the department determine that trailblazing to a tourist attraction is desirable, it shall be done with an assembly (or series of assemblies) consisting of signs and an appropriate white on blue arrow, or an acceptable alternate. The department will fabricate the signs at permit cost, and the attraction will be responsible for installing the signs on all local roads.

8. Should an attraction qualify for TOD signs at two locations, the TOD sign(s) will be erected at the nearest location. If the applicant desires signing at the other location also, it may be so signed provided it does not prevent another attraction from being signed.

9. When it comes to the attention of the department that a participating activity is not in compliance with the minimum criteria, the applicant will be notified that it has a maximum of 30 days to correct any deficiencies or its signs will be removed. If the applicant applies for reinstatement, this request will be handled in the same manner as a request from a new applicant.

10. The department reserves the right to cover or remove any or all TOD signs in the conduct of its operations or whenever deemed to be in the best interest of the department or the traveling public without advance notice thereof. The department reserves the right to terminate this program or any portion thereof by furnishing the applicant, a written notice of such intent not less than 30 calendar days prior thereof.

AUTHORITY NOTE: Promulgated in accordance with R.S. 48:461.2.

HISTORICAL NOTE: Promulgated by the Department of Transportation and Development, LR 19: (December 1993).

§213. Other Issuances Affected

All directives, memoranda or instructions issued heretofore that conflict with this rule are hereby rescinded. All existing supplemental guide signs which qualify under this rule, but are not TODS, shall be removed, and replaced with TODS within two years in accordance with these procedures.

Tourist Oriented Directional Signs (TODS)

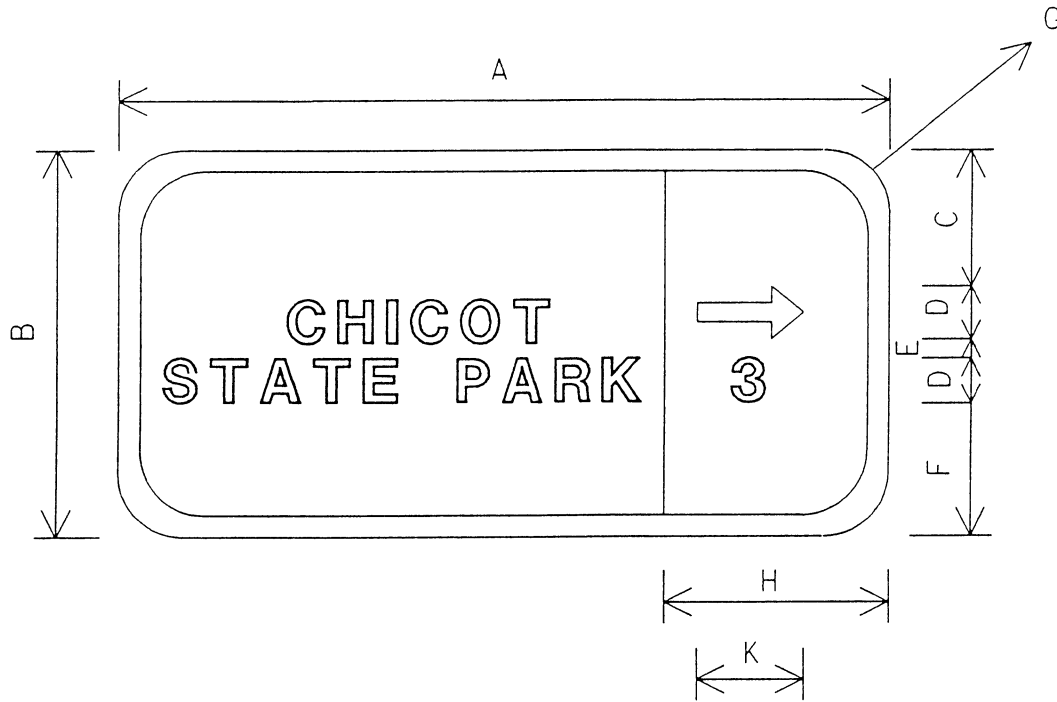

	SIGN SIZE	DIMENSIONS									BORDER
		A	B	C	D	E	F	G	H	K	
Trail Blazer	48X12	48	12	1	4C	1½	1½	1½	8	6	½
ARTERIALS	72X18	72	18	2	6B	2	2	1½	10	8	¾

COLOR: Legend and Border: White
 Background: Blue or Brown

Figure 1

Typical Signing for Conventional Highways

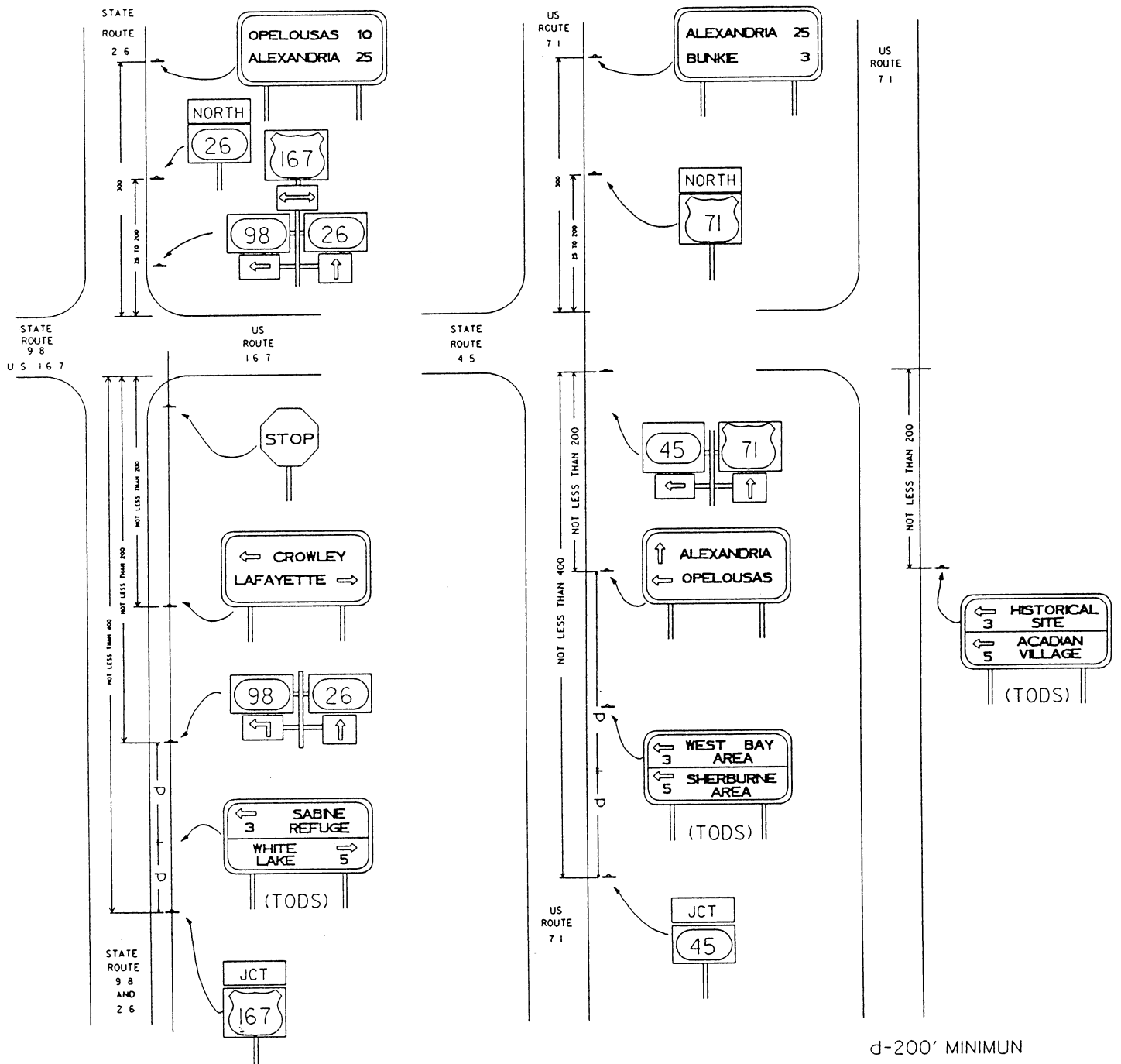

d-200' MINIMUM

TODS - Tourist Oriented
Directional Signs

Figure 2

APPLICATION FOR
TOURIST ORIENTED DIRECTIONAL SIGNS (TODS)

RULE

Department of Treasury
Board of Trustees of the Teachers' Retirement System

Deferred Retirement Option Plan (DROP)

The Department of the Treasury, Board of Trustees of the Teachers' Retirement System, pursuant to the Notice of Intent published on pages 1257-1258 of the September, 1993 *Louisiana Register*, and under authority contained in R.S.11:702, 11:761, 11:783 and 11:786-11:791 amended the Policies for Implementation of the Deferred Retirement Option Plan, to become effective January 1, 1994, as follows:

1. Members of the Teachers' Retirement System of Louisiana (TRSL), in lieu of terminating employment and accepting a retirement allowance, may elect to participate in the Deferred Retirement Option Plan (DROP) in accordance with R.S. 11:786-11:791 when the following eligibility requirements for plan participation are met.

a. Regular Plan members:

- 30 years of service credit at any age;
- 25 years of service credit and at least age 55;
- 20 years of service credit and at least age 65

(excluding military service); and

- 10 years of service credit and at least age 60

(excluding military service).

Those members with 10 years of service credit and who are at least age 60 will have retirement benefits calculated using a two percent benefit formula.

b. School Food Service Plan A members:

- 30 years of service credit at any age;
- 25 years of service credit and at least age 55; and
- 10 years of service credit and at least age 60

(excluding military service).

c. School Food Service Plan B members:

- 30 years of service credit and at least age 55; and
- 10 years of service credit and at least age 60

(excluding military service).

2. DROP participation may begin or end any day of the month. The effective date for participation in DROP will be the date a properly executed DROP application, including the designation of a DROP account beneficiary(ies), is filed in the office of TRSL or the stated effective date on the properly executed DROP application, whichever is later. In the event an employer fails to submit the application in a timely fashion the provisions of R.S. 11:761 shall apply.

* * *

5. Participation in DROP may not exceed a period of three consecutive years. In order to participate for the maximum three consecutive years, the member must begin DROP participation within 60 calendar days after the first possible eligibility requirement for participation is met (refer to policy one above). The participation period must end not more than three years and 60 calendar days from the date the member first became eligible to participate. The participation period may only be shortened by the participant's termination of employment or death.

Date _____

Facility Name _____

Street Address/Highway No. _____

Nearest Town/Community _____ Parish _____

Annual Attendance _____

Operation: Months _____ Days _____ Hours _____

Description of Attraction (Enclose brochure or pictures) _____

Type of Facility: (Type of qualifying attraction)

<input type="checkbox"/> Amusement Park	<input type="checkbox"/> Cemetery	<input type="checkbox"/> Cultural Center
<input type="checkbox"/> Educational Center	<input type="checkbox"/> Information Center	<input type="checkbox"/> Wildlife Refuge
<input type="checkbox"/> Historical Site	<input type="checkbox"/> Museum	<input type="checkbox"/> Recreation Area
<input type="checkbox"/> National/State Park	<input type="checkbox"/> Religious Site	<input type="checkbox"/> Scenic Site
<input type="checkbox"/> Zoological Park	<input type="checkbox"/> Botanical Park	<input type="checkbox"/> Other

Please note: (1) A map or sketch showing the location of the attraction and the proposed sign locations must accompany this application. (2) Submit application to LA DOTD, Traffic Engineering and Safety Section, P.O. Box 94245, Baton Rouge, LA. 70804-9245

I understand agree to pay the costs of sign fabrication and installation, as well as, replacement and annual renewal fees if this application is approved.

Cost of typical installation: (Per Sign)

Conventional Highway:

	Fab. & Instl.	Annual Fee	Service Fee
Arterial Highway	\$ 75.00	\$ 37.50	\$50.00
Trailblazer	\$ 50.00	\$ 25.00	\$50.00

Applicant Signature: _____

Name (Print): _____ Date: _____

Recommended for Approval: Signed: _____

(District Traffic Operations Engineer) Date: _____

Recommended for Approval: Signed: _____

(Tourist Commission) Title: _____

Date: _____

Approved by: _____

Title: STATE TRAFFIC ENGINEER Date: _____

AUTHORITY NOTE: Promulgated in accordance with R.S. 48:461.2.

HISTORICAL NOTE: Promulgated by the Department of Transportation and Development, LR 19: (December 1993).

Jude W. P. Patin
Secretary

In lieu of a participation period not to exceed the remainder of the three consecutive year period from date of first eligibility, a member who became eligible for DROP on or before January 1, 1994, may, at any time, select a participation period which may not exceed two consecutive years.

6. Retirement benefits shall begin on the first day of the month immediately following termination of DROP in all of the following cases:

- a. voluntary termination (the participant, for any reason, elects to withdraw from DROP prior to completing the selected participation period and also terminates employment);
- b. involuntary termination (the participant is terminated by the employer prior to completing the selected participation period and is not rehired by another TRSL employer on the following day); and
- c. completion of selected DROP participation period and termination of employment except when the DROP participation period is completed on any day other than the last day of any month. In such cases, the DROP account deposit shall be prorated to coincide with the date of completion of DROP participation and termination of employment. Retirement benefits shall begin the day after completion of the DROP participation period and termination of employment.

* * *

11. When termination of the DROP participation period occurs because of the death of the participant, or if the death of the participant occurs in the absence of an executed Affidavit of Plan Election, the provisions of R.S. 11:783 shall apply.

* * *

AUTHORITY NOTE: Promulgated in accordance with R.S.11:761, 11:783 and 11:786-791.

HISTORICAL NOTE: Promulgated by the Department of the Treasury, Board of Trustees of the Teachers' Retirement System, LR 18:621 (June 1992), amended LR 18:1419 (December 1992), LR 19: (December 1993).

James P. Hadley, Jr.
Director

RULE

Department of Treasury Board of Trustees of the Teachers' Retirement System

Renunciation of Benefits

The Department of the Treasury, Board of Trustees of the Teachers' Retirement System, pursuant to the Notice of Intent published on page 1259 of the September 20, 1993 *Louisiana Register*, and under the authority contained in R.S. 11:826, adopted the following policies concerning the renunciation of benefits:

Any person eligible to receive, or receiving, a benefit from the Teachers' Retirement System of Louisiana (TRSL), may renounce such benefits on the following terms and conditions:

1. The renunciation shall be unconditional and irrevocable. Once a benefit is renounced, TRSL shall have no

further obligation or liability with respect to that benefit, and the person renouncing the benefit shall under no circumstances be eligible to receive that benefit.

2. A base benefit may only be renounced in its entirety. If a base benefit is renounced, there shall be no eligibility for later adjustment of benefits of any kind. An adjustment to a base benefit (cost-of-living adjustment or adjustment for inflation) may only be renounced in its entirety. If an adjustment is renounced, the base benefit need not be renounced.

3. A benefit may be renounced before or after payment begins. If the renunciation is after the start of payments, any payments received prior to the effective date of the renunciation are not affected.

4. If the party making the renunciation is married, the spouse must join in the renunciation.

5. If the person making the renunciation is subject to a court order or community property settlement submitted to and approved by TRSL in accordance with R.S. 11:291, only that portion of the benefit due the person making the renunciation may be renounced, except as provided for in R.S. 11:783(D).

6. If the person making the renunciation is legally separated or divorced, but is not subject to a court order or community property settlement submitted to and approved by TRSL in accordance with R.S. 11:291, the renunciation must be approved by the court having jurisdiction over the separation or divorce.

7. If the person making the renunciation is retired and has named a joint and survivor beneficiary, the renunciation cannot affect the joint and survivor beneficiary or benefit, including adjustments to the joint and survivor benefit.

8. A renunciation must be made on a form provided by TRSL, and must be executed before a notary public and two witnesses, neither of whom may be a spouse or presently named beneficiary. The renunciation is effective and irrevocable when received by TRSL, and may not be retroactive.

9. A person revoking or participating in revocation of a benefit must hold TRSL harmless from such action.

10. A revocation may not be used to terminate active participation in TRSL.

11. Amounts credited to a DROP account cannot be renounced.

12. TRSL makes no representation with respect to the effect of a revocation on a person's eligibility for receipt of any state or federal benefits, or for participation in any private, local, state or federal program. Eligibility for or participation in such programs, or eligibility for or receipt of such benefits, is an issue for which the person making the revocation is solely responsible. Ineligibility for or termination of participation in such programs or benefits shall not affect the irrevocable character of the renunciation.

AUTHORITY NOTE: Promulgated in accordance with R.S. 11:826.

HISTORICAL NOTE: Promulgated by the Department of the Treasury, Board of Trustees of the Teachers' Retirement System, LR 19: (December 1993).

James P. Hadley, Jr.
Director

NOTICES OF INTENT

NOTICE OF INTENT

Department of Economic Development Board of Examiners of Certified Shorthand Reporters

Continuing Education Credits (LAC 46:XXI.603)

In accordance with R.S. 49:950 et seq., the Administrative Procedure Act and R.S. 37:2554, notice is hereby given that the Board of Examiners of Certified Shorthand Reporters is amending Title 46, Part XXI of the Louisiana Administrative Code. This amendment will make the deadline for continuing education the same for all court reporters.

Title 46

PROFESSIONAL AND OCCUPATIONAL STANDARDS

Part XXI. Certified Shorthand Reporters

Chapter 6. Continuing Education

§603. Continuing Education Credits

A. Beginning January 1, 1991, and thereafter, each holder of a certificate issued by the Board of Certified Shorthand Reporters shall be required to obtain at least 12 continuing education credits during a period of two consecutive calendar years.

B. Any holder of a certificate issued by the board is exempt from the requirement of continuing education for the calendar year in which the certification is initially issued. If the holder is certified in an odd numbered year, the certificate holder shall be required to obtain at least six continuing education credits during the calendar year following the year in which the certification was issued. If the holder is certified in an even numbered year, the certificate holder shall be required to obtain at least 12 continuing education credits during the two calendar years following the year in which the certification was issued.

AUTHORITY NOTE: Promulgated in accordance with R.S. 37:2554.

HISTORICAL NOTE: Promulgated by the Department of Economic Development, Board of Examiners of Certified Shorthand Reporters, LR 17:32 (January 1991), amended LR 20:

Interested persons may submit written or oral comments to Gay M. Pilié, Board of Examiners of Certified Shorthand Reporters, 325 Loyola Avenue, Suite 306, New Orleans, LA 70112, (504) 523-4306. Comments will be accepted through the close of business on January 20, 1994.

Peter Gilberti
Secretary

FISCAL AND ECONOMIC IMPACT STATEMENT FOR ADMINISTRATIVE RULES RULE TITLE: Continuing Education

- I. ESTIMATED IMPLEMENTATION COSTS (SAVINGS) TO STATE OR LOCAL GOVERNMENTAL UNITS (Summary)
There will be no anticipated effect on costs or savings to state governmental units.
- II. ESTIMATED EFFECT ON REVENUE COLLECTIONS OF STATE OR LOCAL GOVERNMENTAL UNITS (Summary)
There will be no anticipated effect on revenue to state governmental units.
- III. ESTIMATED COSTS AND/OR ECONOMIC BENEFITS TO DIRECTLY AFFECTED PERSONS OR NON-GOVERNMENTAL GROUPS (Summary)
There will be no anticipated effect on costs to nongovernmental groups.
- IV. ESTIMATED EFFECT ON COMPETITION AND EMPLOYMENT (Summary)
There will be no anticipated effect on competition or employment due to the proposed rule.

Peter Gilberti
Secretary

David W. Hood
Senior Fiscal Analyst

NOTICE OF INTENT

Department of Economic Development Board of Examiners of Certified Shorthand Reporters

Reportorial Services (LAC 46:XXI.Chapter 11)

In accordance with R.S. 37:2551 et seq., and R.S. 49:950 et seq., the Administrative Procedure Act, notice is hereby given that the Louisiana Board of Examiners of Certified Shorthand Reporters proposes to amend Part XXI of the Louisiana Administrative Code. This amendment prohibits certain contracting and creates a policy for submission of transcripts.

Title 46

PROFESSIONAL AND OCCUPATIONAL STANDARDS

Part XXI. Certified Shorthand Reporters

Chapter 11. Reportorial Services

§1101. Prohibited and Permitted Contracts

A. Contracts covering reportorial services having a fixed period of time, minimum or otherwise, between persons holding certificates under Chapter 32, R.S. 37:2551 et seq., or any person for whom such reporters act as agents and any attorney at law or agent thereof or any insurance company or agent thereof or any other person, are prohibited. This prohibition includes, but is not limited to, business entities, their employees, agents, contractors and/or subcontractors, whether either or all is domiciled inside or outside the state of Louisiana, who conduct reportorial services within the state of Louisiana pertaining to any and all matters over which any court of law situated in the state of Louisiana has jurisdiction.

B. The above prohibition does not prevent any person

holding a certificate, upon request of an attorney or an agent of an attorney or an insurance company, from quoting rates for both originals and copies of depositions for a particular deposition to be taken, or for all depositions in a case, provided that the same rate must be charged to all other parties obtaining copies and provided further that the charge for the original will be no less than 60 percent higher than the charge per copy. Only persons holding certificates as defined under Chapter 32, R.S. 37:2551 et seq., or persons holding certificates acting as agents for any entity over whom this board has jurisdiction shall be authorized to enter into the arrangements as hereinbefore set forth in this Paragraph.

C. Any person holding a certificate under Chapter 32, R.S. 37:2551 et seq., shall disclose, on the record in every deposition taken, the complete arrangement, financial and otherwise, made between the reporter or the agency making arrangements for the reporter's services and the attorney or other person making such arrangements with the reporter or agency.

D. Any person holding a certificate under Chapter 32, R.S. 37:2551 et seq., and any reportorial service by which such person is associated shall, when the bill for the deposition or depositions in question is submitted to each of the attorneys or other organizations ordering the deposition and any copies thereof, set forth on the face of the bill any consideration paid, given or agreed to be paid or given by the person or reportorial service in any form.

E. All incentive programs are expressly forbidden in the state of Louisiana by any reporter, reporting agency, their agents, employees, contractors, and/or subcontractors.

AUTHORITY NOTE: Promulgated in accordance with R.S. 37:2551, et seq., more particularly R.S. 37:2553 and 37:2554.

HISTORICAL NOTE: Promulgated by the Department of Economic Development, Board of Examiners of Certified Shorthand Reporters, LR 20:

§1103. Submission of Transcripts

Any person holding a certificate under Chapter 32, R.S. 37:2551 et seq., including their employees, agents, subcontractors and/or contractors, shall not furnish a transcript or any part thereof in any way, shape, or form to any person not a party to the prosecution of the matter or case without the expressed consent, written or verbal, by the party or parties so authorized to grant such consent; and the transcript fee therefor shall not exceed the normal and customary fees charged for such services performed during the usual course of business.

AUTHORITY NOTE: Promulgated in accordance with R.S. 37:2551 et seq., more particularly R.S. 37:2553 and 37:2554.

HISTORICAL NOTE: Promulgated by the Department of Economic Development, Board of Examiners of Certified Shorthand Reporters, LR 20:

§1105. Cause for Suspension, Revocation or Non-issuance of Certificate

Any violation of this rule shall be cause for refusal of the board to issue certification to any applicant. Any willful violation of this rule promulgated by the board shall be grounds for the discipline, censure, suspension or revocation of certification of persons holding certificates within the state of Louisiana.

AUTHORITY NOTE: Promulgated in accordance with R.S.

37:2551 et seq., more particularly R.S. 37:2553 and 37:2554.

HISTORICAL NOTE: Promulgated by the Department of Economic Development, Board of Examiners of Certified Shorthand Reporters, LR 20:

Interested persons may submit written or oral comments to Gay M. Pilié, Board of Examiners of Certified Shorthand Reporters, 325 Loyola Avenue, Suite 306, New Orleans, LA 70112, (504) 523-4306. Comments will be accepted through the close of business on January 21, 1994.

Peter Gilberti
Secretary

FISCAL AND ECONOMIC IMPACT STATEMENT FOR ADMINISTRATIVE RULES RULE TITLE: Reportorial Services

I. ESTIMATED IMPLEMENTATION COSTS (SAVINGS) TO STATE OR LOCAL GOVERNMENTAL UNITS (Summary)

The estimated implementation of costs to the board from its self-generated funds is \$4,000 for FY '93-'94, which will be used for publication and dissemination of the proposed rule.

II. ESTIMATED EFFECT ON REVENUE COLLECTIONS OF STATE OR LOCAL GOVERNMENTAL UNITS (Summary)

There will not be any effect on revenue collections of the board as a result of the proposed rule.

III. ESTIMATED COSTS AND/OR ECONOMIC BENEFITS TO DIRECTLY AFFECTED PERSONS OR NON-GOVERNMENTAL GROUPS (Summary)

The economic benefits to directly affected persons or nongovernmental groups would be an increase in business which may be forfeited by persons or nongovernmental groups who do not comply with the proposed rule. There will be no negative effect as a result of the proposed rule.

IV. ESTIMATED EFFECT ON COMPETITION AND EMPLOYMENT (Summary)

Adoption of the proposed rule does not negatively impact employment in the public and private sectors.

Peter Gilberti
Secretary

David W. Hood
Senior Fiscal Analyst

NOTICE OF INTENT

Department of Economic Development Used Motor Vehicles and Parts Commission

Identification Cards (LAC 46:V.2801)

In accordance with Revised Statutes Title 32, Chapters 4A and 4B, the Department of Economic Development, Used Motor Vehicle and Parts Commission, proposes to adopt the following rule.

Title 46 PROFESSIONAL AND OCCUPATIONAL STANDARDS Part V. Automotive Industry Subpart 2. Used Motor Vehicle and Parts Commission

Chapter 28. Used Motor Vehicle Identification Card
§2801. Identification Cards

A. All licensees of the Used Motor Vehicle and Parts Commission will be issued identification cards.

B. Identification cards will consist of individual's name, driver's license number, Social Security number, dealership name, dealer number, salesman number, photograph and the individual's signature. Each identification card will bear the signature of the executive director of the Used Motor Vehicle and Parts Commission.

C. Each used motor vehicle dealer, automotive dismantler and parts recycler, salesman and buyer must carry on their person and produce on demand the dealer/salesman identification card while conducting the business for which this license has been issued.

AUTHORITY NOTE: Promulgated in accordance with R.S. 32:772 E.

HISTORICAL NOTE: Promulgated by the Department of Economic Development, Used Motor Vehicle and Parts Commission, LR 20:

Interested persons may submit written comments concerning this proposed rule until January 7, 1994 to John Alario, Executive Director, Used Motor Vehicle and Parts Commission, 3132 Valley Creek Drive, Baton Rouge, LA 70808.

John W. Alario
Executive Director

FISCAL AND ECONOMIC IMPACT STATEMENT
FOR ADMINISTRATIVE RULES
RULE TITLE: Identification Card

- I. **ESTIMATED IMPLEMENTATION COSTS (SAVINGS) TO STATE OR LOCAL GOVERNMENTAL UNITS (Summary)**
Estimated implementation costs will be approximately \$4,000 for 1993-94. This will cover the cost of the forms and computer programming. The cost for 1994-95 and 1995-96 will be approximately \$3,000 which will cover the cost of printing forms only. The commission will utilize existing personnel and equipment.
- II. **ESTIMATED EFFECT ON REVENUE COLLECTIONS OF STATE OR LOCAL GOVERNMENTAL UNITS (Summary)**
There is no effect on revenue collections as a result of the proposed rule.
- III. **ESTIMATED COSTS AND/OR ECONOMIC BENEFITS TO DIRECTLY AFFECTED PERSONS OR NON-GOVERNMENTAL GROUPS (Summary)**
The issuance of the identification cards to licensees will be of great benefit since it will prevent unlicensed individuals from buying used vehicles at auto auctions and insurance salvage pools.
- IV. **ESTIMATED EFFECT ON COMPETITION AND EMPLOYMENT (Summary)**
With the issuance of identification cards, competition will be affected as it will require those unlicensed individuals to obtain a used motor vehicle dealer and/or salesman's license and meet all necessary requirements.

John W. Alario
Executive Director

David W. Hood
Senior Fiscal Analyst

NOTICE OF INTENT

Board of Elementary and Secondary Education

Bulletin 746—Standards for Certification
of School Personnel—Special Education

In accordance with R.S. 49:950 et seq., the Administrative Procedure Act, notice is hereby given that the Board of Elementary and Secondary Education approved for advertisement the changes/modifications in certification requirements for special education personnel. These requirements are included in Bulletin 746, Standards for State Certification of School Personnel.

The full text of these revised certification requirements may be obtained from the Office of the State Register, located on the Fifth Floor of the Capitol Annex, 1051 North Third Street, Baton Rouge, LA 70804, telephone (504)342-5015 and from the Bureau of Teacher Certification or the Office of the Board of Elementary and Secondary Education located in the Education Building in Baton Rouge, LA 70804, telephone (504) 342-5841.

Interested persons may submit comments on the proposed rule until 4:30 p.m., February 7, 1994 to: Eileen Bickham, State Board of Elementary and Secondary Education, Box 94064, Capitol Station, Baton Rouge, LA 70804-9064.

Carole Wallin
Executive Director

FISCAL AND ECONOMIC IMPACT STATEMENT
FOR ADMINISTRATIVE RULES
RULE TITLE: Certification Requirements for
Special Education Personnel

- I. **ESTIMATED IMPLEMENTATION COSTS (SAVINGS) TO STATE OR LOCAL GOVERNMENTAL UNITS (Summary)**
The adoption of this policy will cost the department approximately \$200 (printing and postage) to disseminate the changes.
- II. **ESTIMATED EFFECT ON REVENUE COLLECTIONS OF STATE OR LOCAL GOVERNMENTAL UNITS (Summary)**
This policy will have no effect on revenue collections.
- III. **ESTIMATED COSTS AND/OR ECONOMIC BENEFITS TO DIRECTLY AFFECTED PERSONS OR NON-GOVERNMENTAL GROUPS (Summary)**
There will be no additional costs or economic benefits to directly affected persons or non-governmental groups as a result of this action.
- IV. **ESTIMATED EFFECT ON COMPETITION AND EMPLOYMENT (Summary)**
The adoption of this policy may provide additional numbers of certified teachers in one area of special education in which required course work for certification would decrease. Otherwise, no effect on competition and employment is anticipated.

Marlyn Langley
Deputy Superintendent for
Management and Finance

David W. Hood
Senior Fiscal Analyst

NOTICE OF INTENT

Board of Elementary and Secondary Education

Bulletin 746—Standards for Certification of School Personnel—Temporary Employment Permits (LAC 28:I.903)

In accordance with R.S. 49:950 et seq., the Administrative Procedure Act, notice is hereby given that the Board of Elementary and Secondary Education approved for advertisement, the following revised policy on Temporary Employment Permits for inclusion in Bulletin 746, Louisiana Standards for State Certification of School Personnel. The revisions printed below which incorporate the provisions of Act 914 of the 1993 Louisiana Legislature were adopted as an emergency rule, and printed in the November, 1993 issue of the *Louisiana Register*.

Temporary Employment Permits

A temporary employment permit, valid for one school year, will be granted to those candidates who meet the qualifying scores on the revised NTE in three out of four modules and whose aggregate score is equal to or above the total score on all four modules required for standard certification. All other standard certification requirements must be met.

When no area examination is required, a temporary employment permit will be granted to candidates who meet qualifying scores in two out of three modules of the Core Battery and whose aggregate score is equal to or above the total score on all three modules of the Core Battery required for certification. All other standard certification requirements must be met.

To employ an individual on a temporary employment permit, a local superintendent must verify that no regularly certified teacher is available for employment. Names of the individuals employed on a temporary employment permit are to be listed on the addendum to the Annual School Report with verification that no regularly certified teacher is available.

An individual can be reissued a permit three times under the board policy only if evidence is presented to the State Department of Education that the NTE has been retaken within one year from the date the permit was last issued. Beginning with the fifth year, to receive a Temporary Employment Permit, an individual must present the following:

1. evidence that the NTE has been taken within one year from the date the permit was last issued;
2. verification from the employing superintendent that the individual is applying for employment in a specific teaching position for which there is no regularly certified teacher available;
3. a recommendation from the employing superintendent;
4. verification of successful local evaluations for the previous four years.

Temporary employment permits will be issued at the request of individuals who meet all requirements for regular certification with the exception of the NTE scores. All application materials required for issuance of a regular certificate must be submitted to the Bureau of Higher

Education and Teacher Certification with the application for issuance of a temporary employment permit.

Since this policy will be included in Bulletin 746, it will be deleted from the Administrative Code as noted below.

Title 28

EDUCATION

Part I. Board of Elementary and Secondary Education Chapter 9. Bulletins, Regulations, and State Plans §903. Teacher Certification Standards and Regulations

* * *

C. Temporary Employment Permits Repealed

* * *

AUTHORITY NOTE: Promulgated in accordance with R.S. 17:76(E), Act 914 of 1993.

HISTORICAL NOTE: Amended by the Board of Elementary and Secondary Education, LR 20:

Interested persons may submit comments on the proposed rule until 4:30 p.m., February 7, 1994 to: Eileen Bickham, State Board of Elementary and Secondary Education, Box 94064, Capitol Station, Baton Rouge, LA 70804-9064.

Carole Wallin
Executive Director

FISCAL AND ECONOMIC IMPACT STATEMENT FOR ADMINISTRATIVE RULES

RULE TITLE: Bulletin 746—Standards for Certification of School Personnel—Temporary Employment Permits (LAC 28:I.903)

- I. ESTIMATED IMPLEMENTATION COSTS (SAVINGS) TO STATE OR LOCAL GOVERNMENTAL UNITS (Summary)
The adoption of this amendment will cost the Department of Education approximately \$50 (printing and postage) to disseminate the amended policy.
- II. ESTIMATED EFFECT ON REVENUE COLLECTIONS OF STATE OR LOCAL GOVERNMENTAL UNITS (Summary)
This policy amendment will have no effect on revenue collection.
- III. ESTIMATED COSTS AND/OR ECONOMIC BENEFITS TO DIRECTLY AFFECTED PERSONS OR NON-GOVERNMENTAL GROUPS (Summary)
The amendment to this policy will authorize the issuance of an unlimited number of teaching permits to certain individuals who are not yet eligible for a standard teaching certificate. Previous policy allowed the issuance of only five temporary permits.
- IV. ESTIMATED EFFECT ON COMPETITION AND EMPLOYMENT (Summary)
This policy will allow individuals who are eligible for teaching permits to be issued a permit for an unlimited number of years, providing additional individuals who are eligible for employment.

Marlyn Langley
Deputy Superintendent for
Management and Finance

David W. Hood
Senior Fiscal Analyst

NOTICE OF INTENT

Board of Elementary and Secondary Education

Bulletin 746—Standards for Certification of School Personnel—Temporary Teaching Assignments

In accordance with R.S. 49:950 et seq., the Administrative Procedure Act, notice is hereby given that the Board of Elementary and Secondary Education, approved for advertisement, the following revisions to the regulations, policies, and procedures for granting temporary teaching assignments for inclusion in Bulletin 746, Louisiana Standards for State Certification of School Personnel.

Temporary Teaching Assignments

Local school systems and diocesan systems shall have the authority to grant temporary teaching assignments. A temporary teaching assignment, valid for one school session only and the summer immediately following the school year, and authorizing the employment of a specified teacher in a position for which he is not regularly certified, may be issued by the employing superintendent according to the following regulations.

1. For public schools, the local superintendent must sign the following statement on each temporary teaching assignment:

"I hereby certify that there is no regularly certified, competent, and suitable person available for this position and that the applicant named above is the best qualified person available for employment in the position herein above described."

2. A temporary teaching assignment may be made only for persons who have a baccalaureate degree.

3. Teachers in public schools, and special education teachers in nonpublic schools, who do not have a regular Louisiana teaching certificate must have the appropriate scores on the NTE and be eligible for admission to an approved teacher education program.

4. Renewals may be made on a yearly basis. To be eligible for reemployment on a temporary teaching assignment, a minimum of six semester hours of resident or extension credit must be earned. The hours must be applicable toward certification in the area in which the temporary teaching assignment was approved.

5. Temporary teaching assignments shall be made on forms prescribed by the State Department of Education.

6. The local school system and diocesan systems shall be responsible for maintaining files on all temporary teaching assignments.

7. A temporary teaching assignment may be reissued by a local school system or diocesan system to an applicant who has not met the requirement of earning six semester hours of college credit when one or more of the following conditions are met.

A. Medical Excuse. When serious medical problems of the teacher or immediate family in the same household exist, a doctor's statement is required with a letter of assurance from the superintendent and teacher that the hours will be earned.

B. Required Courses not Available. A letter of verification from area universities is required stating that the required courses are not being offered.

C. Change of School, Parish or School System. A justification letter from the superintendent is required. Reissuance is permitted only if the change is not part of a continuous pattern.

D. Change of Certification Areas. A letter of justification from the superintendent is required to explain the new job assignment with assurance that the requirements for the next temporary teaching assignment will be met.

E. Courses not Applicable Toward Certification. A letter of justification from the superintendent is required with assurance that the teacher will become enrolled in the proper program.

These are the only conditions that may be used. Documentation which supports the above condition must be maintained in the teacher's personnel file. (The Bureau of Higher Education and Teacher Certification will use the same criteria for issuing TTA's to teachers in private schools.)

8. The local school systems and diocesan systems shall be accountable for all aspects of this program.

9. The State Department of Education shall monitor the implementation of the regulations for temporary teaching assignments.

NOTE: Private, nondiocesan schools must apply to the State Department of Education, Bureau of Higher Education and Teacher Certification for a Temporary Teaching Certificate. The regulations listed above which apply to nonpublic schools are also applicable for private, nondiocesan schools.

AUTHORITY NOTE: R.S. 17:6.

These revisions were also adopted as an emergency rule and printed in the November, 1993 issue of the *Louisiana Register*.

Interested persons may submit comments on the proposed rule until 4:30 p.m., February 7, 1994 to: Eileen Bickham, State Board of Elementary and Secondary Education, Box 94064, Capitol Station, Baton Rouge, LA 70806-9064.

Carole Wallin
Executive Director

FISCAL AND ECONOMIC IMPACT STATEMENT FOR ADMINISTRATIVE RULES

RULE TITLE: Temporary Teaching Assignments

- I. ESTIMATED IMPLEMENTATION COSTS (SAVINGS) TO STATE OR LOCAL GOVERNMENTAL UNITS (Summary)
The adoption of this proposed rule will cost the Department of Education approximately \$50 (printing and postage) to disseminate the amended policy.
- II. ESTIMATED EFFECT ON REVENUE COLLECTIONS OF STATE OR LOCAL GOVERNMENTAL UNITS (Summary)
The proposed rule will have no effect on revenue collection.
- III. ESTIMATED COSTS AND/OR ECONOMIC BENEFITS TO DIRECTLY AFFECTED PERSONS OR NON-GOVERNMENTAL GROUPS (Summary)

There will be no additional costs or economic benefits to directly affect persons or non-governmental groups as a result of this action.

IV. ESTIMATED EFFECT ON COMPETITION AND EMPLOYMENT (Summary)

This action will have no effect on competition and employment.

Marlyn Langley
Deputy Superintendent for
Management and Finance

David W. Hood
Senior Fiscal Analyst

NOTICE OF INTENT

Board of Elementary and Secondary Education

Bulletin 1868—BESE Personnel Manual

In accordance with R.S. 49:950 et seq., the Administrative Procedure Act, notice is hereby given that the Board of Elementary and Secondary Education approved for advertisement, the following amendment to Bulletin 1868, BESE Personnel Manual.

Chapter C: Employee Personnel Activities

131: Reduction in Force

* * *

B. Special School District Number 1

* * *

3. Teachers

h. Other Policy Provisions Governing Reduction in Force for Teachers

* * *

(3) Seniority begins to accrue with the effective date of employment as approved by the board to regular full-time employment in a certified position.

NOTE: Regular employment means continuous contracted service in a vacant position (i.e., not as a substitute for some other teacher). A teacher who has a break in contracted service (other than as a result of layoff under this policy; a situation which is governed by 131 B.3.h.(4) does not receive credit toward seniority for the service prior to the break).

AUTHORITY NOTE: R. S. 17.6.

Interested persons may submit comments on the proposed rule until 4:30 p.m., February 7, 1994 to: Eileen Bickham, State Board of Elementary and Secondary Education, Box 94064, Capitol Station, Baton Rouge, LA 70804-9064.

Carole Wallin
Executive Director

FISCAL AND ECONOMIC IMPACT STATEMENT FOR ADMINISTRATIVE RULES

**RULE TITLE: Bulletin 1868
BESE Personnel Manual**

I. ESTIMATED IMPLEMENTATION COSTS (SAVINGS) TO STATE OR LOCAL GOVERNMENTAL UNITS (Summary)

There is no estimated implementation cost or savings for this action. The note of clarification added to Chapter C, §131 B of Bulletin 1868 will be incorporated into Bulletin 1868. There is no additional cost for printing or dissemination of this note of clarification since the printing and dissemination costs are covered in the original fiscal and impact statement for the revised Bulletin 1868.

II. ESTIMATED EFFECT ON REVENUE COLLECTIONS OF STATE OR LOCAL GOVERNMENTAL UNITS (Summary)

There will be no estimated effect on revenue collections of state or local governmental units.

III. ESTIMATED COSTS AND/OR ECONOMIC BENEFITS TO DIRECTLY AFFECTED PERSONS OR NON-GOVERNMENTAL GROUPS (Summary)

There will be no effect on competition and employment.

IV. ESTIMATED EFFECT ON COMPETITION AND EMPLOYMENT (Summary)

None. This note clarifies the definition of "regular employment" which is used to determine the seniority of certified employees.

Marlyn Langley
Deputy Superintendent
for Management and Finance

David W. Hood
Senior Fiscal Analyst

NOTICE OF INTENT

Board of Elementary and Secondary Education

Bulletin 1903 - Dyslexic Student Education Guidelines

In accordance with R.S. 49:950 et seq., the Administrative Procedure Act, notice is hereby given that the Board of Elementary and Secondary Education approved for advertisement, a revision to Bulletin 1903, Guidelines for Implementation of the Louisiana Law for the Education of Dyslexic Students to add "No child shall be screened if his parent or guardian (tutor) objects to such screening", under Step One of the guidelines as noted below:

Step One. Date Gathering, Screening, and Review

I. Request for Assistance by the School Building Level Committee

A. A request may be made to the school building level committee for review of a student's educational progress if school personnel (principal, guidance counselor, teacher, school nurse) a parent/guardian, community agency personnel, or a student has reason to believe that the student is not making expected progress because of a suspected language processing disorder. No child shall be screened if his parent or guardian (tutor) objects to such screening. This request begins the 60 day timeline. The committee membership may be modified in order that a group of knowledgeable persons may address an individual student's needs.

This amendment is based on language which appears in R.S. 17:392.1(B) and was adopted as an emergency rule and printed in the November, 1993 issue of the *Louisiana Register*.

Interested persons may submit comments on the proposed

rule until 4:30 p.m., February 7, 1994 to: Eileen Bickham, State Board of Elementary and Secondary Education, Box 94064, Capitol Station, Baton Rouge, LA 70804-9064.

AUTHORITY NOTE: R. S. 17:7(11).

Carole Wallin
Executive Director

**FISCAL AND ECONOMIC IMPACT STATEMENT
FOR ADMINISTRATIVE RULES**

**RULE TITLE: Bulletin 1903 - Implementation of
the Dyslexia Law**

**I. ESTIMATED IMPLEMENTATION COSTS (SAVINGS) TO
STATE OR LOCAL GOVERNMENTAL UNITS (Summary)**

It will cost the state approximately \$100 to print and distribute copies of this revised page of the bulletin. One copy will be sent to each dyslexia coordinator in the LEA who will copy and disseminate it to all schools. Copies will be made available to nonpublic schools upon request.

**II. ESTIMATED EFFECT ON REVENUE COLLECTIONS OF
STATE OR LOCAL GOVERNMENTAL UNITS (Summary)**

There would be no effect on revenue collection of state or local governmental units.

**III. ESTIMATED COSTS AND/OR ECONOMIC BENEFITS TO
DIRECTLY AFFECTED PERSONS OR NON-
GOVERNMENTAL GROUPS (Summary)**

There are no estimated costs or economic benefits to directly affected persons or groups.

**IV. ESTIMATED EFFECT ON COMPETITION AND
EMPLOYMENT (Summary)**

There would be no effect on competition and employment.

Marlyn Langley
Deputy Superintendent for
Management and Finance

David W. Hood
Senior Fiscal Analyst

NOTICE OF INTENT

Board of Elementary and Secondary Education

**Hiring Noncertified School Personnel
(LAC 28:I.903)**

In accordance with R.S. 49:950 et seq., the Administrative Procedure Act, notice is hereby given that the Board of Elementary and Secondary Education approved for advertisement, the following revised interim policy for hiring full-time/part-time noncertified school personnel. This is a revision to the Administrative Code, Title 28 as noted below.

Title 28

EDUCATION

**Part I. Board of Elementary and Secondary Education
Chapter 9. Bulletins, Regulations, and State Plans
§903. Teacher Certification Standards and Regulations**

* * *

I. Noncertified Personnel

1. Full-time/part-time noncertified school personnel,

excluding speech, language, and hearing specialists, may be employed by parishes having difficulty in employing certified persons in certain positions, provided that the following documentation is submitted to the Department of Education:

a. a signed affidavit by the local superintendent that the position could not be filled by a certified teacher;

b. submission of names, educational background, subject matter and grade level being taught as an addendum to the Annual School Report; and

c. documentation kept on file in the LEA's superintendent's Personnel Office shall include:

i. copies of transcripts showing the degree earned;

ii. documentation that efforts for recruitment of certified teachers have been made (e.g. newspaper advertisements, letters, contacts with colleges, and so forth);

iii. documentation that the teacher is eligible for admission to a teacher education program.

d. In addition:

i. it is required that these teachers take the NTE at the earliest date that it is offered in their geographical area; and

ii. these individuals must have a minimum of a baccalaureate degree from a regionally accredited institution and be eligible for admission to a teacher education program;

iii. to be re-employed under this policy, an individual must have earned at least six semester hours toward completion of a teacher education program or six semester hours appropriate to the area of the NTE (general knowledge, professional knowledge, communication skills, specialty area) in which the score was not achieved;

iv. effective with the 1992-93 school year, the total number of years a person may be employed according to the provisions of this policy, inclusive of experience prior to 1992-93, is five years;

v. these individuals shall be employed at a salary that is based on the effective state salary schedule for a beginning teacher with a baccalaureate degree and a certificate with zero years of experience. Local salary supplements are optional;

vi. copies of transcripts showing the six semester hours and a copy of the NTE score card showing the NTE has been taken since the last employment under this policy shall be kept on file in the LEA's superintendent's Personnel Office;

vii. to be eligible for re-employment under this policy, a teacher who has not met the requirement of earning six semester hours of college credit or who has not taken the NTE must meet one or more of the following conditions:

(a). Medical Excuse. When serious medical problems of the teacher or immediate family in the same household exist, a doctor's statement is required with a letter of assurance from the superintendent and teacher that the hours will be earned.

(b). Required Courses not Available. A letter of verification from area universities is required stating that the required courses are not being offered.

(c). Change of School, Parish or School System. A justification letter from the superintendent is required. Reissuance is permitted only if the change is not part of a continuous pattern.

(d). Change of Certification Areas. A letter of

justification from the superintendent is required to explain the new job assignment with assurance that the requirements for continued employment under this policy will be met.

(e). Courses not Applicable Toward Certification.

A letter of justification from the superintendent is required with assurance that the teacher will become enrolled in the proper program.

(These are the only conditions that may be used.

Documentation which supports the above condition must be maintained in the teacher's personnel file.)

AUTHORITY NOTE: Promulgated in accordance with R.S. 17:7.

HISTORICAL NOTE: Amended by the Board of Elementary and Secondary Education, LR 20:

This interim emergency policy will remain in effect until July 1, 1995.

This policy was amended as an emergency rule and printed in the November, 1993 issue of the *Louisiana Register*.

Interested persons may submit comments on the proposed rule until 4:30 p.m., February 7, 1994 to: Eileen Bickham, Board of Elementary and Secondary Education, Box 94064, Capitol Station, Baton Rouge, LA 70804-9064.

Carole Wallin
Executive Director

FISCAL AND ECONOMIC IMPACT STATEMENT FOR ADMINISTRATIVE RULES

RULE TITLE: Circular 665 - Hiring Noncertified School Personnel (Interim Policy)

I. ESTIMATED IMPLEMENTATION COSTS (SAVINGS) TO STATE OR LOCAL GOVERNMENTAL UNITS (Summary)

The adoption of this policy will cost the Department of Education approximately \$50 (printing and postage) to disseminate the policy.

II. ESTIMATED EFFECT ON REVENUE COLLECTIONS OF STATE OR LOCAL GOVERNMENTAL UNITS (Summary)

This policy will have no effect on revenue collections.

III. ESTIMATED COSTS AND/OR ECONOMIC BENEFITS TO DIRECTLY AFFECTED PERSONS OR NON- GOVERNMENTAL GROUPS (Summary)

The extension of this policy will allow noncertified school personnel to be employed by local school systems when there is no certified teacher available.

IV. ESTIMATED EFFECT ON COMPETITION AND EMPLOYMENT (Summary)

The extension of this policy allows school systems to fill vacancies which exist due to the unavailability of certified teachers.

Marlyn Langley
Deputy Superintendent for
Management and Finance

David W. Hood
Senior Fiscal Analyst

NOTICE OF INTENT

Student Financial Assistance Commission Office of Student Financial Assistance

Electronic Funds Transfer (EFT) (LAC 28:V)

The Louisiana Student Financial Assistance Commission announces its intention to amend the Loan Program Policy and Procedure Manual to provide policies and procedures for electronic funds transfer (EFT). Sections 6.1.15 and 6.2.17 will be added to the manual as follows:

6.1.15 Electronic Funds Transfer (EFT) Policy

A. Electronic Funds Transfer Permitted

Federal regulations (CFR 682.207) permit lenders to disburse FFELP funds to postsecondary institutions via EFT if so authorized by the guarantor. Provided that both the lender and the school participating in the electronic transfer of LASFAC guaranteed funds utilize the LASFAC policies and procedures, they will be considered authorized by LASFAC. EFT replaces paper transactions (i.e., checks, drafts) with the electronic transfer of funds from the originating lender to the school. EFT allows those lending and postsecondary institutions participating under the LASFAC guarantee a state-of-the-art method by which funds and documentation may be transmitted.

B. School Participation Criteria

1. School must have participated in the Part B student loan programs for at least five years immediately preceding the application for electronic funds transfer/electronic data interchange (EFT/EDI).

2. No school facing limitation, suspension or termination proceedings or legal action by the U.S. Department of Education, a guaranty agency, the Office of the Inspector General, the Office of the Attorney General or any other state or federal agency may participate in EFT/EDI.

3. Any school with adverse program review or audit findings related to the student loan program or accounting procedures of Level 3 or higher will not be permitted to participate in EFT/EDI. Level 3 findings reflect a consistent pattern of institutional practices which clearly indicate impaired administrative capability. They are very serious deficiencies which warrant administrative action, such as a fine, limitation or termination. Examples include untimely refunds or no refunds, failure to adhere to "ability to benefit" procedures, loans certified for students enrolled in ineligible programs or branch campuses, and inadequate or nonexistent fiscal records.

4. Minimum program length must be 600 clock hours.

5. Loan cancellations may not exceed 25 percent of loans guaranteed per enrollment period.

6. Student borrower withdrawal rate from the participating school may not exceed 25 percent per enrollment period.

7. Refunds, repayments and reports from the school must historically have been submitted/paid in a timely manner.

C. Lender Participation Criteria

1. Lenders must have participated in the FFELP for at least three years and have exhibited administrative capability.

2. Lenders may not require a school to share the float on funds in the restricted EFT account or accept payments from the school in order to insure the lender's continued willingness to make loans.

3. Any lender with adverse program review or audit findings related to the student loan program or accounting procedures of Level 3 will not be permitted to participate in EFT/EDI. Level 3 findings are very serious findings in which the lender is suspected of fraud, or LASFAC has information which would support termination action against the lender. Lenders may also be barred from EFT/EDI if they have audit or program review findings of Level 2, under certain circumstances such as those which reflect gross neglect and/or very high monetary liabilities.

D. Administrative Requirements. The school and lender participating in EFT procedures must adequately address the following.

1. Confirmation Procedures. Such procedures must assure that funds transferred have been received by the school and properly credited to the borrower's account.

2. Reconciliation Procedures

a. Adequate reconciliation procedures should be in place at the school to ensure that funds not credited to the student's account are refunded to the lender in a timely manner and that the funds sent from the school to the lender are received by the lender.

b. These procedures must provide for a method to notify the lender of cancellation of a loan and return of such funds to the lender.

c. These procedures may be EDI based or paper based.

3. Audit Trail. Institutions must have the technical and electronic capability to provide a clear audit trail of all transactions relating to EFT/EDI.

4. Records Retention

a. School records relating to EFT/EDI must be maintained until five years following pay-off of the loan.

b. The school may contract with a lender or agency to maintain such records on the school's behalf.

c. In addition to conventional record retention requirements for all Title IV student loan programs, schools and lenders must be prepared to retain paper or electronic records for all entries and transactions relating to each EFT/EDI transaction.

* * *

6.2.17 Electronic Funds Transfer Procedures

A. Participation

1. Lenders and schools who wish to participate in LASFAC's electronic funds transfer (EFT) process must each sign the "Agreement among Lender, School and LASFAC for the Participation in Electronic Funds Transfer (EFT)."

EFT is an optional method for transferring Federal Family Education Loan Program (FFELP) funds to schools to be delivered to student borrowers. The EFT Agreement and this document describe the procedures and regulations LASFAC requires schools and lenders to follow to participate in the EFT process.

2. For a school to initiate or continue participation in LASFAC's EFT agreement, the school must have participated in the FFELP program for at least five years, and exhibit

administrative capability, which includes but is not limited to fiscal responsibility, record keeping and accounting capability, and the conducting of entrance and exit counseling.

3. Lenders and schools who participate in LASFAC's EFT process must comply with all applicable statutes, regulations and LASFAC rules. Specifically, federal regulations that apply include, but are not limited to, 34 Sec. 682.207, 682.610, 682.604 and 682.414 and LASFAC's Policy and Procedure Manual.

4. For students who do not wish to participate in the EFT process, a method to obtain FFELP funds via standard check disbursement must be available.

B. Record Layout. LASFAC provides a suggested "Disbursement Data Record Layout for Magnetic Tape or Telecommunications Transfer" that a lender may use to transfer the student record data to the school.

C. Disbursement and School Receipt of Funds

1. Proceeds for all disbursements may not be transferred by the lender to the school earlier than the disbursement date established by the school in compliance with federal requirements. The lender may not transfer funds to the school's restricted account earlier than 30 days prior to the beginning of the loan period.

2. LASFAC recommends that the school establish a separate and restricted bank account for the receipt of all FFELP loan funds. If the school does not establish a separate and restricted bank account, the school must deposit the funds into its Federal Financial Aid bank account and must maintain a separate general ledger control account, which is used for FFELP purposes only.

D. Borrower Notification

1. The lender must notify the student when funds are transferred to the school on his behalf. The notification must contain specific information about the loan and remind the student that the funds must be repaid.

2. LASFAC requires that each school participating in EFT notify students of the following information.

a. The lender selected by the student will transmit student loan funds to the school through the EFT process.

b. The student has the option to revoke his EFT authority and receive his funds by check.

c. The student will be required to sign a "Borrower Authorization Statement" no earlier than 30 days prior to the beginning date of the loan period.

d. A statement which reflects that the student loan proceeds (which must be repaid) have been credited to the student's account must be produced by the school and given to the student. The student's fee bill or receipt may be imprinted with this information.

e. The method by which the student can receive any excess funds; however, in no case will those funds be released to the student more than 10 days prior to the beginning date of the applicable disbursement period.

E. Borrower Authorization Statement

1. The common application/promissory note includes an Electronic Fund Transfer authorization statement (Item 16 of the application) for electronic transfer of funds. ED has determined that this certification provision will meet the requirements of 34 CFR §682.207(b)(1)(ii)(B) if the school

provides a notice to the borrower either 30 days before the date the school credits the student's account with the loan proceeds or not later than 30 days after that date notifying the borrower that the funds have been credited to the borrower's account at the school. If a student uses the common application, does not use the checkoff to indicate he wants EFT disbursement, and later decides he wants EFT, the lender and school must utilize the Borrower Authorization Statement within 30 days of the transfer. ED is not prescribing the form of the notice. However, a billing statement, award letter, receipt form or other appropriate notification procedure by the institution could meet this requirement. For any application in use other than the common application, however, a Borrower Authorization Statement is required and the procedures herein must be followed.

2. LASFAC will provide a computer generated "Borrower Authorization Statement" (BAS) form for use by borrower's attending schools at which EFT is available, for the school or the lender to obtain the student's authorization to transfer funds into his student account. A different Borrower Authorization Statement may be used; however, in this case, LASFAC must review and approve the language to be used on the statement.

a. The BAS may not be signed by the student more than 30 days prior to the beginning date of the loan period. LASFAC requires that the student be provided a copy of the BAS.

b. The borrower may not provide power of attorney to any person or institution for the purpose of executing the Borrower Authorization Statement except that, at the request of the borrower, a student who is studying outside the U.S. in a program of study approved for credit by the home institution at which the student is enrolled, the Borrower's Authorization Statement may be executed pursuant to an authorized power-of-attorney.

c. The BAS will be handled in one of the following ways.

i. If the school obtains the BAS, whether due to older form of application or to denial of EFT on common application and subsequent change of mind, the following steps should be followed.

(a). The school may send or give the BAS to the student who must sign and date it no earlier than 30 days prior to the loan period begin date.

(b). The school obtains the student's signature on a BAS.

(c). The original of the BAS must be sent to the lender on a schedule determined between the lender and the school.

(d). The school is not required to retain an exact copy of the BAS; the school should, however, archive receipt of the BAS through the school's usual record retention methods.

(e). The lender transmits funds to the school according to Subsection F of these procedures.

(f). The school may not apply funds to the student's account or deliver funds to the student until the signed BAS has been received, and then only in accordance with Section 682.604d of the regulations.

ii. If the lender obtains the BAS, do the following:

(a). The lender may send or give the BAS to the student who must sign and date it no earlier than 30 days prior to the loan period begin date.

(b). The lender obtains the student's signature on the BAS.

(c). The lender retains the original copy of the BAS, acting as an agent for the school.

(d). The lender does not transmit funds to the school until the signed BAS is received.

F. Release or Return of Funds. The school may credit the student's account and/or deliver the proceeds to the student in accordance with federal regulations and LASFAC policy governing the negotiations of student loan funds, provided the student is registered and meets all other conditions of eligibility. In no case may EFT funds be applied to a student's account earlier than 21 days prior to the loan period begin date. If the student is a first time, first year undergraduate borrower, funds may not be applied to the student's account earlier than 30 days after the first day of the student's program of study.

1. If excess funds exist, they may not be disbursed to the student earlier than 10 days prior to the first day of classes of the period of enrollment for which the loan is intended. If the student requests the school to retain the excess funds to assist the student in managing his funds, the school must obtain that authorization from the student through a separate form.

2. For enrolled students, the school has 45 days from the receipt date of the student's funds to credit the funds to the student's account or return the funds to the lender unless the provisions of 6.2.12 of this manual apply.

3. For students who do not meet enrollment requirements at the time of receipt of funds, the school shall return the funds to the lender within 30 days after the date on which the school determines that the student did not register or has withdrawn.

4. For students who cease attendance or drop to less than half-time status after receipt of the funds, the school must return any refund to the lender within 30 days after the date on which the school determines that the student no longer meets eligibility requirements, but in no case should it be returned over 60 days after the student actually leaves school.

5. In no case may funds ever be delivered to the student if the time from when the funds were transferred to the school to when funds are delivered exceeds 120 days.

G. Adequate reconciliation procedures must be in place at the school to ensure that funds not credited to a student's account are refunded to the lender in a timely manner and that funds released to the student can be traced through audit procedures. Such reconciliation procedures must also provide for a method to notify the lender of cancellation of a loan and return of such funds to the lender.

H. Record Retention. LASFAC recommends that the school inform the lender (or LASFAC) of the disposition of EFT'd funds deposited in each student's account. Confirmation and reconciliation procedures and proper audit trails to track all transactions pertaining to the loan must exist. LASFAC suggests that the following information be provided:

1. school code;
2. borrower name (last, first, MI);
3. borrower SSN;
4. LASFAC loan number;
5. lender code;
6. status code:
 - a. student is less than half-time;
 - b. student withdrew/not enrolled/not eligible;
 - c. student graduated;
 - d. student overawarded;
 - e. student request;
 - f. 45 day limit;
7. date of status code action, e.g., withdrawal date;
8. program (Stafford, SLS);
9. amount applied to student's account;
10. amount returning to lender;
11. amount released to student (total of 9, 10 and 11 must equal the full disbursement.)

If the school does not provide all the information listed in item number H to the lender or LASFAC, the school is responsible for retaining this information through their normal archive methods for five years beyond when the loan is paid in full or paid by claim. Such information must be accessible by LASFAC as necessary to insure compliance with the loan program regulations or to prove receipt of the funds by the borrower. If the school does not wish to retain the above information, the information may be sent to LASFAC, either via paper or electronic medium, such as tele-transmission, tape or diskette.

I. These procedures are current as of December, 1993. Should statute or rules and regulations change, LASFAC will make every effort to promptly notify schools and lenders of the changes.

Interested persons may submit written comments on the regulations until 4:30 p.m., February 20, 1994 addressed to: Jack L. Guinn, Executive Director, Office of Student Financial Assistance, Box 91202, Baton Rouge, LA 70821-9202.

Jack L. Guinn,
Executive Director

**FISCAL AND ECONOMIC IMPACT STATEMENT
FOR ADMINISTRATIVE RULES
RULE TITLE: Electronic Funds Transfer**

- I. ESTIMATED IMPLEMENTATION COSTS (SAVINGS) TO STATE OR LOCAL GOVERNMENTAL UNITS (Summary)
No implementation costs are anticipated to implement the proposed rule.
- II. ESTIMATED EFFECT ON REVENUE COLLECTIONS OF STATE OR LOCAL GOVERNMENTAL UNITS (Summary)
No impact on revenue collections are anticipated from the implementation of the proposed rule.
- III. ESTIMATED COSTS AND/OR ECONOMIC BENEFITS TO DIRECTLY AFFECTED PERSONS OR NON-GOVERNMENTAL GROUPS (Summary)
Guaranteed student loan borrowers will enjoy the convenience

of electronic funds transfer rather than paper check handling after the implementation of the proposed rule.

IV. ESTIMATED EFFECT ON COMPETITION AND EMPLOYMENT (Summary)

The implementation of the proposed rule will make this agency more competitive with private sector guarantors who have made electronic transfer of funds available already.

Jack L. Guinn
Executive Director

David W. Hood
Senior Fiscal Analyst

NOTICE OF INTENT

**Department of Environmental Quality
Office of Air Quality and Radiation Protection
Air Quality Division**

Benzene Waste Operations (LAC 33:III.5139) (AQ73)

Under the authority of the Louisiana Environmental Quality Act, particularly R.S. 30:2051 et seq., and in accordance with the provisions of the Administrative Procedure Act, R.S. 49:950, et seq., the secretary gives notice that rulemaking procedures have been initiated to amend the Air Quality Division Regulations, LAC 33:III.5139, (AQ73).

The regulations apply to owners and operators of chemical manufacturing plants, coke by-product recovery plants, petroleum refineries and hazardous waste treatment, storage, and disposal facilities which have specified wastewater containing benzene. If the total annual benzene quantity is greater than 10 Mg/year, controls are required; and if the benzene total is between 1 and 10 Mg/year, recordkeeping and reporting is required. The regulations also contain exemptions for specified waste streams and a waiver provision.

The federal government has promulgated 40 CFR 61, Subpart FF, which is virtually identical in content to the proposed rule, LAC 33:III.5139. Because of waiver delegation for the NESHAPs program (which the DEQ calls LESHAPs) and grant commitments, the Air Quality Division is required to promulgate the rule to maintain the grants and waiver delegation for NESHAPs.

These proposed regulations are to become effective upon publication in the *Louisiana Register*.

A public hearing will be held on January 24, 1994, at 1:30 p.m. in the Maynard Ketcham Building, Room 326, 7290 Bluebonnet Boulevard, Baton Rouge, LA. Interested persons are invited to attend and submit oral comments on the proposed amendments. Should individuals with a disability need an accommodation in order to participate please contact David Hughes at the address given below or at (504)765-0399.

All interested persons are invited to submit written comments on the proposed regulations. Such comments should be submitted no later than Monday, January 31, 1994, at 4:30 p.m., to David Hughes, Enforcement and Regulatory Compliance Division, Box 82282, Baton Rouge, LA, 70884-2282 or to 7290 Bluebonnet Boulevard, Fourth Floor, Baton Rouge, LA, 70810 or to FAX (504)765-0486. Commentors

should reference this proposed regulation by Log AQ73. Check or money order is required in advance for each copy of AQ73.

This proposed regulation is available for inspection at the Office of the State Register, 1051 North Third Street, Baton Rouge, LA, telephone (504)342-5015 and at following DEQ office locations from 8 a.m. until 4:30 p.m.: 7290 Bluebonnet Boulevard, Fourth Floor, Baton Rouge, LA 70810; 804 31st Street, Monroe, LA 71203; State Office Building, 1525 Fairfield Avenue, Shreveport, LA 71101; 3519 Patrick Street, Lake Charles, LA 70605; 3945 North I-10 Service Road West, Metairie, LA 70002; 100 Asma Boulevard, Suite 151, Lafayette, LA 70508.

James B. Thompson, III
Assistant Secretary

FISCAL AND ECONOMIC IMPACT STATEMENT FOR ADMINISTRATIVE RULES

RULE TITLE: Benzene Waste Operations
(LAC 33:III.5139)(AQ 73)

I. ESTIMATED IMPLEMENTATION COSTS (SAVINGS) TO STATE OR LOCAL GOVERNMENTAL UNITS (Summary)

There are no expected additional costs or savings to state and local governmental units because of implementation of this rule. This regulation is equivalent to an existing U.S. Environmental Protection Agency regulation. Any requirements of the existing federal and this proposed state regulation are already being managed by the Air Quality Division.

II. ESTIMATED EFFECT ON REVENUE COLLECTIONS OF STATE OR LOCAL GOVERNMENTAL UNITS (Summary)

There are no expected effects on revenue collections of state or local governmental units.

III. ESTIMATED COSTS AND/OR ECONOMIC BENEFITS TO DIRECTLY AFFECTED PERSONS OR NON-GOVERNMENTAL GROUPS (Summary)

There are no expected change in costs and no economic benefit to directly affected persons or non-governmental groups. Approximately 50 industrial facilities are already impacted by the equivalent U.S. Environmental Protection Agency regulations. This proposed state regulation doesn't require any additional costs to the affected facilities.

IV. ESTIMATED EFFECT ON COMPETITION AND EMPLOYMENT (Summary)

Since this proposed regulation is equivalent to an existing federal regulation it is estimated to have no effect on competition and employment.

Gus Von Bodungen
Assistant Secretary

David W. Hood
Senior Fiscal Analyst

NOTICE OF INTENT

Department of Environmental Quality Office of Air Quality and Radiation Protection Air Quality Division

Chemical Accident Prevention and Fees
(LAC 33:III.Chapters 2 and 59) (AQ31)

Under the authority of the Louisiana Environmental Quality Act, particularly R.S. 30:2051 et seq., and in accordance with the provisions of the Administrative Procedure Act, R.S. 49:950, et seq., the secretary gives notice that rulemaking procedures have been initiated to amend the Air Quality Division Regulations, LAC 33:III.Chapters 2 and 59, (AQ31).

The proposed rule defines for a major stationary source ("A" sources and "synthetic minor" sources in the Compliance Data System (CDS) maintained by the Air Quality Division of DEQ) the "threshold quantity" of a chemical that must be present at a facility for that facility to be regulated. The proposed rule then defines what these regulated facilities must do to minimize the risks associated with that facility. Edits for program specific fees are also included.

The rule is roughly based upon a proposed federal rule. Sections of the proposed federal rule which may significantly change from the proposed rule to the final rule were "Reserved" until the federal rule is finalized. At that time the "Reserved" sections will be clarified and finalized.

These proposed regulations are to become effective upon publication in the *Louisiana Register*.

A public hearing will be held on January 24, 1994, at 1:30 p.m. in the Maynard Ketcham Building, Room 326, 7290 Bluebonnet Boulevard, Baton Rouge, LA. Interested persons are invited to attend and submit oral comments on the proposed amendments. Should individuals with a disability need an accommodation in order to participate please contact David Hughes at the address given below or at (504)765-0399.

All interested persons are invited to submit written comments on the proposed regulations. Such comments should be submitted no later than Tuesday, January 31, 1994, at 4:30 p.m., to David Hughes, Enforcement and Regulatory Compliance Division, Box 82282, Baton Rouge, LA, 70884-2282 or to 7290 Bluebonnet Boulevard, Fourth Floor, Baton Rouge, LA, 70810 or to FAX (504)765-0486. Commentors should reference this proposed regulation by the Log AQ31. Check or money order is required in advance for each copy of AQ31.

This proposed regulation is available for inspection at the following DEQ office locations from 8 a.m. until 4:30 p.m.: 7290 Bluebonnet Boulevard, Fourth Floor, Baton Rouge, LA 70810; 804 31st Street, Monroe, LA 71203; State Office Building, 1525 Fairfield Avenue, Shreveport, LA 71101; 3519 Patrick Street, Lake Charles, LA 70605; 3945 North I-10 Service Road West, Metairie, LA 70002; 100 Asma Boulevard, Suite 151, Lafayette, LA 70508; and also at the Office of the State Register, 1051 North Third, Room 512, Baton Rouge, LA 70802.

James B. Thompson, III
Assistant Secretary

**FISCAL AND ECONOMIC IMPACT STATEMENT
FOR ADMINISTRATIVE RULES
RULE TITLE: Chemical Accident Prevention and Fees (LAC
33:III.Chapters 2 and 59) (AQ31)**

**NOTICE OF INTENT
Department of Environmental Quality
Office of Air Quality and Radiation Protection
Air Quality Division**

**Emission Reduction Credits Banking
(LAC 33:III.Chapter 6) (AQ85)**

Under the authority of the Louisiana Environmental Quality Act, particularly R.S. 30:2051 et seq., and in accordance with the provisions of the Administrative Procedure Act, R.S. 49:950 et seq., the secretary gives notice that rulemaking procedures have been initiated to adopt LAC 33:III.Chapter 6, (AQ85).

The proposed rule is new and generates emission reductions, through emissions banking, which are creditable towards meeting the 15 percent VOC Reduction Reasonable Further Progress Plan mandated by Section 182(b)(1) of the 1990 Clean Air Act Amendments (CAAA). Emissions banking allows the storage of emission reduction credits for future use or to meet the requirements of the 15 percent VOC Reduction Reasonable Further Progress Plan.

Section 182(b)(1) of the CAAA requires all ozone nonattainment areas classified as moderate and above to submit a Reasonable Further Progress Plan by November 15, 1993, which describes how the area will achieve an actual VOC emission reduction of at least 15 percent during the first six years after enactment of the CAAA. The 1996 target level of emissions is the maximum amount of ozone season VOC emissions that can be emitted by an ozone nonattainment area in 1996 for that nonattainment area to be in compliance with the 15 percent Reasonable Further Progress Plan requirements. The banking rule is part of the contingency measures for the 15 percent VOC Reduction RFP.

These proposed regulations are to become effective upon publication in the *Louisiana Register*.

A public hearing will be held on January 24, 1994, at 1:30 p.m. in the Maynard Ketcham Building, (Room 326), 7290 Bluebonnet Boulevard, Baton Rouge, LA. Interested persons are invited to attend and submit oral comments on the proposed amendments. Should individuals with a disability need an accommodation in order to participate please contact David Hughes at the address given below or at (504)765-0399.

All interested persons are invited to submit written comments on the proposed regulations. Such comments should be submitted no later than Tuesday, January 31, 1994, at 4:30 p.m., to David Hughes, Enforcement and Regulatory Compliance Division, Box 82282, Baton Rouge, LA, 70884-2282 or to 7290 Bluebonnet Boulevard, Fourth Floor, Baton Rouge, LA, 70810 or to FAX (504)765-0486. Commentors should reference this proposed regulation by the Log AQ85. Check or money order is required in advance for each copy of AQ85.

This proposed regulation is available for inspection at the following DEQ office locations from 8 a.m. until 4:30 p.m.: 7290 Bluebonnet Boulevard, Fourth Floor, Baton Rouge, LA 70810; 804 31st Street, Monroe, LA 71203; State Office Building, 1525 Fairfield Avenue, Shreveport, LA 71101;

I. ESTIMATED IMPLEMENTATION COSTS (SAVINGS) TO STATE OR LOCAL GOVERNMENTAL UNITS (Summary)

The program is estimated to cost the state \$148,200 in the first year, \$138,200 in the second year, and at least \$146,350 in the third year.

The impact is directed towards major stationary sources classified as "A" sources and "synthetic minor" sources in the Compliance Data System (CDS) maintained by the Air Quality Division of DEQ. This virtually excludes local governmental units so there is no anticipated impact to local governmental units.

II. ESTIMATED EFFECT ON REVENUE COLLECTIONS OF STATE OR LOCAL GOVERNMENTAL UNITS (Summary)

The revenue to support the program is from dedicated fees which are included as part of the proposed rule. This proposed fee is an increase in the department's revenue and needs to be included in the FY 94-95 budget.

There is no expected impact to local governmental units' revenue collections.

III. ESTIMATED COSTS AND/OR ECONOMIC BENEFITS TO DIRECTLY AFFECTED PERSONS OR NON-GOVERNMENTAL GROUPS (Summary)

The impact is felt by major stationary sources classified as "A" sources and "synthetic minor" sources in the Compliance Data System (CDS) maintained by the Air Quality Division of DEQ. The "A" major stationary sources will pay a fee of \$200 per facility and the "synthetic minor" major stationary sources will pay \$150 per facility as an annual registration fee. The fees will pay for a staff within DEQ to register the regulated facilities, to develop the future edit to LAC 33:III.Chapter 59 which will be needed when the federal government finalizes their process safety rule, and to assist the regulated community in their awareness of the rules requirements for compliance. The total impact is anticipated to be approximately \$150,000 per year.

Smaller facilities which are not defined as "A" or "synthetic minor" major stationary sources are not covered in this regulation.

IV. ESTIMATED EFFECT ON COMPETITION AND EMPLOYMENT (Summary)

There is no significant impact expected on competition or employment with the promulgation of this proposed rule.

Gus Von Bodungen
Assistant Secretary

David W. Hood
Senior Fiscal Analyst

3519 Patrick Street, Lake Charles, LA 70605; 3945 North I-10 Service Road West, Metairie, LA 70002; 100 Asma Boulevard, Suite 151, Lafayette, LA 70508 and also at the Office of the State Register, 1051 North Third Street, Room 512, Baton Rouge, LA 70802.

James B. Thompson, III
Assistant Secretary

**FISCAL AND ECONOMIC IMPACT STATEMENT
FOR ADMINISTRATIVE RULES
RULE TITLE: Emissions Reduction Credits Banking**

- I. ESTIMATED IMPLEMENTATION COSTS (SAVINGS) TO STATE OR LOCAL GOVERNMENTAL UNITS (Summary)
There is no significant impact to either costs or savings of local government resulting from the promulgation of this rule. State costs in FY 94-95 are estimated to increase \$60,300 to fund salaries and operating expenses for two additional positions necessary to process the expected applications.
- II. ESTIMATED EFFECT ON REVENUE COLLECTIONS OF STATE OR LOCAL GOVERNMENTAL UNITS (Summary)
There should be no effect on revenue collections of local government. Application fees are collected to support the state's cost of the program. State revenue is estimated to increase \$60,300 in FY 94-95 from a \$50 processing fee on an anticipated 1,206 applications.
- III. ESTIMATED COSTS AND/OR ECONOMIC BENEFITS TO DIRECTLY AFFECTED PERSONS OR NON-GOVERNMENTAL GROUPS (Summary)
The directly affected facilities will experience an increase in costs associated with the application fee. The affected facilities also have the potential of realizing economic benefit through the sale of those credits to other facilities wishing to expand in the ozone nonattainment area.
- IV. ESTIMATED EFFECT ON COMPETITION AND EMPLOYMENT (Summary)
There is no anticipated negative effect on competition or employment.

Gus Von Bodungen
Assistant Secretary

David W. Hood
Senior Fiscal Analyst

NOTICE OF INTENT

**Department of Environmental Quality
Office of Air Quality and Radiation Protection
Air Quality Division**

Reasonable Further Progress
(LAC 33:III.2120) (AQ86)

Under the authority of the Louisiana Environmental Quality Act, particularly R.S. 30:2051 et seq., and in accordance with the provisions of the Administrative Procedure Act, R.S. 49:950 et seq., the secretary gives notice that rulemaking procedures have been initiated to amend the Air Quality Division regulations, LAC 33:III.2120, (AQ86).

The purpose of promulgating this revision to Chapter 21 is to meet federal enforceability requirements for Air Toxics' Compliance Plans to demonstrate reasonable further progress.

Section 182(b)(1) of the CAAA requires all ozone nonattainment areas classified as moderate and above to submit a Reasonable Further Progress Plan by November 15, 1993, which describes how the area will achieve an actual VOC emission reduction of at least 15 percent during the first six years after enactment of the CAAA. The 1996 target level of emissions is the maximum amount of ozone season VOC emissions that can be emitted by an ozone nonattainment area in 1996 for that nonattainment area to be in compliance with the 15 percent Reasonable Further Progress Plan requirements. The banking rule is part of the contingency measures for the 15 percent VOC Reduction RFP.

These proposed regulations are to become effective upon publication in the *Louisiana Register*.

**Title 33
ENVIRONMENTAL QUALITY
Part III. Air**

**Chapter 21. Control of Emission of Organic Compounds
Subchapter A. General**

**§2120. Use of Incidental VOC Reductions to
Demonstrate Reasonable Further Progress**

A. Applicability. The provisions of this Section apply to sources designated pursuant to LAC 33:III.5101 and located in the ozone nonattainment area that includes the parishes of Ascension, East Baton Rouge, Iberville, Livingston, Pointe Coupee and West Baton Rouge.

B. Emission reductions of VOCs achieved after November 15, 1990, through compliance with air toxic maximum achievable control technology (MACT) standards and ambient air standards (AAS) pursuant to LAC 33:III.Chapter 51 may be utilized by the Air Quality Division where necessary to demonstrate reasonable further progress (RFP) in accordance with Section 182(b)(1) of the Clean Air Act Amendments (CAAA) of 1990. Emission reductions available for use shall be identified by source and tonnage in the 15 percent VOC Reduction State Implementation Plan prepared pursuant to Section 182 of the CAAA.

C. The owner or operator of each source so identified in the State Implementation Plan (SIP) shall submit a permit application to incorporate VOC emission reduction measures into the permit no later than February 15, 1995. The permit application shall contain all information required by LAC 33:III.517, including all information relative to the VOC emission reductions to be obtained through compliance with MACT and AAS. The permit application shall also include a compliance schedule for obtaining VOC emission reductions by November 15, 1996, as set forth by the SIP through the application of MACT (or compliance with AAS) as determined by the department pursuant to LAC 33:III.Chapter 51, and shall include compliance provisions specific to the source, including requirements and deadlines for compliance certification, testing, monitoring, reporting, and recordkeeping, which will meet the criteria specified in 40 CFR 70.6(a)(3) and LAC 33:III.507.H and which will assure that the reductions are maintained. The compliance schedule

will have the force of a regulation pending issuance of a permit. Failure to comply with the provisions of the compliance schedule once approved by the department may result in enforcement action by EPA or by DEQ pursuant to R.S. 30:2025.

D. Permit limits, terms, and conditions reflecting the emission reductions and corresponding compliance schedules and compliance measures shall be incorporated in a federally enforceable permit issued by the department in accordance with LAC 33:III.Chapter 5 no later than February 15, 1997.

AUTHORITY NOTE: Promulgated in accordance with R.S. 30:2054.

HISTORICAL NOTE: Promulgated by the Department of Environmental Quality, Office of Air Quality and Radiation Protection, Air Quality Division, LR 20:

A public hearing will be held on January 24, 1994, at 1:30 p.m. in the Maynard Ketcham Building, (Room 326), 7290 Bluebonnet Boulevard, Baton Rouge, LA. Interested persons are invited to attend and submit oral comments on the proposed amendments. Should individuals with a disability need an accommodation in order to participate please contact David Hughes at the address given below or at (504)765-0399.

All interested persons are invited to submit written comments on the proposed regulations. Such comments should be submitted no later than Tuesday, January 31, 1994, at 4:30 p.m., to David Hughes, Enforcement and Regulatory Compliance Division, Box 82282, Baton Rouge, LA, 70884-2282 or to 7290 Bluebonnet Boulevard, Fourth Floor, Baton Rouge, LA, 70810 or to FAX (504)765-0486. Commentors should reference this proposed regulation by Log AQ86.

James B. Thompson, III
Assistant Secretary

FISCAL AND ECONOMIC IMPACT STATEMENT FOR ADMINISTRATIVE RULES

RULE TITLE: Reasonable Further Progress

I. ESTIMATED IMPLEMENTATION COSTS (SAVINGS) TO STATE OR LOCAL GOVERNMENTAL UNITS (Summary)

There is no significant impact to either cost or savings resulting from the amendment of this rule.

II. ESTIMATED EFFECT ON REVENUE COLLECTIONS OF STATE OR LOCAL GOVERNMENTAL UNITS (Summary)

There is no revenue collection associated with this rule.

III. ESTIMATED COSTS AND/OR ECONOMIC BENEFITS TO DIRECTLY AFFECTED PERSONS OR NON-GOVERNMENTAL GROUPS (Summary)

There is no estimated cost and/or economic benefits to directly affected persons or non-governmental groups.

IV. ESTIMATED EFFECT ON COMPETITION AND EMPLOYMENT (Summary)

There is no impact on competition and employment.

Gus Von Bodungen
Assistant Secretary

David W. Hood
Senior Fiscal Analyst

NOTICE OF INTENT

Department of Environmental Quality Office of Air Quality and Radiation Protection Air Quality Division

Standards of Performance for New Stationary Sources (LAC 33:III. Chapter 31) (AQ69)

Under the authority of the Louisiana Environmental Quality Act, particularly R.S. 30:2051 et seq., and in accordance with the provisions of the Administrative Procedure Act, R.S. 49:950, et seq., the secretary gives notice that rulemaking procedures have been initiated to amend the Air Quality Division Regulations, LAC 33:III.Chapter 31.

The proposed changes to LAC 33:III.Chapter 31 reflect updates to Subchapter A: General Provisions and Modifications, that have been promulgated in the various New Source Performance Standards. These include changes to Sections 3133, Incorporations by Reference; 3155, Standards of Performance for Small Industrial-Commercial-Institutional Steam Generating Units (Subpart Dc); 3550, Applicability and Designation of Affected Facility; and 3741, Standards: Closed Vent Systems and Control Devices. Section 3134, Emissions and Compliance Times (Subparts C, Ca and Cb) is created.

These proposed changes have already been promulgated by the USEPA under 40 CFR 60 Subpart A. Promulgating the proposed changes to LAC 33:III.Chapter 31 will allow the DEQ to enforce these changes.

These proposed regulations are to become effective upon publication in the *Louisiana Register*.

A public hearing will be held on January 24, 1994, at 1:30 p.m. in the Maynard Ketcham Building, Room 326, 7290 Bluebonnet Boulevard, Baton Rouge, LA. Interested persons are invited to attend and submit oral comments on the proposed amendments. Should individuals with a disability need an accommodation in order to participate please contact David Hughes at the address given below or at (504)765-0399.

All interested persons are invited to submit written comments on the proposed regulations. Such comments should be submitted no later than Monday, January 31, 1994, at 4:30 p.m., to David Hughes, Enforcement and Regulatory Compliance Division, Box 82282, Baton Rouge, LA, 70884-2282 or to 7290 Bluebonnet Boulevard, Fourth Floor, Baton Rouge, LA, 70810 or to FAX number (504)765-0486. Commentors should reference this proposed regulation by Log AQ69. Check or money order is required in advance for each copy of AQ69.

This proposed regulation is available for inspection at the following DEQ locations from 8 a.m. until 4:30 p.m.: 7290 Bluebonnet Boulevard, Fourth Floor, Baton Rouge, LA 70810; 804 31st Street, Monroe, LA 71203; State Office Building, 1525 Fairfiels Avenue, Shreveport, LA 71101; 3510 Patrick Street, Lake Charles, LA 70605; 3945 North I-10 Service Road West, Metairie, LA 70002; 100 Asma Boulevard, Suite 151, Lafayette, LA 70508; and at the Office of the State Register, 1051 North Third Street, Room 512, Baton Rouge, LA 70802.

James B. Thompson, III
Assistant Secretary

**FISCAL AND ECONOMIC IMPACT STATEMENT
FOR ADMINISTRATIVE RULES
RULE TITLE: Standards of Performance for New Stationary
Sources (LAC 33:III.Chapter 31)**

- I. ESTIMATED IMPLEMENTATION COSTS (SAVINGS) TO STATE OR LOCAL GOVERNMENTAL UNITS (Summary)
There aren't any costs or savings expected from this proposal.
- II. ESTIMATED EFFECT ON REVENUE COLLECTIONS OF STATE OR LOCAL GOVERNMENTAL UNITS (Summary)
No impact is expected on revenue collections.
- III. ESTIMATED COSTS AND/OR ECONOMIC BENEFITS TO DIRECTLY AFFECTED PERSONS OR NON-GOVERNMENTAL GROUPS (Summary)
No estimated costs and/or economic benefits are expected from this proposal.
- IV. ESTIMATED EFFECT ON COMPETITION AND EMPLOYMENT (Summary)
There isn't any anticipated effect on competition and employment.

Gus Von Bodungen
Assistant Secretary

David W. Hood
Senior Fiscal Analyst

NOTICE OF INTENT

**Department of Environmental Quality
Office of Solid and Hazardous Waste
Underground Storage Tank Division**

UST Registration (LAC 33:XI.301)(UT05L)

Under the authority of the Louisiana Environmental Quality Act, particularly R.S. 30:2001 et seq., and in accordance with the provisions of the Administrative Procedure Act, R.S. 49:950, et seq., the secretary gives notice that rulemaking procedures have been initiated to amend the Underground Storage Tank Division Regulations, LAC 33:XI.301 (UT05L).

This rule will reinstate provisions of the regulations which were unintentionally deleted due to a typographical error made at the time the Underground Storage Tank Regulations were amended in July, 1992. This language has been in effect since July, 1990. No new language is proposed. This rule will require that 1) new underground storage tanks (USTs) are registered within 30 days; 2) owners certify that USTs were installed properly; 3) installers certify that UST(s) were installed in accordance with the regulations and provide his/her DEQ-issued certificate number on the registration form; 4) persons acquiring USTs register within 30 days, and persons selling USTs notify the DEQ within 30 days; and 5) owner/operators not allow the placement of a regulated substance into a new UST system.

These proposed regulations are to become effective upon publication in the *Louisiana Register*.

Title 33

ENVIRONMENTAL QUALITY

Part XI. Underground Storage Tanks

**Chapter 3. Registration Requirements,
Standards, and Fee Schedule**

§301. Registration Requirements

* * *

[See Prior Text in A.1-3]

B. New UST Systems. Upon the effective date of these regulations, all owners of new UST systems (as defined in LAC 33:XI.103) must, within 30 days of bringing such tanks into use, register them on a form approved by the department. The following registration requirements apply to new UST systems:

1. All owners of new UST systems must certify, in the space provided on the department's approved registration form, compliance with the following requirements:

- a. tank and piping installation in accordance with LAC 33:XI.303.A.4;
- b. cathodic protection of steel tanks and piping in accordance with LAC 33:XI.303.A.1-2;
- c. financial responsibility requirements under LAC 33:XI.Chapter 11; and
- d. release detection requirements under LAC 33:XI.703.A-C.

2. All owners of new UST systems must ensure that the installer certifies on the registration form that the methods used to install the tanks and piping comply with the requirements of LAC 33:XI.303.A.4.a. Beginning January 20, 1992, registration forms shall include the name and department-issued certificate number of the individual exercising supervisory control over installation critical junctures (as defined in LAC 33:XI.1303) of a UST system.

3. No owner or operator shall allow a regulated substance to be placed into a new UST system that has not been registered.

C. All UST Systems. Beginning on the effective date of these regulations, any person who sells a tank intended to be used as a UST must notify the purchaser of that tank of the owner's registration obligations under this Section's requirements, specifically:

1. Any person who sells a UST system shall so notify the department in writing within 30 days after the date of the transaction.

2. Any person who acquires a UST system shall submit an amended registration form within 30 days after the date of acquisition.

3. A current copy of the registration form must be kept on-site or at the nearest staffed facility.

AUTHORITY NOTE: Promulgated in accordance with R.S. 30:2001 et seq.

HISTORICAL NOTE: Promulgated by the Department of Environmental Quality, Office of Solid and Hazardous Waste, Underground Storage Tank Division, LR 11:1139 (December 1985), amended LR 16:614 (July 1990), LR 17:658 (July 1991), LR 18:727 (July 1992), LR 20:

A public hearing will be held on January 24, 1994, at 1:30 p.m. in the Maynard Ketcham Building, Room 326, 7290 Bluebonnet Boulevard, Baton Rouge, LA.

Interested persons are invited to attend and submit oral comments on the proposed amendments. Should individuals with a disability need an accommodation in order to participate please contact David Hughes at the address given below or at (504)765-0399.

All interested persons are invited to submit written comments on the proposed regulations. Such comments

should be submitted no later than Tuesday, January 31, 1994, at 4:30 p.m., to David Hughes, Enforcement and Regulatory Compliance Division, Box 82282, Baton Rouge, LA, 70884-2282 or to 7290 Bluebonnet Boulevard, Fourth Floor, Baton Rouge, LA, 70810 or to FAX (504)765-0486. Commentors should reference this proposed regulation by Log UT05L.

James B. Thompson, III
Assistant Secretary

**FISCAL AND ECONOMIC IMPACT STATEMENT
FOR ADMINISTRATIVE RULES
RULE TITLE: UST Registration (LAC:XI.301)**

- I. ESTIMATED IMPLEMENTATION COSTS (SAVINGS) TO STATE OR LOCAL GOVERNMENTAL UNITS (Summary)
There will be no implementation costs or savings to state or local government as a result of this rule.
- II. ESTIMATED EFFECT ON REVENUE COLLECTIONS OF STATE OR LOCAL GOVERNMENTAL UNITS (Summary)
There will be no significant effect on revenue collections of state or local governmental units.
- III. ESTIMATED COSTS AND/OR ECONOMIC BENEFITS TO DIRECTLY AFFECTED PERSONS OR NON-GOVERNMENTAL GROUPS (Summary)
There will be no significant cost and/or economic benefits to directly affected persons or non-governmental groups.
- IV. ESTIMATED EFFECT ON COMPETITION AND EMPLOYMENT (Summary)
There will be no significant effect on competition or employment.

Glenn A. Miller
Assistant Secretary

David W. Hood
Senior Fiscal Analyst

NOTICE OF INTENT

**Department of Environmental Quality
Office of Solid and Hazardous Waste
Underground Storage Tank Division**

UST Registration (Federal)
(LAC 33:XI.301) (UT05F)

Under the authority of the Louisiana Environmental Quality Act, particularly R.S. 30:2001 et seq., and in accordance with the provisions of the Administrative Procedure Act, R.S. 49:950 et seq., the secretary gives notice that rulemaking procedures have been initiated to amend the Underground Storage Tank Division Regulations, LAC 33:XI.301, (UT05F).

This rule will reinstate provisions of the regulations which were unintentionally deleted due to a typographical error made at the time the underground storage tank regulations were amended in July, 1992. This language has been in effect since July, 1990. No new language is proposed. This rule will require that 1) new underground storage tanks (USTs) are registered within 30 days; 2) owners certify that USTs were

installed properly; 3) installers certify that USTs were installed in accordance with the regulations; and 4) persons acquiring USTs register the tanks within 30 days.

These proposed regulations are to become effective upon publication in the *Louisiana Register*.

Title 33

ENVIRONMENTAL QUALITY

Part XI. Underground Storage Tanks

Chapter 3. Registration Requirements, Standards, and Fee Schedule

§301. Registration Requirements

* * *

[See Prior Text in A.1-3]

B. New UST Systems. Upon the effective date of these regulations, all owners of new UST systems (as defined in LAC 33:XI.103) must, within 30 days of bringing such tanks into use, register them on a form approved by the department. The following registration requirements apply to new UST systems:

1. All owners of new UST systems must certify, in the space provided on the department's approved registration form, compliance with the following requirements:
 - a. tank and piping installation in accordance with LAC 33:XI.303.A.4;
 - b. cathodic protection of steel tanks and piping in accordance with LAC 33:XI.303.A.1-2;
 - c. financial responsibility requirements under LAC 33:XI.Chapter 11; and
 - d. release detection requirements under LAC 33:XI.703.A-C.

2. All owners of new UST systems must ensure that the installer certifies on the registration form that the methods used to install the tanks and piping comply with the requirements of LAC 33:XI.303.A.4.a.

C. All UST Systems

1. Beginning on the effective date of these regulations, any person who sells a tank intended to be used as a UST must notify the purchaser of that tank of the owner's registration obligations under this Section's requirements.

2. Any person who acquires a UST system shall submit an amended registration form within 30 days after the date of acquisition.

AUTHORITY NOTE: Promulgated in accordance with R.S. 30:2001 et seq.

HISTORICAL NOTE: Promulgated by the Department of Environmental Quality, Office of Solid and Hazardous Waste, Underground Storage Tank Division, LR 11:1139 (December 1985), amended LR 16:614 (July 1990), LR 17:658 (July 1991), LR 18:727 (July 1992), LR 20:

A public hearing will be held on January 24, 1994, at 1:30 p.m. in the Maynard Ketcham Building, (Room 326), 7290 Bluebonnet Boulevard, Baton Rouge, LA. Interested persons are invited to attend and submit oral comments on the proposed amendments. Should individuals with a disability need an accommodation in order to participate please contact David Hughes at the address given below or at (504)765-0399.

All interested persons are invited to submit written comments on the proposed regulations. Such comments should be submitted no later than Tuesday, January 31, 1994,

at 4:30 p.m., to David Hughes, Enforcement and Regulatory Compliance Division, Box 82282, Baton Rouge, LA, 70884-2282 or to 7290 Bluebonnet Boulevard, Fourth Floor, Baton Rouge, LA, 70810 or to FAX (504)765-486. Commentors should reference this proposed regulation by Log UT05F.

James B. Thompson, III
Assistant Secretary

**FISCAL AND ECONOMIC IMPACT STATEMENT
FOR ADMINISTRATIVE RULES
RULE TITLE: UST Registration (Federal)**

- I. ESTIMATED IMPLEMENTATION COSTS (SAVINGS) TO STATE OR LOCAL GOVERNMENTAL UNITS (Summary)
There will be no implementation costs or savings to state or local government as a result of this rule.
- II. ESTIMATED EFFECT ON REVENUE COLLECTIONS OF STATE OR LOCAL GOVERNMENTAL UNITS (Summary)
There will be no effect on revenue collections of state or local governmental units.
- III. ESTIMATED COSTS AND/OR ECONOMIC BENEFITS TO DIRECTLY AFFECTED PERSONS OR NON-GOVERNMENTAL GROUPS (Summary)
There will be no cost and/or economic benefits to directly affected persons or non-governmental groups.
- IV. ESTIMATED EFFECT ON COMPETITION AND EMPLOYMENT (Summary)
There will be no effect on competition or employment.

Glenn A. Miller
Assistant Secretary

David W. Hood
Senior Fiscal Analyst

NOTICE OF INTENT

**Department of Environmental Quality
Office of Water Resources
Water Quality Management Division**

Surface Water Quality Standards
(LAC 33:IX.Chapter 11) (WP12)

Under the authority of the Louisiana Environmental Quality Act, particularly R.S. 30:2074.B.(1), and in accordance with the provisions of the Administrative Procedure Act, R.S. 49:950, et seq., the secretary gives notice that rulemaking procedures have been initiated to amend the Office of Water Resources, LAC 33:IX.Chapter 11, Surface Water Quality Standards (Log WP12).

The water quality standards establish provisions for the protection of instream water quality and consist of policy statements, water use designation, and numerical and narrative criteria which set limits for various water quality parameters. This proposed revision to the 1989 standards would consist of amending much of that current document, with some sections receiving more detailed revision than other sections. Proposed

revision includes (1) the addition of five new definitions, (2) the clarification of designated uses and water body exception language, (3) the addition of language for allowing variances and compliance schedules, (4) the addition of a subcategory of limited fish and wildlife propagation use, (5) additional narrative statement for biological and aquatic community integrity, (6) revision of the numerical criteria with current data, (7) revision of mixing zones and flow application, and (8) revision of numerical criteria and designated uses table. The water quality standards described in the document are applicable to the ambient surface waters of streams and other waterbodies of the state and do not apply to effluents or groundwaters.

Federal law governing water quality standards requires that states review and revise as appropriate their water quality standards every three years [Water Quality Act of 1987 PL 100-4 Section 303(c)].

These proposed regulations are to become effective on April 20, 1994, or upon publication in the *Louisiana Register*.

A public hearing will be held on January 28, 1994, at 1:30 p.m. in the Maynard Ketcham Building, Room 326, 7290 Bluebonnet Boulevard, Baton Rouge, LA. Interested persons are invited to attend and submit oral comments on the proposed amendments. Should individuals with a disability need an accommodation in order to participate please contact David Hughes at the address given below or at (504) 765-0399.

All interested persons are invited to submit written comments on the proposed regulations. Such comments should be submitted no later than February 11, 1994, at 4:30 p.m., to David Hughes, Enforcement and Regulatory Compliance Division, Box 82282, Baton Rouge, LA, 70884-2282 or to 7290 Bluebonnet Boulevard, Fourth Floor, Baton Rouge, LA, 70810 or to FAX number (504) 765-0486. Commentors should reference this proposed regulation by the Log WP12. Check or money order is required in advance for each copy of WP12.

This proposed regulation is available for inspection at the following DEQ locations from 8 a.m. until 4:30 p.m.: 7290 Bluebonnet Boulevard, Fourth Floor, Baton Rouge, LA 70810; 804 31st Street, Monroe, LA 71203; State Office Building, 1525 Fairfield Avenue, Shreveport, LA 71101; 3519 Patrick Street, Lake Charles, LA 70605; 3945 North I-10 Service Road West, Metairie, LA 70002; 100 Asma Boulevard, Suite 151, Lafayette, LA 70508 and at the Office of the State Register, 1051 North Third Street, Baton Rouge, LA 70802.

James B. Thompson, III
Assistant Secretary

**FISCAL AND ECONOMIC IMPACT STATEMENT
FOR ADMINISTRATIVE RULES
RULE TITLE: Surface Water Quality Standards
(LAC 33:IX.Chapter 11) (WP12)**

- I. ESTIMATED IMPLEMENTATION COSTS (SAVINGS) TO STATE OR LOCAL GOVERNMENTAL UNITS (Summary)
No significant effect of this proposed rule on state or local governmental expenditures is anticipated. Some local municipal facilities may experience a slight increase in operating and

system upgrade costs, depending on the discharge of business and industrial facilities into their treatment systems. However, these costs can be conveyed through increased user fees to the business and industrial facilities of concern. A significant amount of these costs to meet the new limits required by the proposed water quality standards are already required by the U.S. Environmental Protection Agency to meet permit technology limits.

II. ESTIMATED EFFECT ON REVENUE COLLECTIONS OF STATE OR LOCAL GOVERNMENTAL UNITS (Summary)

No significant effect on state or local governmental revenue collections is anticipated, except possibly at the local level where municipal facilities may raise user fees charged to business and industrial customers to cover their added costs, if any are incurred. Any increase in user fees possibly resulting from this rule would be site-specific and determined by individual discharger circumstances and cannot be estimated at this time. A possible long-term effect on governmental revenue collections is that better water quality may encourage businesses to expand or locate in Louisiana and may increase tourism with a resultant increase in state and local income tax collections.

III. ESTIMATED COSTS AND/OR ECONOMIC BENEFITS TO DIRECTLY AFFECTED PERSONS OR NON-GOVERNMENTAL GROUPS (Summary)

No significant costs to directly affected persons or non-governmental groups are anticipated. Members of the regulated community subject to these revised water quality standards may incur some additional costs due to requirements for increased controls on toxic substances to protect human health; however, these standards will not impose a significant increase in costs beyond that attributable to federally required permit requirements. Business and industrial users of municipal treatment facilities may experience a slight increase in user fees; however, these costs would be site-specific and determined by individual discharger circumstances and cannot be estimated at this time. Increases in costs beyond present or new federal requirements can be dealt with by practicing the use of source reduction or pollution prevention practices. The benefits of the revision include clarification of exact amounts allowed for discharge, thus eliminating some uncertainty in the permitting process, a decrease in costs to public water suppliers who must treat drinking water sources and supply potable water to approximately 1.5 million individuals, and giving DEQ and the public and industry clearer standards for surface water quality. Long-term benefits could include decreases in liability for dischargers of toxic substances and possible decreases in health care expenditures associated with exposure to levels of toxic substances of previously unquantifiable limits. Another benefit could be in the enhanced protection of Louisiana's lucrative seafood industry through the possible decrease in exposure to toxic substances within the ambient waters of the state.

IV. ESTIMATED EFFECT ON COMPETITION AND EMPLOYMENT (Summary)

Business may increase for equipment and treatment chemical suppliers and analytical laboratories. Comparable standards are, or soon will be, applicable in other heavily industrialized states. Competition with neighboring states will be minimal, since all states must satisfy EPA requirements. Achieving better water quality through the establishment of straightforward, scientifically sound guidelines can promote industrial development and expansion and increase employment in the long-run.

J. Dale Givens
Assistant Secretary

David W. Hood
Senior Fiscal Analyst

NOTICE OF INTENT

Office of the Governor Office of Veterans Affairs

Merchant Marine Bonus (LAC 4:VII.915)

The Office of Veterans Affairs advertises its intent to adopt the following rules relative to the payment of a bonus to certain Louisiana citizens who served on active duty as a member of the Merchant Marines in World War II. Pursuant to the authority and provisions of Act 90 of the 1993 Regular Legislative Session, a bonus in the amount of \$250 will be paid to these certain Louisiana citizens as authorized by the Act and the Office of Veterans Affairs shall have the authority for the distribution of the bonuses authorized. The executive director, with the approval of the Veterans Affairs Commission, shall make rules and regulations as necessary for the proper administration of this Section.

Title 4

ADMINISTRATION

Part VII. Governor's Office

Chapter 9. Veterans Affairs

Subchapter A. Veterans Affairs Commission

§915. World War II Merchant Marine Bonus Payments

A. Eligibility for the bonus shall be restricted to include only servicemembers who are Louisiana citizens and who served on active duty as a member of the Merchant Marines in World War II any time during the period between September 16, 1940, through July 25, 1947, and received an honorable discharge or to the unremarried surviving spouse of each such servicemember who died while serving on active duty in the Merchant Marines during said period. For the purpose of administering this Act, a citizen is defined as an individual who was a resident of Louisiana at the time of entry into the Merchant Marines.

B. Veteran must present proof of active duty and honorable discharge by submitting discharge papers (DD 214 or equivalent) to the Office of Veterans Affairs with the application for bonus payment. Unremarried surviving spouse must present proof of marriage and a report of casualty (DD 1300 or equivalent), or proof that veteran died of a service-connected disability between the dates of September 16, 1940, and July 25, 1947, as a result of active service in the Merchant Marines.

C. A former remarried surviving spouse is not eligible for the bonus payment. For the purpose of this Act, a surviving spouse does not regain entitlement if she later terminates a remarriage.

D. If there is no surviving veteran or unremarried surviving spouse, then no bonus shall be paid.

E. A claim must be received by the Office of Veterans Affairs on or before July 1, 1999, in order for a bonus to be paid.

F. If any veteran or unremarried surviving spouse herein entitled to a bonus has received a bonus or gratuitous payment from any other state prior to making application to the Office of Veterans Affairs, then the amount of the bonus or

gratuitous payment so received shall be deducted from the amount provided herein to be paid to each such person.

G. The bonuses and payments provided herein shall be completely exempt from all liability for any debt, tax, or obligation.

H. Bonus payments are not assignable.

I. Effective date for bonus applications shall be July 1, 1994.

AUTHORITY NOTE: Promulgated in accordance with Act 90, 1993 Regular Legislative Session.

HISTORICAL NOTE: Promulgated by the Office of the Governor, Office of Veterans Affairs, LR 20:

These proposed rules are to become effective on March 20, 1994, or upon publication in the *Louisiana Register*.

All interested persons are invited to submit written comments on the proposed rules. Such comments should be submitted no later than January 28, 1994, at 4:30 p.m., to Ernie P. Broussard, Executive Director, Box 94095, Capitol Station, Baton Rouge, LA 70804-9095, or to 1885 Wooddale Boulevard, Tenth Floor, Baton Rouge, LA 70806.

Ernie P. Broussard
Executive Director

FISCAL AND ECONOMIC IMPACT STATEMENT FOR ADMINISTRATIVE RULES

RULE TITLE: World War II Merchant Marine Bonus

I. ESTIMATED IMPLEMENTATION COSTS (SAVINGS) TO STATE OR LOCAL GOVERNMENTAL UNITS (Summary)

The Office of Veterans Affairs estimates that a maximum of 1,000 Merchant Marine veterans could qualify for the military bonus from the state of Louisiana. Act 90 of the 1993 Regular Legislative Session authorizes a \$250 payment per person, which amounts to \$250,000, plus an additional \$25,000 in administrative costs, totaling \$275,000 from the state general fund.

II. ESTIMATED EFFECT ON REVENUE COLLECTIONS OF STATE OR LOCAL GOVERNMENTAL UNITS (Summary)

There will be no effect on revenue collections of state or local governmental units.

III. ESTIMATED COSTS AND/OR ECONOMIC BENEFITS TO DIRECTLY AFFECTED PERSONS OR NON-GOVERNMENTAL GROUPS (Summary)

Affected persons will realize a direct cash benefit of \$250 per eligible person.

IV. ESTIMATED EFFECT ON COMPETITION AND EMPLOYMENT (Summary)

There will be no effect on competition and employment.

Ernie P. Broussard
Executive Director

John R. Rombach
Legislative Fiscal Officer

NOTICE OF INTENT

Office of the Governor Patient's Compensation Fund Oversight Board

Payment of Surcharges (LAC 37:III.711-713)

The Patient's Compensation Fund Oversight Board, under authority of the Louisiana Medical Malpractice Act, R.S. 40:1299.41 et seq., and in accordance with the Administrative Procedure Act, R.S. 49:950 et seq., advertises its intent to amend LAC 37:III.Chapter 7, as follows, which provides for and governs the payment of surcharges to the fund and the fund's right to seek penalties, interest and attorney's fees.

Title 37

INSURANCE

Part III. Patient's Compensation Fund Oversight Board Chapter 7. Surcharges

§711. Payment of Surcharges: Insurers

A. Applicable surcharges for enrollment with the fund shall be collected on behalf of the fund by commercial professional health care liability insurance companies and approved self-insurance trust funds from insured health care providers electing to enroll with the fund. Such surcharges shall be collected by such insurers and funds at the same time and on the same basis as such insurers' collection of premiums from such insureds. Surcharges collected by commercial insurance underwriters and funds on behalf of the fund shall be due and payable and remitted to the fund by commercial insurance underwriters and funds within 45 days from the date on which such surcharges are collected from any insured. Remittance of surcharges to the fund shall be made in such form and accompanied by records in such form or on such forms as may be prescribed by the executive director so as to provide for proper accounting of remitted surcharges and the identity and class of health care providers on whose behalf such surcharges are remitted. Commercial professional health care liability insurance companies, commercial insurance underwriters and approved self-insurance trust funds remitting surcharges to the fund shall certify to the fund, at the time of remitting such surcharge to the fund, the date that the surcharges were collected by them from the health care providers. The payment of surcharges by an approved self-insurance trust fund that does not collect premiums from insureds will be governed by §713 hereof.

B. Failure of the commercial professional health care liability insurers, commercial insurance underwriters, and approved self-insurance trust funds to remit payment within 45 days of collecting such annual surcharge shall subject the commercial professional liability insurers, commercial insurance underwriters, and approved self-insurance trust funds to a penalty of 12 percent of the annual surcharge and all reasonable attorney's fees. Upon the failure of the commercial professional health care liability insurers, commercial insurance underwriters and approved self-insurance trust funds to remit as provided in this Section, the board may institute legal proceedings to collect the surcharge, together with penalties, legal interest, and attorney's fees.

AUTHORITY NOTE: Promulgated in accordance with R.S. 40:1299.44D.(3).

HISTORICAL NOTE: Promulgated by the Office of the Governor, Patient's Compensation Fund Oversight Board, LR 18:176 (February 1992), amended LR 20:

§713. Payment of Surcharges: Self-insureds

A. Not less than 60 days prior to the termination of enrollment of a health care provider, the executive director shall cause each self-insured health care provider enrolled with the fund and each self-insured health care provider having been approved for enrollment with the fund, to receive a statement of surcharges due the fund by the health care provider for enrollment with the fund during the succeeding enrollment year.

B. Surcharges due the fund by self-insured health care providers for enrollment with the fund for an enrollment year shall be due and payable to the fund prior to the effective date of the coverage, or renewal of coverage, to which the surcharge applies. Remittance of surcharges to the fund shall be made in such form and accompanied by records in such form or on such forms as may be prescribed by the executive director so as to provide for proper accounting of remitted surcharges and the identity and class of health care provider remitting surcharges.

C. - E. Repealed.

AUTHORITY NOTE: Promulgated in accordance with R.S. 40:1299.44D.(3).

HISTORICAL NOTE: Promulgated by the Office of the Governor, Patient's Compensation Fund Oversight Board, LR 18:176 (February 1992), amended LR 20:

Interested persons may submit inquiries and written comments on the amended rules until 4:30 p.m., January 20, 1994, to Suanne Grosskopf, Executive Director, Patient's Compensation Fund Oversight Board, 200 Lafayette Street, Number 600, Baton Rouge, LA 70801 and/or to Larry M. Roedel, General Counsel, Patient's Compensation Fund Oversight Board, 8440 Jefferson Highway, Third Floor, Baton Rouge, LA 70809.

Suanne Grosskopf
Executive Director

**FISCAL AND ECONOMIC IMPACT STATEMENT
FOR ADMINISTRATIVE RULES
RULE TITLE: Payment of Surcharges**

I. ESTIMATED IMPLEMENTATION COSTS (SAVINGS) TO STATE OR LOCAL GOVERNMENTAL UNITS (Summary)

The costs to implement the amendments will include printing, copy charges, and associated costs of publication, administrative overhead expenses and legal fees, all of which should not exceed \$1,500. This amount will be paid by the Patient's Compensation Fund, R.S. 40:1299.44 et seq., from statutory dedications, i.e., absorbed/paid from available monies in the budget FY 93-94. There is no need at this time for increased staff to handle the implementation of these amendments

II. ESTIMATED EFFECT ON REVENUE COLLECTIONS OF STATE OR LOCAL GOVERNMENTAL UNITS (Summary)

There is no material effect on the revenue collections of state

or local governmental units from implementation of these amendments pertaining to the Patient's Compensation Fund's right to seek penalties, interest and attorney's fees and to require health care liability insurers who collect and remit surcharges to the Patient's Compensation Fund to certify the date that the surcharges were collected from the health care providers.

III. ESTIMATED COSTS AND/OR ECONOMIC BENEFITS TO DIRECTLY AFFECTED PERSONS OR NON-GOVERNMENTAL GROUPS (Summary)

There are no estimated costs and/or economic benefits to directly affected persons or non-governmental groups. The proposed amendments pertain to the Patient's Compensation Fund's right to seek penalties, interest and attorney's fees and to require health care liability insurers who collect and remit surcharges to the Patient's Compensation Fund to certify the date that the surcharges were collected from the health care providers.

IV. ESTIMATED EFFECT ON COMPETITION AND EMPLOYMENT (Summary)

The Patient's Compensation Fund Oversight Board anticipates no effect on either competition or employment as a result of adopting the amendments.

Suanne Grosskopf
Executive Director

David W. Hood
Senior Fiscal Analyst

NOTICE OF INTENT

**Department of Health and Hospitals
Board of Examiners of Professional Counselors**

**Declaration of Practices and Procedures
(LAC 46:LX.Chapter 21, Appendix)**

In accordance with R.S. 37:1101-1115 et seq. and the Administrative Procedure Act, R.S. 49:950 et seq., notice is hereby given that the Board of Examiners for Licensed Professional Counselors is amending Title 46:LX, Chapter 21, Appendix.

**Title 46
PROFESSIONAL AND OCCUPATIONAL
STANDARDS**

**Part LX. Professional Counselors,
Board of Examiners of**

Chapter 21. Code of Conduct

Appendix

**Declaration of Practices and Procedures Statement
for Licensed Professional Counselors**

A. The following comprises the information that must be available in writing for each client seen by a licensed professional counselor/counselor intern in the state of Louisiana. Counselors must read and incorporate the Code of Conduct for Professional Counselors in their declaration statement.

1. LPC/counselor intern's name, mailing address, and telephone number.

2. Qualifications:

- a. include degrees earned and institution(s) attended;
- b. give licensure number, specifying the LPC Board of Examiners including address and telephone number as the grantor of license;

c. an individual under supervision must refer to him/herself as a counselor intern and include the name and address of his /her board-approved supervisor.

3. Counseling Relationship:

a. provide a general statement about the dynamics of the counseling relationship;

b. include general goals for clients.

4. Area of Expertise:

a. list areas of expertise such as career counseling, marriage and family counseling, adolescents, etc;

b. list national certifications in counseling.

5. Fee Scales:

a. list fees and describe billing policies;

b. describe policy on scheduling and breaking appointments;

c. state policy on insurance payments.

6. Explanation of the Types of Services Offered and Clients Served:

a. include the theoretical basis and the type of techniques and/or strategies used in therapy;

b. specify the modality used such as group and/or individual therapy;

c. specify the type(s) of clients served.

7. Code of Conduct: indicate that counselors are required by state law to adhere to the Code of Conduct for their practice which is determined by the Louisiana Licensing Board, and that a copy of this Code is available on request.

8. Privileged Communication: describe the rules governing privileged communication and include the limits of confidentiality.

9. Emergency Situations: describe policy for emergency client situations.

10. Client Responsibilities: list client responsibilities, i.e., clients are expected to follow office procedures for keeping appointments, clients must pay for services at the time of each visit, and clients must notify the counselor of any other ongoing professional mental health relationship. If a client is seeing another professional counselor (psychologist, board-certified social worker, etc.), then permission must be granted by the first therapist for the second to work with the same client. (See Code of Conduct)

11. Physical Health: suggest that client have a complete physical if he/she has not had one within the past year. Also have client list any medications that he/she may be taking.

12. Potential Counseling Risks: indicate that as a result of mental health counseling, the client may realize that he/she has additional issues which may not have surfaced prior to the onset of the counseling relationship. The counselor may also indicate possible risk within specific specialty areas (i.e., marriage and family - as one partner changes, additional strain may be placed on the marital relationship if the other partner refuses to work).

13. It is also required that a place be provided for the signatures of the counselor/counselor intern, the client(s), and the counselor intern's supervisor. A general statement

indicating that the client has read and understands the declaration statement and the date of the signature must also be included.

B. To practice mental health counseling in Louisiana the Licensed Professional Counselor must have a copy of his/her declaration statement on file in the LPC Board office. A current declaration statement must be attached to all license renewals. The counselor intern must include a copy of his/her declaration statement with his/her Registration of Supervision. The Code of Conduct can be duplicated for clients and additional copies are available from the board.

AUTHORITY NOTE: Promulgated in accordance with R.S. 37:1101-1115.

HISTORICAL NOTE: Promulgated by the Department of Health and Hospitals, Board of Examiners, of Professional Counselors, LR 15:627 (August 1989), amended LR 20:

Interested persons may submit comments on the proposed rule until 4:30 p.m., February 4, 1994 to: Lynn Tauzin Reed, Executive Director, Board of Examiners of Licensed Professional Counselors, 4664 Jamestown Avenue, Suite 125, Baton Rouge, LA 70808-3218.

Peter M. Emerson, Ed.D., LPC
Board Chair

**FISCAL AND ECONOMIC IMPACT STATEMENT
FOR ADMINISTRATIVE RULES
RULE TITLE: Declaration of Practices and Procedures
Statement for Licensed Professional Counselors**

I. ESTIMATED IMPLEMENTATION COSTS (SAVINGS) TO STATE OR LOCAL GOVERNMENTAL UNITS (Summary)

There will be no estimated implementation costs or savings to state or local government as a result of this rule.

II. ESTIMATED EFFECT ON REVENUE COLLECTIONS OF STATE OR LOCAL GOVERNMENTAL UNITS (Summary)

There will be no change in revenue collections due to this rule.

III. ESTIMATED COSTS AND/OR ECONOMIC BENEFITS TO DIRECTLY AFFECTED PERSONS OR NON-GOVERNMENTAL GROUPS (Summary)

It is estimated that there will be no change in costs and/or economic benefits to directly affected persons or non-governmental groups.

IV. ESTIMATED EFFECT ON COMPETITION AND EMPLOYMENT (Summary)

No effect on competition or employment is estimated.

Peter M. Emerson, Ed.D., LPC
Board Chair

David W. Hood
Senior Fiscal Analyst

NOTICE OF INTENT

Department of Health and Hospitals Office of Public Health

Tuberculosis Control Regulations

In accordance with the provisions of R.S. 49:950 et seq. of the Administrative Procedure Act, the state health officer and the Office of Public Health of the Department of Health and Hospitals hereby promulgate stringent tuberculosis control measures as mandated by Act No. 289 of the 1993 Regular Session amending and reenacting R.S. 40:4(A)(2)(c). These regulations are further authorized by R.S. 40:5(1) as amended by Act No. 180 of the 1993 Regular Session, and by R.S. 40:17 as amended by Act No. 190 of the 1993 Regular Session.

The Office of Public Health proposes to amend Chapters II, XVII, XVIII, XIX and XX of the Sanitary Code, to conform with Acts 180 and 190 of the 1993 Regular Legislative Session. This proposed rule deals with control of tuberculosis in Louisiana, specifically with issues of quarantine, infection control, tuberculin testing, and employee safety issues. There is also one unrelated paragraph from Chapter II (2:025-1) that is included to rectify a previous numbering error. This rule and its preceding legislation were developed in an effort to better control the spread of tuberculosis and decrease the development of resistant strains of the organism.

Copies of this proposed amendment can be obtained from the Office of Public Health at the address listed below and also from the Office of the State Register at 1051 North Third Street, Room 512, Baton Rouge, LA 70802.

Interested persons may submit written comments on the proposed rule until January 27, 1994 at the following address: Meg Lawrence, M.D., Medical Director, Tuberculosis Control Program, Office of Public Health, Box 60630, New Orleans, LA 70160.

Rose V. Forrest
Secretary

FISCAL AND ECONOMIC IMPACT STATEMENT FOR ADMINISTRATIVE RULES RULE TITLE: Tuberculosis Control

- I. ESTIMATED IMPLEMENTATION COSTS (SAVINGS) TO STATE OR LOCAL GOVERNMENTAL UNITS (Summary)
The expenditure of funds has already been voluntarily made by the departments or has been mandated by other agencies who accredit them. No other implementation costs are expected.
- II. ESTIMATED EFFECT ON REVENUE COLLECTIONS OF STATE OR LOCAL GOVERNMENTAL UNITS (Summary)
No effect on revenue collection is expected.
- III. ESTIMATED COSTS AND/OR ECONOMIC BENEFITS TO DIRECTLY AFFECTED PERSONS OR NON-GOVERNMENTAL GROUPS (Summary)
Non-accredited hospitals will need to install proper air-handling equipment in order to care for tuberculosis patients.

This will cost \$500-\$5,000 per room—only one room has to be equipped.

Healthcare students will have to pay to have a TB skin test placed (\$10-\$15). All medical and nursing students are already tested.

IV. ESTIMATED EFFECT ON COMPETITION AND EMPLOYMENT (Summary)

No effect is expected.

John Futrell
Deputy Secretary

David W. Hood
Senior Fiscal Analyst

NOTICE OF INTENT

Department of Health and Hospitals Office of the Secretary

DHH/LHCA Annual Service Agreement

Under authority of Act 390 of 1991 and in accordance with the provisions of R.S. 49:950 et seq., the Administrative Procedure Act, the Department of Health and Hospitals proposes to adopt the Annual Service Agreement. This service agreement for state fiscal year 1993-94 is entered into by the Department of Health and Hospitals (DHH) and the Louisiana Health Care Authority (LHCA) in compliance with R.S. 46:701 et seq., as amended and reenacted by Act 390 of 1991.

The full text of this proposed rule may be viewed in the Emergency Rule Section of this issue of the *Louisiana Register*.

Interested persons may submit written comments to the following address: Charles F. Castille, General Counsel, Department of Health and Hospitals, Box 3836, Baton Rouge, LA 70821. He is the person responsible for responding to inquires regarding this proposed rule.

Rose V. Forrest
Secretary
Health and Hospitals

William B. Cherry, M.D.
Chief Executive Officer
Health Care Authority

FISCAL AND ECONOMIC IMPACT STATEMENT FOR ADMINISTRATIVE RULES RULE TITLE: LHCA/DHH Annual Service Agreement for FY 93-94

- I. ESTIMATED IMPLEMENTATION COSTS (SAVINGS) TO STATE OR LOCAL GOVERNMENTAL UNITS (Summary)
There are no additional costs associated with this Service Agreement over and above the LHCA budget for FY 93-94. The agreement proposes no services in addition to those budgeted for the year. There is no fiscal impact associated with

the Annual Service Agreement between the Department of Health and Hospitals and the Louisiana Health Care Authority. The nature of this agreement is not such that funds are expended or revenues altered in consequence of its adoption. The service agreement is a device established by the legislature to assure that DHH and LHCA Medical Centers maintain a formal linkage with respect to the delivery and future planning of substantive programs and services in the hospitals. Act 390 of 1991 retained the DHH programmatic responsibility for indigent medical care, created a vendor-like relationship with the hospitals under the Authority, and required DHH to perform an oversight function with respect to service delivery. The service agreement will establish the ground rules of the ongoing relationship between DHH and the Authority, including the terms under which DHH will discharge its oversight responsibilities regarding service delivery during the course of the year. Ultimately, service levels are determined through the budget process. It is anticipated that the Annual Agreement will become a means to help create a consensus in support of service levels to be funded, as well as to provide a mutually agreeable basis for DHH monitoring of service delivery.

II. ESTIMATED EFFECT ON REVENUE COLLECTIONS OF STATE OR LOCAL GOVERNMENTAL UNITS (Summary)

This service agreement will have no impact on revenues.

III. ESTIMATED COSTS AND/OR ECONOMIC BENEFITS TO DIRECTLY AFFECTED PERSONS OR NON-GOVERNMENTAL GROUPS (Summary)

There are no costs or benefits to non-governmental persons or entities.

IV. ESTIMATED EFFECT ON COMPETITION AND EMPLOYMENT (Summary)

There are no effects on competition or employment.

Rose V. Forrest
Secretary

David W. Hood
Senior Fiscal Analyst

NOTICE OF INTENT

**Department of Health and Hospitals
Office of the Secretary
Bureau of Health Services Financing**

Drug Screening Inspection and Certification Program

The Department of Health and Hospitals, Office of the Secretary, Bureau of Health Services Financing proposes to amend the current regulations governing approval of drug screening laboratories in accordance with the provisions of the Administrative Procedure Act, R.S. 49:950 et seq. Pursuant to Act 1036 of the 1990 Legislature, the bureau adopted a rule on November 20, 1991 specifying the regulations to govern its approval of all drug screening laboratories in this state. The rule was published in the November 20, 1991 issue of the *Louisiana Register* (Volume 17, No. 11, pages 1109-1114). Subsequently, Act 878 of the 1993 Regular Session of Louisiana Legislature amended R.S. 49:1008(A) relative to the department's approval of drug testing in this state. This Act mandates that the department inspect and certify screening laboratories performing initial drug testing and authorizes the

imposition of a fee not to exceed \$250 to fund the certification and inspection process. In addition, the bureau has determined the need to revise current regulations concerning the required time period from receipt of the specimen for testing and the actual text performance on that specimen in certain proficiency testing requirements. Therefore, the bureau proposes to adopt the following rule.

PROPOSED RULE

The Bureau of Health Services Financing shall amend its current regulations governing the inspection, approval and certification of drug screening laboratories conducting initial drug testing.

I. Fees. An annual inspection fee of \$250 will be levied on drug screening laboratories.

II. Programmatic Changes

A. Initial screening shall be completed within two working days following receipt of the specimen. If initial screening cannot be completed within two working days, the specimen shall not be accepted and shall be sent to another laboratory for screening.

B. Proficiency Testing

1. The laboratory must assure that proficiency testing samples are analyzed using the same techniques as those employed for screening unknown specimens.

2. The laboratory must maintain an overall testing event score of 100 percent for performance to be considered satisfactory.

3. Laboratories may participate in commercially available proficiency testing programs that are currently available. Examples of such programs include the College of American Pathologists (CAP), American Association of Clinical Chemistry (AACC), Forensic Urine Drug Testing or Urine Toxicology and American Association of Bioanalysts, (AAB).

Interested persons may submit written comments to the following address: Thomas D. Collins, Box 91030, Baton Rouge, LA 70821-0629. A public hearing on this proposed rule will be held on Tuesday, January 25, 1994 in the Department of Transportation and Development Auditorium, First Floor, 1201 Capitol Access Road, Baton Rouge, LA at 9:30 a.m. All interested persons will be afforded an opportunity to submit data, views or arguments, orally or in writing at the public hearing.

Rose V. Forrest
Secretary

**FISCAL AND ECONOMIC IMPACT STATEMENT
FOR ADMINISTRATIVE RULES**

**RULE TITLE: Drug Screening Inspection
and Certification**

I. ESTIMATED IMPLEMENTATION COSTS (SAVINGS) TO STATE OR LOCAL GOVERNMENTAL UNITS (Summary)

It is estimated that implementation of this proposed rule will increase state expenditures by \$150 for SFY 1994.

II. ESTIMATED EFFECT ON REVENUE COLLECTIONS OF STATE OR LOCAL GOVERNMENTAL UNITS (Summary)

It is estimated that implementation of this proposed rule will

generate \$5,100 for SFY 94 and \$5,500 for SFY 95 and \$5,750 for SFY 96.

III. ESTIMATED COSTS AND/OR ECONOMIC BENEFITS TO DIRECTLY AFFECTED PERSONS OR NON-GOVERNMENTAL GROUPS (Summary)

Persons undergoing pre-employment drug testing will benefit from the inspection and certification of the drug screening laboratories. These laboratories will have to pay the full amount of the state revenues expected to be received from this proposed rule.

IV. ESTIMATED EFFECT ON COMPETITION AND EMPLOYMENT (Summary)

There is no estimated effect on competition and employment.

Thomas D. Collins
Director

David W. Hood
Senior Fiscal Analyst

NOTICE OF INTENT

Department of Health and Hospitals Office of the Secretary Bureau of Health Services Financing

Facility Need Review - Downsizing ICF/MR Facilities

The department is proposing to adopt the following rule in accordance with the provisions of the Administrative Procedure Act, R.S. 49:950 et seq., and pursuant to R.S. 40:2116. The rules governing the Facility Need Review Process, as originally published in the January 20, 1991 issue of the *Louisiana Register* (Vol. 17, No. 1, pages 61-67) and in subsequent volumes as required by amendments thereto, are being amended. Amendments which generally address the provisions of this proposed rule were adopted through emergency rulemaking on November 1, 1993 and were published in the November 20, 1993 issue of the *Louisiana Register* (Vol. 19 No. 20, pages 1407-1408).

The department continues to strive toward providing an array of residential living options designed to prevent, remediate, or reduce the effects of developmental delays and disabilities. To enhance this array of services, a mechanism is needed for requesting and evaluating proposals to develop beds made available by downsizing large state-owned residential facilities. Therefore, the Bureau of Health Services Financing is proposing to change the Facility Need Review Process to allow for the issuance of solicitations of offers, as well as the evaluation of proposal offerings for these community and group home beds. The bureau is also proposing to change the Facility Need Review Process with respect to which Regional Office for Citizens with Developmental Disabilities reviews and evaluates proposals to downsize private facility beds to privately owned group or community homes and state-owned facility beds downsized to state-owned group or community homes.

PROPOSED RULE

The Bureau of Health Services Financing hereby proposes to repeal Section 12502, Subsection A, Number 6 and adopt the following as Section 12502, Subsection A, Number 6:

Exception for beds approved from downsizing large residential ICF/MRs (16 or more beds).

a. A facility with 16 or more beds which voluntarily downsizes its enrolled bed capacity in order to establish a group or community home will be exempt from the Facility Need Review application process and from the bed need criteria. Beds in group and community homes which are approved under this exception are not included in the bed-to-population ratio or occupancy data for group and community homes approved under the Facility Need Review Program.

b. Any enrolled beds in the large facility will be disenrolled from the Title XIX Program upon enrollment of the same number of group or community home beds.

c. Prior approval of all Medicaid recipients for admission to facilities in beds approved to meet a specific disability need identified in a solicitation of offers issued by the department is required from the Office of Citizens with Developmental Disabilities before admission.

d. State-Owned Facility Beds Downsized to Develop Community or Group Home Beds not Owned by the State.

i. When the department intends to downsize the enrolled bed capacity of a state-owned facility with 16 or more beds in order to develop one or more group or community home beds not to be owned by the state, a Solicitation of Offers (SOO) will be issued. The SOO will indicate the parish or region in need of beds, the number of beds needed, the date by which the beds are needed to be available to the target population (enrolled in Medicaid), and the factors which the department considers relevant in determining the need for these beds.

ii. The SOO will be issued through the press (nearest major metropolitan newspaper), and will specify the dates during which the department will accept applications.

iii. No applications will be accepted under these provisions unless the department declares a need and issues a solicitation. Applications will be accepted for expansion of existing facilities and/or for the development of new facilities.

iv. Once submitted, an application cannot be changed; additional information will not be accepted.

v. The department will review the proposals and independently evaluate and assign points to each of the following 10 items on the application for the quality and adequacy of the response to meet the need of the project:

- (a) work plan for medicaid certification;
- (b) availability of the site for the proposal;
- (c) relationship or cooperative agreements with other health care providers;
- (d) accessibility to other health care providers;
- (e) availability of funds; financial viability;
- (f) experience and availability of key personnel;
- (g) range of services, organization of services and program design;
- (h) methods to achieve community integration;
- (i) methods to enhance and assure quality of life;
- (j) plan to ensure client rights, maximize client choice and family involvement.

vi. A score of 0-4 will be given to the applicant's response to each item using the following guideline:

- 0 = inadequate response
- 1 = marginal response
- 2 = satisfactory response
- 3 = above average response
- 4 = outstanding response

vii. If there is a tie for highest score for a specific facility/beds for which the department has solicited offers, a comparative review of the top scoring proposals will be conducted. This comparative review will include prior compliance history. In the case of a tie, the department will make a decision to approve one of the top scoring applications based on comparative review of the proposals.

viii. If no proposals are received which adequately respond to the need, the department may opt not to approve an application.

ix. At the end of the 90-day review period, each applicant will be notified of the department's decision to approve or disapprove the application. However, the department may extend the evaluation period for up to 60 days. Applicants will be given 30 days from the date of receipt of notification by the department in which to file an appeal. (Refer to Section 12505.c, Appeal Procedures.)

x. The issuance of the approval for the proposal with the highest number of points shall be suspended during the 30-day period for filing appeals and during the pendency of any administrative appeal. All administrative appeals shall be consolidated for purposes of the hearing.

xi. Proposals approved under these provisions are bound to the description in the application with regard to type of beds and/or services proposed as well as to the location as defined in the solicitation made by the department. Approval for Medicaid shall be revoked if these aspects of the proposal are altered. Beds to meet a specific disability need approved through this exception must be used to meet the need identified.

e. Private Facility Beds Downsized to Privately Owned Group or Community Homes and State Owned Facility Beds Downsized to State-Owned Group or Community Homes

i. Facilities to whom these provisions apply should contact the regional Office of Citizens with Developmental Disabilities in the region where the proposed community or group home beds will be located. The regional office will review and evaluate the proposals, and recommend approval or disapproval to the Facility Need Review Program.

ii. The Office of Citizens with Developmental Disabilities will send a copy of the application with recommendations and comments to the Facility Need Review Program; the Facility Need Review Program will review the proposal, consider the recommendations, and issue notification to the applicant of approval or disapproval. A copy of the notification will be sent to the Provider Enrollment office in the Health Standards Section. The beds will not be enrolled in Medicaid without the approval of the Facility Need Review Program.

Interested persons may submit written comments to the following address: Thomas D. Collins, Box 91030, Baton Rouge, LA 70821-9030. He is responsible for responding to inquiries regarding this proposed rule. A public hearing on this proposed rule will be held on Tuesday, January 25, 1994

in the Department of Transportation and Development Auditorium, First Floor, 1201 Capitol Access Road, Baton Rouge, LA at 9:30 a.m. All interested persons will be afforded an opportunity to submit data, views or arguments orally or in writing at the public hearing.

Rose V. Forest
Secretary

**FISCAL AND ECONOMIC IMPACT STATEMENT
FOR ADMINISTRATIVE RULES
RULE TITLE: Facility Need Review-
Downsizing ICV/MR Facilities**

- I. ESTIMATED IMPLEMENTATION COSTS (SAVINGS) TO STATE OR LOCAL GOVERNMENTAL UNITS (Summary)
Implementation of this rule is projected to increase state expenditures by \$100 in SFY 1993-94, but no expenditures are expected for SFY 1994-95 and 1995-96.
- II. ESTIMATED EFFECT ON REVENUE COLLECTIONS OF STATE OR LOCAL GOVERNMENTAL UNITS (Summary)
Implementation of this rule will have no effect upon revenue collections of either state or local governmental units.
- III. ESTIMATED COSTS AND/OR ECONOMIC BENEFITS TO DIRECTLY AFFECTED PERSONS OR NON-GOVERNMENTAL GROUPS (Summary)
The proposed rule will ensure a mechanism for development of community home beds determined needed by the department and made available through the downsizing of state-owned residential beds. These beds have previously been determined to meet the criteria of the Facility Need Review Program for purposes of participating in Medicaid. Developmentally disabled persons determined to qualify for placement in these community home beds will benefit from the proposed action, since the action will assure availability of the beds.
- IV. ESTIMATED EFFECT ON COMPETITION AND EMPLOYMENT (Summary)
This proposed rule will have no known impact on competition and employment.

Thomas D. Collins
Director

David W. Hood
Senior Fiscal Analyst

NOTICE OF INTENT

**Department of Health and Hospitals
Office of the Secretary
Bureau of Health Services Financing**

Medicaid Pediatric Immunizations Provisions

The Department of Health and Hospitals, Office of the Secretary, Bureau of Health Services Financing is proposing to adopt the following rule as authorized by R.S. 46:153 and pursuant to Title XIX of the Social Security Act. This proposed rule is in accordance with the provisions of the Administrative Procedure Act, R.S. 49:950 et seq.

The Bureau of Health Services Financing reimburses pediatric immunizations for Medicaid eligible children in

accordance with the regulations governing these services under the Medicaid Program. The Omnibus Budget Reconciliation Act of 1993, (Public Law 103-66) Section 13631 includes a specific prohibition on pediatric immunizations which prohibits the Medicaid payment of a single antigen and its administration if a combined antigen was medically appropriate. This law further stipulates that combined-antigen vaccines must be approved by the secretary of the U. S. Department of Health and Human Services. These provisions are effective October 1, 1993. At this time the only combined antigen which the U. S. Department of Health and Human Services has approved is the measles, mumps and rubella (MMR) combined-antigen vaccine. In order to comply with the Public Law 103-66 and to avoid federal sanctions and penalties the Bureau of Health Services Financing adopted an emergency rule effective October 1, 1993 which was published in the *Louisiana Register*, Volume 10 page 1288. Subsequently, on November 9, 1993 an emergency rule was adopted repealing the October 1, 1993 emergency rule in its entirety and adopting the provisions contained in the following proposed rule. The November 9, 1993 emergency rule appears on pages 1406-1407 of the November 1993 issue of the *Louisiana Register*.

PROPOSED RULE

The Bureau of Health Services Financing providers for a single-antigen vaccine and its administration if a combined-antigen vaccine is medically appropriate and the combined-antigen vaccine is approved by the secretary of the United States Department of Health and Human Services.

Interested persons may submit written comments to the following address: Thomas D. Collins, Office of the Secretary, Bureau of Health Services Financing, Box 91030, Baton Rouge, LA 70821-9030. He is responsible for responding to inquiries regarding this proposed rule. A public hearing will be held on this proposed rule on Tuesday, January 25, 1994 in the auditorium of the Department of Transportation and Development at 1201 Capitol Access Road, Baton Rouge, LA at 9:30 a.m. At that time all interested persons will be afforded an opportunity to submit data, views or arguments orally or in writing at the public hearing.

Copies of this notice and all other Medicaid rules and regulations are available at parish Medicaid offices for review by interested parties.

Rose V. Forrest
Secretary

FISCAL AND ECONOMIC IMPACT STATEMENT FOR ADMINISTRATIVE RULES

RULE TITLE: Medicaid Pediatric Immunizations Provisions

I. ESTIMATED IMPLEMENTATION COSTS (SAVINGS) TO STATE OR LOCAL GOVERNMENTAL UNITS (Summary)

It is estimated that implementation of this proposed rule will increase state expenditures by \$104 for SFY 1994, \$110 for SFY 1995 and \$114 for SFY 1996.

II. ESTIMATED EFFECT ON REVENUE COLLECTIONS OF STATE OR LOCAL GOVERNMENTAL UNITS (Summary)

It is estimated that implementation of this proposed rule will

generate \$289 for SFY 94 and \$296 for SFY 95 and \$306 for SFY 96.

III. ESTIMATED COSTS AND/OR ECONOMIC BENEFITS TO DIRECTLY AFFECTED PERSONS OR NON-GOVERNMENTAL GROUPS (Summary)

There are no economic benefits to children or their families. Physicians who administer the measles, mumps and rubella (MMR) vaccine will be reimbursed the increased federal and state expenditures shown above for the approximately 61 MMR injections to be administered over the next three years.

IV. ESTIMATED EFFECT ON COMPETITION AND EMPLOYMENT (Summary)

There is no estimated effect on competition and employment.

Thomas D. Collins
Acting Director

David W. Hood
Senior Fiscal Analyst

NOTICE OF INTENT

Department of Health and Hospitals Office of the Secretary Bureau of Health Services Financing

Transfers of Assets

The Department of Health and Hospitals, Office of the Secretary, Bureau of Health Services Financing is proposing to adopt the following rule as authorized by R.S. 46:153 and pursuant to Title XIX of the Social Security Act. This proposed rule is in accordance with the provisions of the Administrative Procedure Act, R.S. 49:950 et seq.

The Bureau of Health Services Financing in accordance with Public Law 100-360 adopted a rule governing the transfer of resources under the Medicaid Program on March 20, 1990, which was published in the *Louisiana Register*, Volume 16 Number 3 page 238. This rule requires that transfers of resources shall be in accordance with the Health Care Financing Administration's *State Medicaid Manual*, Section 3250-3255. However the Omnibus Budget Reconciliation Act of 1993, (Public Law 103-66) Section 13611 amended Section 1917(c)(1) (42 U.S.C.1396p(c)(1)) of the Social Security Act, and required changes in how state Medicaid Programs determine periods of restricted ineligibility based on asset transfers for less than fair market value. These changes affect the current definition of "resources," the period of review for transfers and trusts, the penalty period for inappropriate transfers, joint tenancy, applicability of ineligible transfers, and applies to person(s) who establish trusts other than the individual and unallowable trusts. These changes apply to trusts established and assets disposed of on or after the date of enactment of Public Law 103-66 which is August 11, 1993. In order to comply with federal law and to avoid federal sanctions and penalties the Bureau adopted these federally-mandated provisions on October 1, 1993 through an emergency rule. That emergency rule was published in the *Louisiana Register*, Volume 19 Number 10, pages 1290 through 1291.

PROPOSED RULE

The Bureau of Health Services Financing applies the following provisions in determining Medicaid eligibility of institutionalized individuals or applicants for home and community-based services when transfers of resources occur for less than fair market value except for interspousal transfers as mandated by the Omnibus Budget Reconciliation Act of 1993. These changes apply to trusts established and assets disposed of on or after the date of enactment of Public Law 103-66 which is August 11, 1993.

1. The term "resources" is replaced with "assets" thereby extending applicability to income transfers.

2. The bureau determines whether an institutionalized individual (or spouse of such individual) has disposed of assets for less than fair market value during the 36-month period for assets transfers and the 60-month period for certain trusts immediately before he or she made application for Medicaid.

3. The penalty period applicable to individuals who transfer assets for less than fair market value will continue until the total cumulative uncompensated value of assets transferred is depleted in accordance with current program methodology.

4. Penalty period sanctions for multiple or incremental transfers shall be cumulative and follow consecutively rather than concurrently.

5. Assets held in common with another person or persons in a joint tenancy, tenancy in common, or similar arrangement shall be considered transferred by the individual when any action is taken, either by the individual or by any other person, that reduces or eliminates the individual's ownership or control.

6. For purposes of determining an individual's eligibility for Medicaid the following rules shall apply to trusts. An individual shall be considered to have established a trust if assets of the individual were used to form all or part of the corpus of the trust and if any of the following individuals established such trust:

- a. the individual;
- b. the individual's spouse;
- c. a person, including a court or administrative body, with legal authority to act in place of or on behalf of the individual or the individual's spouse;
- d. a person, including any court or administrative body, acting at the direction or upon the request of the individual or the individual's spouse.

The above provisions will be applied without regard to:

- a. the purpose for which a trust is established,
- b. whether the trustees have or exercise any discretion under the trust,
- c. any restrictions on when or whether distribution may be made from the trust, or
- d. any restrictions on the use of distributions from the trust.

In Case of an Irrevocable Trust

a. If there are any circumstances under which payment from the trust could be made to or for the benefit of the individual, the portion of the corpus from which, or the income on the corpus from which, payment to the individual could be made shall be considered as an available resource to the individual.

b. Any portion of the trust from which no payment could be made to the individual under any circumstances shall be considered, as of the date of establishment of the trust to be assets disposed, and subject to transfer of assets sanctions.

The above provisions regulating trusts do not apply to trusts provided that upon the death of such individual the state will receive all amounts remaining in the trust up to an amount equal to the total medical assistance paid on behalf of the individual by Medicaid.

Interested persons may submit written comments to the following address: Thomas D. Collins, Office of the Secretary, Bureau of Health Services Financing, Box 91030, Baton Rouge, LA. He is responsible for responding to inquires regarding this proposed rule. A public hearing will be held on this matter on Tuesday, January 25, 1994 at 9:30 a.m., in the auditorium of the Department of Transportation and Development at 1201 Capitol Access Road, Baton Rouge, LA 70802. At that time all parties will be afforded an opportunity to submit data, views or arguments orally or in writing.

Copies of this proposed rule and all other Medicaid rules and regulations are available at parish Medicaid offices for review by interested parties.

Rose V. Forrest
Secretary

FISCAL AND ECONOMIC IMPACT STATEMENT FOR ADMINISTRATIVE RULES RULE TITLE: Transfer of Assets and Treatment of Trusts

- I. ESTIMATED IMPLEMENTATION COSTS (SAVINGS) TO STATE OR LOCAL GOVERNMENTAL UNITS (Summary)
It is estimated that implementation of this proposed rule will cost \$250 for SFY 1994 but no costs are projected for SFY 1995 and SFY 1996.
- II. ESTIMATED EFFECT ON REVENUE COLLECTIONS OF STATE OR LOCAL GOVERNMENTAL UNITS (Summary)
It is estimated that this proposed rule will increase revenue collections by \$250 for SFY 1995, but no collections are expected for SFY 1995 and SFY 1996.
- III. ESTIMATED COSTS AND/OR ECONOMIC BENEFITS TO DIRECTLY AFFECTED PERSONS OR NON-GOVERNMENTAL GROUPS (Summary)
Individuals who transfer assets for less than fair market value will have to assume payment for nursing facility services or home and community-based services should the need arise.
- IV. ESTIMATED EFFECT ON COMPETITION AND EMPLOYMENT (Summary)
There is no estimated effect on competition and employment.

Thomas D. Collins
Acting Director

David W. Hood
Senior Fiscal Analyst

NOTICE OF INTENT

Department of Health and Hospitals
Office of the Secretary
Bureau of Protective Services

Referral and Investigation Procedures
(LAC 48:I.Chapter 17)

In accordance with R.S. 49:950 et seq., the Administrative Procedure Act, notice is hereby given that the Department of Health and Hospitals (DHH) has initiated rulemaking to enable the department to implement the Protective Services Agency for individuals 18-59 years of age who are mentally and/or physically dysfunctional, living either independently in the community or with a temporarily or permanently responsible caregiver.

The full text of this proposed rule may be viewed in the Emergency Rule Section of this issue of the *Louisiana Register*.

A public hearing will be held at 1:30 p.m., January 27, 1994, in the Department of Transportation and Development Auditorium, 1201 Capitol Access Road, Baton Rouge, LA. All interested persons are invited to submit written comments on the proposed rule. Such comments should be submitted no later than January 21, 1994, at 4:30 p.m., to Carolyn Maggio, Office of the Secretary, Bureau of Research and Development, Box 2870, Baton Rouge, LA 70821-2870.

Rose V. Forrest
Secretary

FISCAL AND ECONOMIC IMPACT STATEMENT FOR ADMINISTRATIVE RULES

RULE TITLE: DHH Community Adult Protective Services Program

I. ESTIMATED IMPLEMENTATION COSTS (SAVINGS) TO
STATE OR LOCAL GOVERNMENTAL UNITS (Summary)

Salaries for 15 positions with associated costs amounting to a total of \$385,549 for FY 93-94, \$638,565 for FY 94-95, and \$663,856 for FY 95-96.

II. ESTIMATED EFFECT ON REVENUE COLLECTIONS OF
STATE OR LOCAL GOVERNMENTAL UNITS (Summary)

There is no estimated effect on revenue collections of state or local governmental units.

III. ESTIMATED COSTS AND/OR ECONOMIC BENEFITS TO
DIRECTLY AFFECTED PERSONS OR NON-
GOVERNMENTAL GROUPS (Summary)

Mentally and physically dysfunctional adults ages 18-59 living in private homes in the community and who are abused, neglected, exploited or extorted would have access to protective services that here-to-fore have been non-existent. This program will serve as a referral source for law enforcement agencies which should balance out any other involvement they will have in the program.

IV. ESTIMATED EFFECT ON COMPETITION AND
EMPLOYMENT (Summary)

There is no estimated effect on competition and employment.

Rose V. Forrest
Secretary

David W. Hood
Senior Fiscal Analyst

NOTICE OF INTENT

Department of Health and Hospitals
Office of the Secretary
Commission on Perinatal Care and
Prevention of Infant Mortality

Obstetrical/Neonatal Levels of Care

As authorized by R.S. 40:2018, and amended by Act 326 of 1992, the Department of Health and Hospitals, Commission on Perinatal Care and Prevention of Infant Mortality, proposes changes to criteria for certification of levels of care designation of medical facilities providing specific obstetrical and neonatal services in Louisiana.

Obstetrical/Neonatal Levels of Care

In devising criteria for certification of medical facilities for delivery of obstetrical and neonatal services, it is acknowledged that the level of professional expertise and the type of physical facilities available in hospitals vary considerably. The availability of appropriate facilities, equipment and personnel is essential for effective management of the obstetrical and neonatal population with the highest risk. In order to define which institutions are capable of rendering care of the high risk obstetric patient or neonate, the following levels of care are established to describe the characteristics of hospitals to render specific obstetrical and neonatal services. The third edition of *Guidelines for Perinatal Care* published by the American Academy of Pediatrics and the American College of Obstetricians and Gynecologists is used as a reference source, and medical facility square footage floor space requirements and staffing are included in that document.

An obstetrical center/neonatal center must qualify in both the neonatal and obstetrical sections in the same level of care for Level II, but may qualify as either Level III or III Regional independently.

A free-standing children's hospital is not required to have a perinatologist on staff or to have an obstetrical center.

The compliance to staffing requirements for Level III Centers will be determined by reviewing historical averages, not on a day-to-day basis.

The only difference in a Level III and Level III Regional Center is the availability of all sub-specialties required in the *Guidelines for Perinatal Care*. A Level III Center is not expected or required to transport any baby to a Level III Regional Center unless the baby requires the care of a sub-specialist not available at the Level III Center.

The perinatal care program at a Level I hospital must be coordinated jointly by the chiefs of the obstetric and pediatric services. In hospitals that do not have separate departments of pediatrics and obstetrics, one physician may be given the responsibility for coordinating perinatal care.

A qualified physician or a certified nurse midwife must attend all deliveries. When certified nurse midwives are involved in patient care, their specific roles should be delineated by departmental rules and regulations. They must be backed-up by a physician capable of performing forceps deliveries and cesarean deliveries.

Anesthesia personnel with credentials to administer obstetric anesthesia must be readily available. At least one person capable of initiating neonatal resuscitation must be present at every delivery. One other person must be available for emergency resuscitation.

Level I

Obstetrical

I. Facility Mission

A. To provide care and supervision for low risk pregnancies.

B. To have in place a triage system for identification, stabilization and referral of high risk maternal and fetal conditions beyond the scope of care of a Level I Center.

C. All obstetric units should espouse that transfer of an infant in utero is superior in outcome to neonatal transport. Arrangements with Level III and/or Level III Regional facilities for transfer of these patients should exist for all Level I Centers.

II. Minimum Levels of Care

A. Detection and care for unanticipated maternal-fetal problems encountered in labor.

B. Ability at all times to perform cesarean delivery within 30 minutes.

C. Immediate availability of blood and fresh frozen plasma for transfusion.

D. Availability of anesthesia, radiology, ultrasound, electronic fetal monitoring (along with personnel skilled in its use) and laboratory on a 24 hour basis.

E. Postpartum care facilities.

F. Resuscitation and stabilization of all inborn neonates.

G. A qualified physician or Certified Nurse Midwife should attend all deliveries.

III. Medical Staff

A member of the medical staff with obstetric privileges should be chief of obstetrics. It is the responsibility of this person to coordinate perinatal services with the chief of pediatrics.

Level II

Obstetrical

I. Facility Mission

A. Performance of all Level I services at a superior level.

B. Management of high risk conditions appropriate for the level of medical, nursing support and technical expertise available.

C. The role of Level II facility is to provide excellent levels of care for most obstetric conditions in its population, but not to accept transports.

D. Conditions which would result in the delivery of an infant weighing less than 1,250 grams or less than 30 weeks gestation should be referred to a center with a full time perinatologist and Level III or III Regional nursery. Arrangements with Level III and/or III Regional facilities for transfer of these patients should exist for all Level II facilities.

II. Minimum Levels of Care

A. Provide all care provided by a Level I facility.

B. Level II facilities should be able to manage maternal complications of a mild to moderate nature that do not

surpass the capabilities of a well-trained board-certified obstetrician/gynecologist.

C. The needed sub-specialty expertise is almost always neonatal and not perinatal although some cases might be appropriate to co-manage with a perinatologist.

D. Ultrasound must be available on labor and delivery twenty four hours a day.

III. Medical Staff

A. A board-certified/eligible obstetrician with special interest and experience in maternal-fetal medicine must be chief of obstetric services. It is the responsibility of this obstetrician to coordinate perinatal services with the neonatologist in charge of the NICU.

B. Anesthesia personnel with credentials to administer obstetric anesthesia should be readily available. Policies regarding the availability of anesthesia for routine and emergency deliveries should be developed.

C. Specialized medical and surgical consultation should be readily available by medical staff members.

D. A board-certified radiologist and a board-certified clinical pathologist must be available 24 hours a day. Specialized medical and surgical consultation must be readily available.

Level III

Obstetrical

I. Facility Mission

A. Performance of all Level I and II services.

B. Provision of comprehensive perinatal care for high risk mothers both admitted and transferred.

C. The services available at Level III Center vary dramatically from those available in a Level II facility. Pregnancies at highest risk should be managed in these facilities. Pregnancies marked by extreme prematurity, need for fetal intervention, significant maternal illness (acute or chronic) should be referred to a Level III or III Regional Center.

D. Obstetric imaging capabilities to perform targeted ultrasound examination in cases of known abnormalities must be available and directed by a maternal fetal medical specialist.

E. Genetic counseling and diagnostics should be provided as a comprehensive service.

F. Research and educational support to practitioners in the community should be provided through organized outreach educational programs.

G. Provide for and coordinate maternal transport with Level I and Level II Center.

H. Arrangements with Level III Regional Center should exist for the transport of mothers or fetuses requiring care unavailable in a Level III facility or that are better coordinated at a Level III Regional Center.

I. Initial evaluation of new high-risk technologies.

II. Minimum Levels of Care

A. Provide care for the most premature labors.

B. Provide care for the most challenging of fetal conditions. Only those conditions requiring a medical team approach not available to the perinatologist in a Level III Center should be transported to a Level III Regional Center.

C. Provide care for the most challenging of maternal conditions. Only those conditions requiring an OB/ICU environment or specialty support unavailable in a Level III hospital should be transported to a Level III Regional Center.

D. 24 hours in-house anesthesia must be available.

III. Medical Staff

A. The director of the maternal-fetal medicine service at a Level III Center must be a board-certified or eligible maternal-fetal medicine specialist or a board-certified obstetrician with special interest and experience in maternal-fetal medicine who will be designated as the director to assure that appropriate care will be provided by the primary attending physician for high risk maternal transports.

B. When there is not a hospital based maternal-fetal medicine specialist, a strong consultative arrangement must exist through a formal transport arrangement with a Level III or Level III Regional Obstetrical Center with a hospital based maternal-fetal medicine specialist.

In addition, the arrangement should also provide for a review of outcomes and case management for all high-risk obstetrical patients for educational purposes.

C. A board-certified anesthesiologist with special training or experience in maternal-fetal anesthesia should be in charge of obstetric anesthesia services at a Level III Center. Personnel with credentials to administer obstetric anesthesia must be in-house 24 hours a day. Personnel with credentials to administer neonatal and pediatric anesthesia should be available as required.

D. Medical and surgical consultation should be readily available and on staff.

Level III Regional

Obstetrical

I. Facility Mission

A. Performance of all Level I, II and III services.

B. The distinguishing requirement for a Level III Regional designation will be a continuing commitment to maintain a depth and breadth of support specialties available in only the most sophisticated of medical centers.

C. Provide for and coordinate maternal and neonatal transport with Level I, Level II and Level III facilities throughout the state.

D. Initial evaluation of new technologies should be a goal of a Level III Regional Center.

E. A Level III Regional Center should be recognized as a center of research, educational and consultative support to the medical community.

II. Minimum Levels of Care

A. The ability to care for both mother and fetus in a comprehensive manner in an area dedicated to the care of the critically ill parturient.

B. An organized team dedicated to the care of the mother and of the fetus both in utero and after delivery shall be maintained. This will consist of but is not limited to specialists in the following areas: maternal-fetal medicine, neonatology, genetics, the pediatric sub-specialties of surgery, cardiology, neurology, neurosurgery, and hematology. Additionally, sub-specialists to provide expertise in the care of the critically ill parturient shall be on staff in the following areas: adult critical care, cardiothoracic surgery, nephrology,

pulmonary medicine, cardiology, endocrinology, urology, neurosurgery, infectious disease and gastroenterology. A nutritionist shall also be available in the care of these patients.

III. Medical Staff

A. The medical staff as outlined in the Level III classification shall be available and shall coordinate care with the sub-specialties as listed above.

B. The director of the perinatal team at the Level III Regional Center must be a board-certified maternal-fetal specialist.

Level I

Neonatal

I. Facility Mission

A. To evaluate the condition of healthy neonates and provide continuing care of these neonates until their discharge in compliance with state regulations regarding eye care and metabolic screening.

B. To stabilize unexpectedly small or sick neonates before transfer to a Level II, Level III, or Level III Regional Center.

C. To maintain consultation and transfer agreements with Level II, Level III and Level III Regional Centers, emphasizing maternal transport when possible.

II. Minimum Levels of Care

A. Resuscitation and stabilization of all inborn neonates.

B. Nursery defined area with limited access and security or rooming-in facilities.

C. Parent-neonate visitation/interaction must be provided.

D. Data collection and retrieval.

Level II

Neonatal

I. Facility Mission

A. Performance of all Level I services.

B. To provide management of small, sick neonates with a moderate degree of illness that are admitted or transferred.

II. Minimum Levels of Care

A. Neonatal ventilatory support, vital signs monitoring, and fluid infusion in defined area of the nursery.

B. Neonates born in a Level II NICU with a birth weight of less than 1,000 grams, must be transferred to a Level III or Level III Regional NICU once they have been stabilized if they require prolonged ventilatory support or have life threatening diseases or surgical complications requiring a higher level of care.

C. Neonates with a birth weight in excess of 1,000 grams who require prolonged ventilation therapy may be cared for in a Level II facility, provided such facility performs a minimum of 72 days of ventilator. A day of ventilator care is defined as any period of time during a 24-hour period.

D. If a Level II NICU performs less than 72 ventilator days per year, it must transfer any neonate requiring prolonged ventilator therapy to a Level III or Level III Regional NICU. Neonates requiring transfer to a Level III or Level III Regional NICU may be returned to a Level II NICU for convalescence.

III. Medical Staff

A board-eligible/board-certified pediatrician with sub-specialty certification in neonatal medicine must be the medical director of the Level II NICU.

Level III

Neonatal

I. Facility Mission

- A. Performance of all Level I and Level II services.
- B. Provision of comprehensive care of high risk neonates of all categories admitted and transferred.
- C. A Level III NICU will have a neonatal transport team and will be involved in organized outreach educational programs.

II. Minimum Levels of Care

A. There should be one neonatologist for every 10 patients in the continuing care, intermediate care, and intensive care areas. There must be one physician or one neonatal nurse practitioner for every five patients who require intensive care. A three-year phase-in period will be allowed in order for the hospital to recruit adequate staff to meet these requirements.

B. Obstetrics and neonatal diagnostic imaging, provided by obstetricians or radiologists who have special interest and competence in maternal and neonatal disease should be available 24 hours a day.

C. A Level III NICU will have with a neonatologist, a neonatal nurse practitioner or a certified transport registered nurse in-house at all times.

III. Medical Staff

A. The medical director of a Level III NICU must be a board-certified pediatrician with sub-specialty certification in neonatal medicine. The following exceptions are recognized:

1. Board-eligible neonatologists must achieve board certification with five years of completion of fellowship training.

2. In existing units consideration will be given to waiving this requirement for neonatologists who are currently medical directors of Level III NICUs. The request must be made in writing to the Commission on the Prevention of Infant Mortality and Perinatal Care. This exception applies only to the individual at the hospital where the medical director position is held. The physician can not relocate to another hospital nor can the hospital replace the medical director for whom the exception was granted and retain the exception.

B. Medical and surgical consultation must be readily available and pediatric sub-specialists may be used in consultation with a transfer agreement with a Level III Regional NICU.

Level III Regional

Neonatal

I. Facility Mission. A Level III Regional NICU must be capable of the following:

- A. Performance of Level III services.
- B. Provide for and coordinate maternal and neonatal transport with Level I, Level II, and Level III NICUs throughout the state.

II. Medical Staff

A. In addition to the medical staff requirements for a Level III facility, a Level III Regional NICU shall have the following clinical services and sub-specialties available to provide consultation and care in a timely manner:

1. pediatric surgery;
2. pediatric cardiology;
3. pediatric neurology;

4. pediatric hematology;
5. genetics;
6. pediatric nephrology;
7. endocrinology;
8. pediatric gastroenterology;
9. pediatric infectious disease;
10. pediatric pulmonary medicine;
11. cardiovascular surgery;
12. neurosurgery;
13. orthopedic surgery;
14. pediatric urologic surgery;
15. pediatric ophthalmology;
16. pediatric ENT surgery;
17. pediatric nutritionist;
18. pediatric PT/OF.

Interested persons may submit written comments to the following address: Vicki L. Romero, Chairperson, Louisiana Commission on Perinatal Care and Prevention of Infant Mortality, Department of Health and Hospitals, Box 1349, Baton Rouge, LA 70821-1349. She is responsible for responding to inquiries regarding this proposed rule.

A public hearing on the proposed rule will be held on Tuesday, January 25, 1994, in the First Floor Auditorium, Department of Transportation and Development, 1201 Capitol Access Road, Baton Rouge, LA 70802, beginning at 2 p.m. All interested persons will be afforded an opportunity to submit data, views or arguments, orally or in writing, at said hearing.

Rose V. Forrest
Secretary

FISCAL AND ECONOMIC IMPACT STATEMENT FOR ADMINISTRATIVE RULES RULE TITLE: Obstetrical/Neonatal Levels of Care

- I. ESTIMATED IMPLEMENTATION COSTS (SAVINGS) TO STATE OR LOCAL GOVERNMENTAL UNITS (Summary)
There are no implementation costs anticipated from the adoption of these rules.
- II. ESTIMATED EFFECT ON REVENUE COLLECTIONS OF STATE OR LOCAL GOVERNMENTAL UNITS (Summary)
The proposed rules will have no effect on revenue collections of state or local governmental units.
- III. ESTIMATED COSTS AND/OR ECONOMIC BENEFITS TO DIRECTLY AFFECTED PERSONS OR NON-GOVERNMENTAL GROUPS (Summary)
The proposed rule may necessitate that the consumer travel a farther distance to receive care, which may add to the consumer's transportation costs.
In addition, the cost impact to provider hospitals may be increased because of the number of neonatal care personnel (neonatologists or neonatal nurse practitioners) required for qualifications of a Level III or a Level III Regional Center.
- IV. ESTIMATED EFFECT ON COMPETITION AND EMPLOYMENT (Summary)
It is not known if this proposed rule will impact competition and employment; however, certain hospitals which had provided a particular service now may not meet the necessary established standards, and this may result in potential gain or loss of

qualified personnel and revenue for the hospital to achieve the higher or lower level of care.

Rose V. Forrest
Secretary

David W. Hood
Senior Fiscal Analyst

NOTICE OF INTENT

Department of Health and Hospitals Office of the Secretary

Informed Consent (LAC 48:I.2315-2323)

As authorized by R.S. 40:1299.40E, as enacted by Act 1093 of 1990 and later amended by Act 962 of 1991 and Act 633 of 1993, the Department of Health and Hospitals, Louisiana Medical Disclosure Panel, is proposing to amend rules by adding §§2315-2323, which require which risks must be disclosed under the Doctrine of Informed Consent to patients undergoing medical treatments or procedures and the Consent Form to be signed by the patient and physician before undergoing any such treatment or procedure. This amends rules adopted in the December 1992 issue of the *Louisiana Register*, pages 1391-1399, by adding §§2315-2323.

Title 48

PUBLIC HEALTH-GENERAL

Part I. General Administration

Chapter 23. Informed Consent

§2315. Cataract Surgery with or without Implantation of Intraocular Lens (placement of lens into eye)

- A. Loss of vision or decrease in vision;
- B. loss of eye;
- C. infection;
- D. bleeding inside or behind the eye;
- E. uncomfortable or painful eye;
- F. continued need for glasses;
- G. less attractive appearance, i.e. droopy eyelid;
- H. need for laser surgery to correct clouding of vision;
- I. need for additional treatment and/or surgery.

AUTHORITY NOTE: Promulgated in accordance with R.S. 40:1299.40E et seq.

HISTORICAL NOTE: Promulgated by the Department of Health and Hospitals, Louisiana Medical Disclosure Panel, LR 20:

§2316. Glaucoma Surgery

- A. Loss of vision or decrease in vision;
- B. loss of eye;
- C. infection;
- D. bleeding inside or behind the eye;
- E. uncomfortable or painful eye;
- F. less attractive eye;
- G. unsuccessful or temporary control of glaucoma or worsening of glaucoma;
- H. cataract formation or progression;
- I. need for additional treatment and/or surgery.

AUTHORITY NOTE: Promulgated in accordance with R.S. 40:1299.40E et seq.

HISTORICAL NOTE: Promulgated by the Department of Health and Hospitals, Louisiana Medical Disclosure Panel, LR 20:

§2317. Corneal Surgery: Corneal Transplant, Pterygium, or Other

- A. Loss of vision or decrease in vision;
- B. loss of eye;
- C. infection;
- D. bleeding inside or behind the eye;
- E. uncomfortable or painful eye;
- F. increased eye pressure;
- G. less attractive eye;
- H. need for additional treatment and/or surgery.

AUTHORITY NOTE: Promulgated in accordance with R.S. 40:1299.40E et seq.

HISTORICAL NOTE: Promulgated by the Department of Health and Hospitals, Louisiana Medical Disclosure Panel, LR 20:

§2318. Laser Capsulotomy (creation of opening in lens membrane)

- A. Loss of vision or decrease in vision;
- B. failure to improve vision;
- C. glaucoma (increased eye pressure);
- D. retinal detachment (separation of nerve layers of eye);
- E. dislocation of lens implant.

AUTHORITY NOTE: Promulgated in accordance with R.S. 40:1299.40E et seq.

HISTORICAL NOTE: Promulgated by the Department of Health and Hospitals, Louisiana Medical Disclosure Panel, LR 20:

§2319. Enucleation or Evisceration (removal of eye or its contents)

- A. Bleeding;
- B. infection;
- C. chronic discomfort or pain;
- D. less attractive appearance;
- E. need for additional treatment and/or surgery.

AUTHORITY NOTE: Promulgated in accordance with R.S. 40:1299, 40E et seq.

HISTORICAL NOTE: Promulgated by the Department of Health and Hospitals, Louisiana Medical Disclosure Panel, LR 20:

§2320. Radial Keratotomy (reshape cornea by multiple cuts)

- A. Loss of vision or decrease in vision;
- B. loss of eye;
- C. infection;
- D. variable vision;
- E. radiating images around lights;
- F. over correction, under correction or distortion of vision;
- G. cataract formation or progression;
- H. retained need for glasses;
- I. inability to wear contact lenses;
- J. glare problems causing loss of ability to drive;
- K. need for additional treatment and/or surgery.

AUTHORITY NOTE: Promulgated in accordance with R.S. 40:1299.40E et seq.

HISTORICAL NOTE: Promulgated by the Department of Health and Hospitals, Louisiana Medical Disclosure Panel, LR 20:

§2321. Eye Muscle Surgery

- A. Loss of vision or decrease in vision;
- B. loss of eye;
- C. double vision;
- D. need for additional eye muscle surgery.

AUTHORITY NOTE: Promulgated in accordance with R.S. 40:1299.40E et seq.

HISTORICAL NOTE: Promulgated by the Department of Health and Hospitals, Louisiana Medical Disclosure Panel, LR 20:

§2322. Laser Treatment of Eye (glaucoma or retina problems)

- A. Loss of vision or decrease in vision;
- B. increase in eye pressure (glaucoma);
- C. visual distortion;
- D. need for surgery inside of the eye;
- E. need for additional repeat laser treatment to correct clouding of vision.

AUTHORITY NOTE: Promulgated in accordance with R.S. 40:1299.40E et seq.

HISTORICAL NOTE: Promulgated by the Department of Health and Hospitals, Louisiana Medical Disclosure Panel, LR 20:

§2323. Retina (nerve layer of eye)/Vitreous (central gel-like substance in eye) Surgery

- A. Loss of vision;
- B. loss of eye;
- C. infection;
- D. bleeding;
- E. uncomfortable or painful eye;
- F. double vision;
- G. cataract formation or progression;
- H. need for additional treatment and/or surgery.

AUTHORITY NOTE: Promulgated in accordance with R.S. 40:1299.40E et seq.

HISTORICAL NOTE: Promulgated by the Department of Health and Hospitals, Louisiana Medical Disclosure Panel, LR 20:

Interested persons may submit written comments by February 1, 1994, to Donald J. Palmisano, M.D., J.D., Chairman, Louisiana Medical Disclosure Panel, Department of Health and Hospitals, Box 1349, Baton Rouge, LA 70821-1349. He is responsible for responding to inquiries regarding this proposed rule.

A public hearing on the proposed rule will be held at 2 p.m., Tuesday, February 1, 1994, in the First Floor Auditorium, Department of Transportation and Development Building, 1201 Capitol Access Road, Baton Rouge, LA 70802. All interested persons will be afforded an opportunity to submit data, views or arguments, orally or in writing, at said hearing.

Rose V. Forrest
Secretary

**FISCAL AND ECONOMIC IMPACT STATEMENT
FOR ADMINISTRATIVE RULES
RULE TITLE: Informed Consent**

- I. ESTIMATED IMPLEMENTATION COSTS (SAVINGS) TO STATE OR LOCAL GOVERNMENTAL UNITS (Summary)
There are no implementation costs anticipated from the adoption of these rules.
- II. ESTIMATED EFFECT ON REVENUE COLLECTIONS OF STATE OR LOCAL GOVERNMENTAL UNITS (Summary)
The proposed rules will have no effect on revenue collections of state or local governmental units.

III. ESTIMATED COSTS AND/OR ECONOMIC BENEFITS TO DIRECTLY AFFECTED PERSONS OR NON-GOVERNMENTAL GROUPS (Summary)

There will be no costs and/or economic benefits to directly affected persons or non-governmental groups.

IV. ESTIMATED EFFECT ON COMPETITION AND EMPLOYMENT (Summary)

There is no effect projected on competition and employment from implementation of these rules.

Rose V. Forrest
Secretary

David W. Hood
Senior Fiscal Analyst

NOTICE OF INTENT

**Department of Health and Hospitals
Medical Disclosure Panel**

Informed Consent (LAC 48:I.2324)

As authorized by R.S. 40:1299.40E, as enacted by Act 1093 of 1990 and later amended by Act 962 of 1991, and Act 633 of 1993, the Department of Health and Hospitals, Medical Disclosure Panel, is proposing to amend rules which require which risks must be disclosed under the Doctrine of Informed Consent to patients undergoing medical treatments or procedures and the Consent Form to be signed by the patient and physician before undergoing any such treatment or procedure. This amends rules adopted in the *Louisiana Register*, pages 1391-1399, December 1992.

TITLE 48

PUBLIC HEALTH—GENERAL

Part I. General Administration

Chapter 23. Informed Consent

§2324. Disclosure of Risks/Patient Consent

Pursuant to R.S. 40:1299.40E, the Louisiana Medical Disclosure Panel recommends use of the following general form, or use of a substantially similar form, for disclosure of risks and hazards related to medical care and surgical procedures.

**PATIENT CONSENT TO MEDICAL TREATMENT
OR SURGICAL PROCEDURE AND ACKNOWLEDGMENT
OF RECEIPT OF MEDICAL INFORMATION**

**INFORMATION ABOUT THIS DOCUMENT
READ CAREFULLY BEFORE SIGNING**

TO THE PATIENT: You have been told that you should consider medical treatment/surgery. Louisiana law requires us to tell you (1) the nature of your condition, (2) the general nature of the medical treatment/surgery, (3) the risks of the proposed treatment/surgery, as defined by the Louisiana Medical Disclosure Panel or as determined by your doctor, and (4) reasonable therapeutic alternatives and material risks associated with such alternatives.

You have the right, as a patient, to be informed about your condition and the recommended surgical, medical or diagnostic procedure to be used so that you may make the decision whether or not to undergo the procedure after knowing the risks and hazards involved.

In keeping with the Louisiana law of informed consent, you are being asked to sign a confirmation that we have discussed all these matters. We have already discussed with you the common problems and risks. We wish to inform you as completely as possible. Please read the form carefully. Ask about anything you do not understand, and we will be pleased to explain it.

1. **Patient Name:** _____

2. **Treatment/Procedure:** _____

(a) Description, nature of the treatment/procedure: _____

(b) Purpose: _____

3. **Patient Condition:**

Patient's diagnosis, description of the nature of the condition or ailment for which the medical treatment, surgical procedure or other therapy described in item number 2 is indicated and recommended:

4. **Material Risks of treatment procedure:**

(a) All medical or surgical treatment involves risks. Listed below are those risks associated with this procedure that we believe a reasonable person in your (the patient's) position would likely consider significant when deciding whether to have or forego the proposed therapy. Please ask your physician if you would like additional information regarding the nature or consequences of these risks, their likelihood of occurrence, or other associated risks that you might consider significant but may not be listed below.

See attachment for risks identified by the Louisiana Medical Disclosure Panel

See attachment for risks determined by your doctor

(b) Additional risks (if any) particular to the patient because of a complicating medical condition are:

(c) Risks generally associated with any surgical treatment/procedure, including anesthesia are: death, brain damage, disfiguring scars, quadriplegia (paralysis from neck down), paraplegia (paralysis from waist down), the loss or loss of function of any organ or limb, infection, bleeding, and pain.

5. **Reasonable therapeutic alternatives and the risks associated with such alternatives are:**

**ACKNOWLEDGMENT
AUTHORIZATION AND CONSENT**

6. (a) **No Guarantees:** All information given me and, in particular, all estimates made as to the likelihood of occurrence of risks of this or alternate procedures or as to the prospects of success, are made in the best professional judgment of my physician. The possibility and nature of complications cannot always be accurately anticipated and, therefore, there is and can be no guarantee, either express or implied, as to the success or other results of the medical treatment or surgical procedure.
- (b) **Additional Information:** Nothing has been said to me, no information has been given to me, and I have not relied upon any information that is inconsistent with the information set forth in this document.
- (c) **Particular Concerns:** I have had an opportunity to disclose to and discuss with the physician providing such information, those risks or other potential consequences of the medical treatment or surgical procedure that are of particular concern to me.
- (d) **Questions:** I have had an opportunity to ask, and I have asked, any questions I may have about the information in this document and any other questions I have about the proposed treatment or procedure, and all such questions were answered in a satisfactory manner.
- (e) **Authorized Physician:** The physician (or physician group) authorized to administer or perform the medical treatment, surgical procedures or other therapy described in item 2 is:

(Name of authorized physician or group)

- (f) **Physician Certification:** I hereby certify that I have provided and explained the information set forth herein, including any attachment, and answered all questions of the patient, or the patient's representative, concerning the medical treatment or surgical procedure, to the best of my knowledge and ability.

(Signature of Physician)

Date

Time

CONSENT

Consent: I hereby authorize and direct the designated authorized physician/group, together with associates and assistants of his choice, to administer or perform the medical treatment or surgical procedure described in item 2 of this Consent Form, including any additional procedures or services as they may deem necessary or reasonable, including the administration of any general or regional anesthetic agent, x-ray or other radiological services, laboratory services, and the disposal of any tissue removed during a diagnostic or surgical procedure, and I hereby consent thereto.

I have read and understand all information set forth in this document and all blanks were filled in prior to my signing. This authorization for and consent to medical treatment or surgical procedure is and shall remain valid until revoked.

I acknowledge that I have had the opportunity to ask any questions about the contemplated medical procedure or surgical procedure described in item 2 of this consent form, including risks and alternatives, and acknowledge that my questions have been answered to my satisfaction.

Witness

Date/Time

Patient or Person Authorized to Consent

Date/Time

If consent is signed by someone other than the patient, state the reason:

Relationship

AUTHORITY NOTE: Promulgated in accordance with R.S. 40:1299, 40E et seq.

HISTORICAL NOTE: Promulgated by the Department of Health and Hospitals, Medical Disclosure Panel, LR 18:1391 (December 1992), LR 20:

Interested persons may submit written comments by February 1, 1994, to Donald J. Palmisano, M.D., J.D., Chairman, Medical Disclosure Panel, Department of Health and Hospitals, Box 1349, Baton Rouge, LA 70821-1349. He is the person responsible for responding to inquiries regarding this proposed rule.

A public hearing on the proposed rule will be held at 2 p.m., Tuesday, February 1, 1994, in the First Floor Auditorium, Department of Transportation and Development Building, 1201 Capitol Access Road, Baton Rouge, LA 70802. All interested persons will be afforded an opportunity to submit data, views or arguments, orally or in writing, at said hearing.

Rose V. Forrest
Secretary

**FISCAL AND ECONOMIC IMPACT STATEMENT
FOR ADMINISTRATIVE RULES
RULE TITLE: Informed Consent (LAC 48:I.2324)**

I. ESTIMATED IMPLEMENTATION COSTS (SAVINGS) TO STATE OR LOCAL GOVERNMENTAL UNITS (Summary)

There are no implementation costs anticipated from the adoption of these rules.

II. ESTIMATED EFFECT ON REVENUE COLLECTIONS OF STATE OR LOCAL GOVERNMENTAL UNITS (Summary)

The proposed rules will have no effect on revenue collections of state or local governmental units.

III. ESTIMATED COSTS AND/OR ECONOMIC BENEFITS TO DIRECTLY AFFECTED PERSONS OR NON-GOVERNMENTAL GROUPS (Summary)

There will be no costs and/or economic benefits to directly affected persons or non-governmental groups.

IV. ESTIMATED EFFECT ON COMPETITION AND EMPLOYMENT (Summary)

There is no effect projected on competition and employment from implementation of these rules.

Rose V. Forrest
Secretary

David W. Hood
Senior Fiscal Analyst

NOTICE OF INTENT

Department of Insurance Commissioner of Insurance

Regulation 49—Billing Audit Guidelines

In accordance with the provisions of R.S. 49:950 et seq. of the Administrative Procedure Act, and Act 664 of the Regular Legislative Session, the Commissioner of Insurance hereby gives notice of his intent to adopt Regulation 49. The regulation provides for the standardization of billing audits for health care services by establishing statewide guidelines.

PROPOSED REGULATION 49

Billing Audit Guidelines

Section 1. Purpose

The purpose of this regulation is to provide for the reasonable standardization of statewide billing audit guidelines for health care providers and payers; and to provide for related matters. These rules are based, at least in part, on the National Health Care Billing Audit Guidelines and variances in order to comply with R.S. 22:10.

Section 2. Authority

This regulation is issued pursuant to the authority vested in the commissioner under the Administrative Procedure Act and R.S. 22:10 of the Insurance Code.

Section 3. Applicability and Scope

This regulation shall apply to health care providers and payers. The provider and/or payer involved in the billing audit shall be responsible for the conduct and results of the billing audit whether conducted by an employee or by contract with another firm. This means that the provider and payer shall:

A. exercise proper supervision of the process to ensure that the audit is conducted according to the spirit of the regulations set forth here;

B. be aware of the actions being undertaken by the auditor in connection with the billing audit and its related activities; and

C. take prompt remedial action if inappropriate behavior by the auditor is discovered.

Section 4. Definitions

For purposes of this regulation:

A. *Ambulatory Surgical Center*—ambulatory surgical center as defined in R.S. 40:2133(A).

B. *Billing Audit*—a process to determine whether data in a provider's medical record documents or supports services listed on a provider's bill. Billing audit does not mean a review of medical necessity of services provided, cost or pricing policy of a facility, and adjustments for "usual and customary".

C. *Health Record which shall mean Medical Record*—any compilation of charts, records, reports, documents, and other memoranda prepared by a health care provider, wherever located, to record or indicate the past or present condition, sickness, or disease, and treatment rendered, physical or mental, of a patient.

D. *Historic Error Rate*—the average error found during all audits conducted by external qualified billing auditors during

the preceding calendar year. It shall be calculated by totaling the net adjustments made to all accounts audited by external qualified billing auditors during that year and dividing that total by the total amount claimed by the audited party to be due on those accounts immediately preceding the audit. This calculation results is an average error rate for all externally audited cases expressed as a percentage.

E. *Hospital*—hospital as defined in R.S. 40:2102(A).

F. *Patient*—a natural person who receives or should have received health care from a health care provider, under a contract, expressed or implied.

G. *Qualified Billing Auditor*—a person employed by a corporation or firm that is recognized as competent to perform or coordinate billing audits and that has explicit policies and procedures protecting the confidentiality of all the patient information in their possession and disposal of this information.

H. *Unbilled Charges*—the volume of services indicated on a bill is less than the volume identified in a provider's health record documentation; also known as undercharges.

I. *Unsupported or Undocumented Charges*—the volume of services indicated on a bill exceeds the total volume identified in a provider's health record documentation; also known as overcharges.

Section 5. Qualifications of Auditors and Audit Coordinators

All persons performing billing audits as well as persons functioning as provider audit coordinators shall have appropriate knowledge, experience, and/or expertise in a number of areas of health care including, but not limited to the following areas:

A. format and content of the health record as well as other forms of medical/clinical documentation;

B. generally accepted auditing principles and practices as they may apply to billing audits;

C. billing claims forms, including the UB-82 and UB 92, the HCFA 1500, and charging and billing procedures;

D. all state and federal regulations concerning the use, disclosure, and confidentiality of all patient records; and

E. specific critical care units, specialty areas, and/or ancillary units involved in a particular audit.

Providers or payers who encounter audit personnel who do not meet these qualifications shall immediately contact the auditor's firm or sponsoring party, but may not request information unrelated to the areas listed above.

Audit personnel shall be able to work with a variety of health care personnel and patients. They shall always conduct themselves in an acceptable, professional manner and adhere to ethical standards, confidentiality requirements, and objectivity. They shall completely document their findings and problems.

All unsupported or unbilled charges identified in the course of an audit must be documented in the audit report by the auditor. Individual audit personnel shall not be placed in a situation through their remuneration, benefits, contingency fees, or other instructions that would call their findings into question. In other words, compensation of audit personnel shall be structured so that it does not create any incentives to produce questionable audit findings. Providers or payers who

encounter an individual who appears to be involved in a conflict of interest shall contact the appropriate management of the sponsoring organization.

Section 6. Notification of Audit

Payers and providers shall make every effort to resolve billing inquiries directly. To support this process, the name and contact telephone number (and/or facsimile number) of each payer or provider representative shall be exchanged no later than the time of billing for a provider and the point of first inquiry by a payer.

If a satisfactory resolution of the questions surrounding the bill is not achieved by payer and provider representatives, then a full audit process may be initiated by the payer.

Generally, billing audits require documentation from or review of a patient's health record and other similar medical/clinical documentation. Health records exist primarily to ensure continuity of care for a patient; therefore, the use of a patient's record for an audit must be secondary to its use in patient care.

To alleviate the potential conflict with clinical uses of the health record and to reduce the cost of conducting a necessary audit, all payer billing audits shall begin with a notification to the provider of an intent to audit. Notification of the provider by the qualified billing auditor shall occur no later than four months following receipt of the final bill by the payer. Once notified, the provider shall respond to the qualified billing auditor within one month with a schedule for the conduct of the audit. The qualified billing auditor shall complete the audit within six months of receipt of the final bill by the payer. When there is a substantial and continuing relationship between a payer and a provider, this relationship may warrant a notification, response, and audit schedule other than that outlined herein. Also, each party shall make reasonable provisions to accommodate circumstances in which the schedule specified herein cannot be met by the other party.

All billing audits shall be conducted "on site".

All requests, whether telephonically or written, for billing audits shall include the following information:

A. the basis of the payer's intent to conduct an audit on a particular bill or group of bills (when the intent is to audit only specific charges or portions of the bill(s) this information should be included in the notification request);

B. name of the patient;

C. admit and discharge dates;

D. name of the auditor and the name of the audit firm;

E. patient account number; and

F. whom to contact at the payer institution and, if applicable, at the agent institution to discuss this request and schedule the audit.

Providers who cannot accommodate an audit request that conforms with these guidelines shall explain why the request cannot be met by the provider in a reasonable period of time. Auditors shall group audits to increase efficiency whenever possible.

If a provider believes an auditor will have problems accessing records, the provider shall notify the auditor prior to the scheduled date of audit. Providers shall supply the auditor/payer with any information that could affect the efficiency of the audit once the auditor is on-site.

Section 7. Provider Audit Coordinators

Providers shall designate an individual to coordinate all billing audit activities. An audit coordinator shall have the same qualifications as an auditor. (See Section 5., Qualifications of Auditors and Audit Coordinators.) Duties of an audit coordinator include, but are not limited to, the coordination of the following areas:

- A. scheduling an audit;
- B. advising other provider personnel/departments of a pending audit;
- C. ensure that the condition of admission is part of the medical record;
- D. verifying that the auditor is an authorized representative of the payer;
- E. gathering the necessary documents for the audit;
- F. coordinating auditor requests for information, space in which to conduct an audit, and access to records and provider personnel;
- G. orienting auditors to hospital audit procedures, record documentation conventions, and billing practices;
- H. acting as a liaison between the auditor and other hospital personnel;
- I. conducting an exit interview with the auditor to answer questions and review audit findings;
- J. reviewing the auditor's final written report and following up on any charges still in dispute;
- K. arranging for payment as applicable; and
- L. arranging for any required adjustment to bills or refunds.

Section 8. Conditions and Scheduling of Audits

In order to have a fair, efficient, and effective audit process, providers and payer auditors shall adhere to the following requirements:

- A. whatever the original intended purpose of the billing audit, all parties shall agree to recognize, record or present any identified unsupported or unbilled charges discovered by the audit parties;
- B. late billing shall not be precluded by the scheduling of an audit;
- C. the parties involved in the audit shall mutually agree to set and adhere to a predetermined time-frame for the resolution of any discrepancies, questions, or errors that surface in the audit;
- D. an exit conference and a written report shall be part of each audit; if the provider waives the exit conference, the auditor shall note that action in the written report. The specific content of the final report shall be restricted to those parties involved in the audit;
- E. if the provider decides to contest the findings, the auditor shall be informed immediately;
- F. once both parties agree to the audit findings, audit results are final;
- G. all personnel involved shall maintain a professional courteous manner and resolve all misunderstandings amicably; and
- H. at times, the audit will note ongoing problems either with the billing or documentation process. When this situation occurs, and it cannot be corrected as part of the exit process, the management of the provider or payer organization shall be

contacted to identify the situation and take appropriate steps to resolve the identified problem. Parties to an audit shall eliminate on-going problems or questions whenever possible as part of the audit process.

Section 9. Confidentiality and Authorizations

The release of medical records requires authorization from the patient. Such authorization shall be provided for in the condition of admission or equivalent statement procured by the hospital or ambulatory surgical center upon admission of the patient. If no such statement is obtained, an authorization for a billing audit shall be required. Authorization need not be specific to the insurer or auditor conducting the audit.

Such authorization shall be obtained by the billing audit firm or payer and shall include:

- A. the name of the payer and, if applicable, the name of the audit firm that is to receive the information;
- B. the name of the institution that is to release the information;
- C. the full name of the patient whose records are to be released;
- D. the extent or nature of the information to be released, with inclusive dates of treatment; and
- E. the signature of the patient or his legal representative and the date the consent is signed.

A patient's assignment of benefits shall include a presumption of authorization to review records.

The audit coordinator or medical records representative shall confirm for the audit representative that a condition of admission statement is available for the particular audit that needs scheduling.

The provider will inform the requestor, on a timely basis, if there are any federal or state laws prohibiting or restricting review of the medical record and if there are institutional confidentiality policies and procedure affecting the review. These institutional confidentiality policies shall not be specifically oriented in order to delay an external audit.

Section 10. Documentation

Verification of charges will include the investigation of whether or not:

- A. charges are reported on the bill accurately;
- B. services are documented in health or other appropriate records as having been rendered to the patient; and
- C. services were delivered by the institution in compliance with the physician's plan of treatment (In appropriate situations, professional staff may provide supplies or follow procedures that are in accordance with established institutional policies, procedures, or professional licensure standards. Many procedures include items that are not specifically documented in a record but are referenced in medical or clinical policies. All such policies should be reviewed, approved, and documented as required by the Joint Commission on Accreditation of Healthcare Organizations or other accreditation of Healthcare Organizations or other accreditation agencies. Policies should be available for review by the auditor.)

The health record documents clinical data on diagnoses, treatments, and outcomes. It was not designed to be a billing document. A patient health record generally documents pertinent information related to care. The health record may

not back up each individual charge on the patient bill. Other signed documentation for services provided to the patient may exist within the provider's ancillary departments in the form of department treatment logs, daily records, individual service/order tickets, and other documents.

Auditors may have to review a number of other documents to determine valid charges. Auditors must recognize that these sources of information are accepted as reasonable evidence that the services ordered by the physician were actually provided to the patient. Providers must ensure that proper policies and procedures exist to specify what documentation and authorization must be in the health record and in the ancillary records and/or logs. These procedures document that services have been properly ordered for and delivered to patients. When sources other than the health record are providing such documentation, the provider shall notify the auditor and make those sources available to the auditor.

Section 11. Fees and Payments

Payment of a bill shall be made promptly and shall not be delayed by an audit process. Payment on a submitted bill from a third-party payer shall be based on amounts billed and covered by the patient's benefit plan.

Billing audits shall be made in accordance with one of the following three audit fee and payment schedules:

A. a \$100 audit fee shall be paid by the auditor to the audited party. Such audited party shall not require payment greater than 100 percent of the audited party's submitted bill minus such party's historic error rate;

B. in those instances where the audited party has had less than 12 audits in a calendar year, the error rate shall be set by mutual agreement between the audited party and the qualified billing auditor; and when the parties cannot agree, then the historic error rate shall be presumed to be seven percent; and

C. the \$100 fee shall be waived in the following scenarios:

1. payment of 100 percent of the covered benefit plan has been made; or

2. the on-site audit commencement date exceeds 60 days from the date of the request for audit; or

3. audit fees are not required or are otherwise being waived.

Each provider's billing audit coordinator shall maintain a log containing the results of all audits performed by external qualified billing auditors in the preceding 24 months. In cases where the log is not complete for the past 24 months, the error rate shall be set by mutual agreement between the audited party and the qualified billing auditor; and when the parties cannot agree, then the historic error rate shall be presumed to be seven percent.

The audit log shall contain the amount billed immediately preceding the audit, and net adjustment resulting from the audit, the name, address, and phone number of the audit firm conducting the audit, and the name of the qualified billing auditor who performed the audit. Audits whose results are in dispute and audits ordered by the provider and conducted by its own or contracted audit organization shall not be included in the audit log. The audit log shall be available at all times during regular business hours for inspection by any qualified billing auditor.

Audit fees, if needed, are to be paid upon commencement of the on-site billing audit. Any payment identified in the audit results, that is owed to either party by the other, shall be settled by the audit parties within a reasonable period of time — not to exceed 30 days after completion of the audit unless the two parties agree otherwise.

Neither the provider nor the qualified billing auditor shall require a billing, or re-billing, or refund request following final audit determination, but all findings shall be netted and the final result will be due by the relevant party without additional billing.

Photocopying and duplication charges shall be paid in accordance with R.S. 40:1299.96.

These proposed regulation are scheduled to become effective March 20, 1994.

Interested parties may submit written comments on the proposed regulation until 4:30 p.m., January 18, 1994 to: C. Noël Wertz, Senior Attorney, Box 94214, Baton Rouge, LA 70804-9214.

James H. "Jim" Brown
Commissioner

FISCAL AND ECONOMIC IMPACT STATEMENT FOR ADMINISTRATIVE RULES RULE TITLE: Regulation 49

I. ESTIMATED IMPLEMENTATION COSTS (SAVINGS) TO STATE OR LOCAL GOVERNMENTAL UNITS (Summary)

It is not anticipated that the Department of Insurance will incur any costs or savings as a result of implementing this regulation. The regulation does not impose any new duties on the department.

II. ESTIMATED EFFECT ON REVENUE COLLECTIONS OF STATE OR LOCAL GOVERNMENTAL UNITS (Summary)

Adoption of this regulation will not have any effect on revenue collections by the state or local governmental units. There are no fees, fines or other revenue generating activities imposed.

III. ESTIMATED COSTS AND/OR ECONOMIC BENEFITS TO DIRECTLY AFFECTED PERSONS OR NON-GOVERNMENTAL GROUPS (Summary)

It is not anticipated that this regulation will impose any additional costs on the health care providers and insureds.

IV. ESTIMATED EFFECT ON COMPETITION AND EMPLOYMENT (Summary)

It is not anticipated that there will be any effect on either competition or employment resulting from the adoption of this regulation.

Brenda St. Romain
Assistant Commissioner

David W. Hood
Senior Fiscal Analyst

NOTICE OF INTENT

Department of Insurance
Commissioner of Insurance

Regulation 51—Individual Health Insurance Rating Requirements

In accordance with the provisions of R.S. 49:950 et seq. of the Administrative Procedure Act, and Act 655 of the 1993 Regular Legislative Session, the commissioner of insurance hereby gives notice of his intent to adopt Regulation 51. This regulation implements a modified community rating system to be followed by carriers marketing individual health and accident insurance policies. It defines key terms and imposes restrictions on ratemaking activities. It also establishes a methodology for determining rates increases.

The text of this proposed rule may be viewed in its entirety in the emergency rule section of this issue of the *Louisiana Register*.

The proposed regulation is scheduled to become effective March 20, 1994.

Interested parties may submit comments on the proposed regulation until 4:30 p.m., January 14, 1994 to: C. Noël Wertz, Senior Attorney, Box 94214, Baton Rouge, LA 70804-9214.

James H. "Jim" Brown
Commissioner of Insurance

FISCAL AND ECONOMIC IMPACT STATEMENT FOR ADMINISTRATIVE RULES RULE TITLE: Regulation 51-Individual Health Insurance Rating Requirements

- I. ESTIMATED IMPLEMENTATION COSTS (SAVINGS) TO STATE OR LOCAL GOVERNMENTAL UNITS (Summary)
It is not anticipated that the Department of Insurance will incur any costs or savings as a result of implementing this regulation. The regulation does not impose any new duties on the department.
- II. ESTIMATED EFFECT ON REVENUE COLLECTIONS OF STATE OR LOCAL GOVERNMENTAL UNITS (Summary)
Adoption of this regulation will not have any effect on revenue collections by the state or local governmental units. There are no fees, fines or other revenue generating activities imposed.
- III. ESTIMATED COSTS AND/OR ECONOMIC BENEFITS TO DIRECTLY AFFECTED PERSONS OR NON-GOVERNMENTAL GROUPS (Summary)
There is not sufficient data available at the present time to determine if there could be any costs and/or economic benefits to the health care insurers or the insureds.
- IV. ESTIMATED EFFECT ON COMPETITION AND EMPLOYMENT (Summary)
It is not anticipated that there will be any effect on either competition or employment resulting from the adoption of this regulation.

Brenda St. Romain
Assistant Commissioner

David W. Hood
Senior Fiscal Analyst

NOTICE OF INTENT

Department of Insurance
Commissioner of Insurance

Regulation 52—Small Group Health Insurance Rating Requirements

In accordance with the provisions of R.S. 49:950 et seq. of the Administrative Procedure Act, and Act 655 of the 1993 Regular Legislative Session, the Commissioner of Insurance hereby gives notice of his intent to adopt Regulation 52. The regulation implements a modified community rating system for small group health insurance carriers, defines key terms and imposes restrictions on ratemaking activities. It also establishes a methodology for determining rate increases.

The text of this proposed rule may be viewed in its entirety in the emergency rule section of this issue of the *Louisiana Register*.

The regulation is scheduled to become effective on March 20, 1994.

Interested parties may submit comments on the proposed regulation until 4:30 p.m., January 14, 1994 to: C. Noël Wertz, Senior Attorney, Box 94214, Baton Rouge, LA 70804-9214.

James H. "Jim" Brown
Commissioner of Insurance

FISCAL AND ECONOMIC IMPACT STATEMENT FOR ADMINISTRATIVE RULES RULE TITLE: Reg 52—Small Group Health Insurance Rating Requirements

- I. ESTIMATED IMPLEMENTATION COSTS (SAVINGS) TO STATE OR LOCAL GOVERNMENTAL UNITS (Summary)
It is not anticipated that the Department of Insurance will incur any costs or savings as a result of implementing this regulation. The regulation does not impose any new duties on the department.
- II. ESTIMATED EFFECT ON REVENUE COLLECTIONS OF STATE OR LOCAL GOVERNMENTAL UNITS (Summary)
Adoption of this regulation will not have any effect on revenue collections by the state or local governmental units. There are no fees, fines or other revenue generating activities imposed.
- III. ESTIMATED COSTS AND/OR ECONOMIC BENEFITS TO DIRECTLY AFFECTED PERSONS OR NON-GOVERNMENTAL GROUPS (Summary)
There is not sufficient data available at the present time to determine if there could be any costs and/or economic benefits to the health care insurers or the insureds.
- IV. ESTIMATED EFFECT ON COMPETITION AND EMPLOYMENT (Summary)
It is not anticipated that there will be any effect on either competition or employment resulting from the adoption of this regulation.

Brenda St. Romain
Assistant Commissioner

David W. Hood
Senior Fiscal Analyst

NOTICE OF INTENT

**Department of Public Safety and Corrections
Office of State Police**

Charitable Bingo, Keno, Raffle
(LAC 42:I.Chapters 17, 19, and 22)

The Department of Public Safety and Corrections, Office of State Police, in accordance with R.S. 36:408, R.S. 40:1485.4 and R.S. 49:950 et seq., gives notice that rulemaking procedures have been instituted to amend certain sections of Chapter 17, 19, and 22 and to adopt LAC 42:I.1789.

The text of this proposed rule may be viewed in its entirety at the Office of State Police, Box 66614, Baton Rouge, LA 70896 or by calling (504) 925-1835 and in the Office of the State Register, Box 94095, Baton Rouge, LA 70804-9095.

Interested persons may submit written comments on the proposed rule to: Lieutenant Joseph T. Booth, Director, Division of Charitable Gaming Control, Office of State Police, Louisiana Department of Public Safety and Corrections, Box 66614, Baton Rouge, LA 70896.

Paul W. Fontenot
Superintendent

**FISCAL AND ECONOMIC IMPACT STATEMENT
FOR ADMINISTRATIVE RULES
RULE TITLE: Charitable Gaming**

I. ESTIMATED IMPLEMENTATION COSTS (SAVINGS) TO STATE OR LOCAL GOVERNMENTAL UNITS (Summary)

The total cost incurred by the state for implementation of the proposed rule is \$2,439.36. It will have no impact on local governmental units.

II. ESTIMATED EFFECT ON REVENUE COLLECTIONS OF STATE OR LOCAL GOVERNMENTAL UNITS (Summary)

The proposed rules will increase the states revenues by a total of \$168,000 annually.

III. ESTIMATED COSTS AND/OR ECONOMIC BENEFITS TO DIRECTLY AFFECTED PERSONS OR NON-GOVERNMENTAL GROUPS (Summary)

There will be an estimated minimum one time cost of \$752.95 to non-commercial lessors, an estimated minimum one time cost of \$1,102.95 to commercial lessors, and an estimated cost to electronic video bingo distributors to pay a representative an average of \$374 per week for each location where the distributor has machines.

IV. ESTIMATED EFFECT ON COMPETITION AND EMPLOYMENT (Summary)

There should not be an increased amount of competition between the licensees themselves. The proposed action will result in increased employment of electronic video bingo representatives at bingo halls.

Rex McDonald
Undersecretary

John R. Rombach
Legislative Fiscal Officer

NOTICE OF INTENT

**Department of Revenue and Taxation
Sales Tax Division**

Automobile Rentals; Allocation of Use Tax
(LAC 61:I.4307)

As authorized by R.S. 47:303(B)(6) and in accordance with R.S. 49:950 et seq., the Administrative Procedure Act, notice is given that the Department of Revenue and Taxation proposes to amend LAC 61:I:4307 to provide for the allocation of the local sales and use taxes paid on automobiles purchased for lease or rental to each automobile rental contract.

Act 569 of the 1993 Regular Session of the Louisiana Legislature requires the department to promulgate rules to provide for an allocation schedule that will ensure an equitable allocation that is not in excess of the actual local sales taxes paid by the lessors and renters.

The full text of this proposed rule is published in the Emergency Rule Section of this issue of the *Louisiana Register*.

All interested persons may submit data, views, or arguments, in writing to Raymond Tangney, Director of the Sales Tax Division, Department of Revenue and Taxation, Box 201, Baton Rouge, LA 70821. All comments must be submitted by 4:30 p.m., Thursday, January 27, 1994. A public hearing will be held on Friday, January 28, 1994 at 10 a.m. in the Department of Revenue and Taxation secretary's conference room, 330 North Ardenwood Drive, Baton Rouge, LA.

Ralph Slaughter
Secretary

**FISCAL AND ECONOMIC IMPACT STATEMENT
FOR ADMINISTRATIVE RULES
RULE TITLE: Automobile Rentals;
Use Tax Allocation**

I. ESTIMATED IMPLEMENTATION COSTS (SAVINGS) TO STATE OR LOCAL GOVERNMENTAL UNITS (Summary)

The department will incur photocopying and mailing costs to provide information about this rule to approximately 120 affected dealers. This will be done with existing resources with no additional appropriation.

II. ESTIMATED EFFECT ON REVENUE COLLECTIONS OF STATE OR LOCAL GOVERNMENTAL UNITS (Summary)

The proposed regulations will have no effect on revenue collections of state or local governmental units.

III. ESTIMATED COSTS AND/OR ECONOMIC BENEFITS TO DIRECTLY AFFECTED PERSONS OR NON-GOVERNMENTAL GROUPS (Summary)

The rental car industry subject to R.S. 47:551 will benefit economically by being able to recoup the local sales tax paid on rental vehicles. Persons who lease automobiles on a short-term basis will incur additional costs of \$2 per day.

IV. ESTIMATED EFFECT ON COMPETITION AND EMPLOYMENT (Summary)

At the beginning of a fiscal year there should be no effect on competition among auto dealers who elect to avail themselves of this use tax recovery; however, as larger firms recoup this tax they may cease collection of the "fee" while smaller firms continue to collect it putting them at a disadvantage. Also, a firm may elect not to collect it on larger customers, which will be unfair to the individual customers. The proposed recovery fee is \$2 per day on vehicles rented 29 days or less.

Ralph Slaughter
Secretary

David W. Hood
Senior Fiscal Analyst

NOTICE OF INTENT

Department of Social Services Office of Rehabilitation Services

Policy Manual (LAC 67:VII.101)

In accordance with the provisions of R.S. 49:950 et seq., the Administrative Procedure Act, the Department of Social Services, Louisiana Rehabilitation Services (LRS) is revising its policy manual.

The purpose of this proposed rule is to provide federally mandated revisions to the rules governing the policy used by LRS in implementing its various programs.

This proposed rule supersedes all rules previously promulgated regarding the LRS policy manual.

Title 67

SOCIAL SERVICES

Part VII. Louisiana Rehabilitation Services

Chapter 1. General Provisions

§101. Policy Manual

A. LRS Policy Manual, fiscal year 1994, provides opportunities for employment outcomes and independence to individuals with disabilities through vocational and other rehabilitation services. Its policy manual guides its functions and governs its actions within the parameters of federal law.

B. Copies of the policy manual can be obtained at Louisiana Rehabilitation Services headquarters, 8225 Florida Boulevard, Baton Rouge, LA, at each of its nine regional offices, and at the Office of the State Register, 1051 North Third Street, Baton Rouge, LA.

AUTHORITY NOTE: Promulgated in accordance with R.S. 49:664.6 and R.S. 36:477.

HISTORICAL NOTE: Promulgated by the Department of Social Services, Louisiana Rehabilitation Services, LR 17:891 (September 1991), amended LR 20:

Public hearings beginning at 10 a.m. will be held on January 27, 1994, in all LRS Regional Offices. The hearing locations are as follows: Baton Rouge at 2087 Beaumont Drive; New Orleans at 2026 St. Charles Avenue; Shreveport at 1525 Fairfield Avenue; Monroe at 122 St. John Street; Alexandria at 900 Murray Street; Houma at 101 Glynn Avenue; Lafayette at 825 Kaliste Saloom Road, Building VI, Suite 350; Hammond at West Park Professional Building, 1200 Derek Drive, Suite 200; Lake Charles at 4016 Avenue

F. All interested persons will be afforded an opportunity to express issues, views or concerns at the hearings. Written commentary will be accepted by Louisiana Rehabilitation Services through February 11, 1994 and should be addressed to: May Nelson, Director, Louisiana Rehabilitation Services, Box 94371, Baton Rouge, LA 70804-9371.

Gloria Bryant-Banks
Secretary

FISCAL AND ECONOMIC IMPACT STATEMENT FOR ADMINISTRATIVE RULES RULE TITLE: Policy Manual (LAC 67:VII.101)

- I. ESTIMATED IMPLEMENTATION COSTS (SAVINGS) TO STATE OR LOCAL GOVERNMENTAL UNITS (Summary)
There is no anticipated implementation costs or savings.
- II. ESTIMATED EFFECT ON REVENUE COLLECTIONS OF STATE OR LOCAL GOVERNMENTAL UNITS (Summary)
Louisiana Rehabilitation Services has sufficient funds to provide rehabilitation services to the severely disabled and administer the program as Act 14 was approved by the Louisiana Legislature.
- III. ESTIMATED COSTS AND/OR ECONOMIC BENEFITS TO DIRECTLY AFFECTED PERSONS OR NON-GOVERNMENTAL GROUPS (Summary)
Louisiana Rehabilitation Services has sufficient funds to provide services to severely disabled individuals in Selection Group 1. Individuals in Selection Group 2 and 3 will not be provided planned costs services unless funds are determined to be available as has been the case since March, 1988.
- IV. ESTIMATED EFFECT ON COMPETITION AND EMPLOYMENT (Summary)
There is no proposed change in competition and employment in the public and private sectors.

May Nelson
Director

David W. Hood
Senior Fiscal Analyst

NOTICE OF INTENT

Department of Transportation and Development Utility and Permit Section

Standards Manual - Facilities in Right-of-Way (LAC 70:III.Chapter 13)

In accordance with the applicable provisions of the Administrative Procedure Act, R.S. 49:950 et seq., notice is hereby given that the Department of Transportation and Development intends to adopt a rule entitled "Standards Manual for Accommodating Utilities, Driveways and Other Facilities on Highway Right-of-Way" in accordance with R.S. 19:14, 30:210-217, 32:236, 38:2223, 38:3094, 48:191-193, 48:217, 48:295.1, 48:295.2, 48:295.3, 48:295.4, 48:343, 48:344, 48:381-383, 48:385-387, 51:1901-1909, 51:1909.1.

The full text of this proposed rule may be obtained from the Office of the State Register, 1051 North Third Street, Baton

Rouge, LA 70804, telephone (504) 342-5015, or from the Department of Transportation and Development, Utility and Permit Section, Fifth Floor, 1201 Capitol Access Road, Baton Rouge, LA 70804.

All interested persons so desiring shall submit oral or written data, views, comments or arguments no later than 30 days from the date of publication of this notice of intent to: John Collins, Utility and Permit Section, Department of Transportation and Development, Box 94245, Baton Rouge, LA 70804-9245; telephone (504) 379-1509.

Jude W. P. Patin
Secretary

**FISCAL AND ECONOMIC IMPACT STATEMENT
FOR ADMINISTRATIVE RULES
RULE TITLE: Standards Manual for
Accommodating Utilities, Driveways
and Other Facilities on Highway Right-of-Way**

I. ESTIMATED IMPLEMENTATION COSTS (SAVINGS) TO STATE OR LOCAL GOVERNMENTAL UNITS (Summary)

Approximately \$18,700,000 (amount varies by 15 percent from year to year) is spent each year for this program. Since this policy has been in place for several decades, there will be no implementation costs to the Department of Transportation and Development or any other governmental units.

II. ESTIMATED EFFECT ON REVENUE COLLECTIONS OF STATE OR LOCAL GOVERNMENTAL UNITS (Summary)

There will be no effect on revenue collections of state or local governmental units.

III. ESTIMATED COSTS AND/OR ECONOMIC BENEFITS TO DIRECTLY AFFECTED PERSONS OR NON-GOVERNMENTAL GROUPS (Summary)

This program costs utility owners approximately \$40,000,000 to \$65,000,000 each year in utility relocation and processing expenses, and saves them several billion dollars each year in right-of-way and servitude expenses. There will be no change in costs or benefits to persons or non-governmental groups. These policies are in effect at the present time. This rule formally assembles these policies in a manual.

IV. ESTIMATED EFFECT ON COMPETITION AND EMPLOYMENT (Summary)

There will be no effect on competition or employment.

Jude W. P. Patin
Secretary

David W. Hood
Senior Fiscal Analyst

NOTICE OF INTENT

**Department of Treasury
Bond Commission**

**Disclosure of Agreements between Financial
Professionals for Negotiated Transactions**

In accordance with the provisions of the Administrative Procedure Act, R.S. 49:950 et seq., notice is hereby given that the Bond Commission intends to amend the commission's rules as originally adopted November 20, 1976.

The duties of the Bond Commission (the "commission") require that it choose financial professionals (including, without limitation, firms of underwriters, financial advisors and bond attorneys) in connection with certain bond issues and the commission predicates such choices upon the competing firms' experience, qualifications and performance, in order that a broad spectrum of firms including minority and women-owned and regional firms are given an opportunity to actively and fully participate in such financings.

The commission's duties also require that it approve applications from local governmental entities to issue bonds and such applications include information on the financial professionals involved in handling the issues.

In order to insure the integrity of the structure of the financing team which the commission is charged with the responsibility of choosing and/or approving for handling bond issues, the commission hereby proposes to amend the following rule regarding agreements by and between such financial professionals as to the sale of such bonds.

1. Terms and/or existence of all joint accounts and/or any other fee-splitting arrangements by and between financial professionals must be disclosed and approved by the commission.

2. For bond issues for which the commission is charged with the responsibility to choose the financial professionals, the following will apply.

a. Firms under consideration for selection by the commission must file a disclosure statement to be submitted as part of their proposal (whether such proposal is solicited or unsolicited), listing any and all agreements by and between themselves and any other financial professionals which relate to the bond issue.

b. Financial professionals must include, in any proposal submitted to the commission, the name or names of any person or firm, including attorneys, lobbyist and public relations professionals engaged to promote the selection of the particular financial entity.

c. Joint proposals from financial professionals will be allowed only if the commission's solicitation for offers requests and/or permits joint proposals. The commission reserves the right, in its sole discretion, to decide on an issue-by-issue basis whether joint proposals will be permitted.

d. All financial professionals submitting joint proposals and/or intending to enter into joint accounts or any fee-splitting arrangements in connection with a bond issue must fully disclose and have approved by the commission any plan or arrangement to share tasks, responsibilities, and fees

earned, and disclose the financing professionals with whom this sharing is proposed, and any changes thereto which may occur.

e. The Agreement Among Underwriters will govern all transactions during the underwriting period and such agreement must be disclosed and filed with the commission.

f. No later than 45 days following the bond sale, all participating underwriters must file with the commission in notarized affidavit form individual post-sale reports which include a full accounting for all bonds sold and all commissions earned, and any other compensation paid or earned in connection with such sale.

3. Failure to comply with any of the provisions of Section 1 or 2 of this rule may result in a firm's immediate dismissal, disqualification from later issues, or other penalties as may be provided by law or the rules, policies and procedures of the commission as the commission, in its sole discretion, may deem appropriate.

4. For those bond issues which the commission must approve but for which the commission is not responsible for the choice of the financial professionals, the following will apply.

a. The details of any arrangements for compensation of all the financial professionals in the transaction (including any joint accounts or fee-splitting agreements) and the method used to calculate the fees to be earned must be provided to the commission in the written application. The commission's receipt of this information is a prerequisite for being placed on the agenda.

b. At closing, this information must be certified in notarized affidavit form by the financial professional to be correct and filed with the State Bond Commission within five days thereof. This information will form a part of the public record of the bond issue.

Interested persons may submit their views and opinions through January 20, 1994, to Rae Logan, Secretary and Director of the State Bond Commission, twenty-first floor, State Capitol Building, Box 44154, Baton Rouge, LA 70804.

At least eight working days prior to the meeting of the commission at which a rule or rules are proposed to be adopted, amended or repealed, notice of any intention to make an oral presentation shall be given to the director of the commission. If the presentation is to be oral, such notice shall contain the name or names, telephone numbers, and mailing addresses of the person or persons who will make such oral presentation, who they are representing, the estimated time needed for the presentation, and a brief summary of the presentation. Notice of such oral presentation may be sent to all commission members prior to the meeting. If the presentation is to be written, such notice shall contain the name or names of the persons submitting such written statement, who they are representing, and a copy of the statement itself. Such written statement shall be sent to all commission members prior to the meeting. The commission shall consider all written and oral submissions concerning the proposed rules. Upon adoption of a rule, the commission, if requested to do so by an interested person either prior to the

adoption or within 30 days thereafter, shall issue a concise statement of the principal reasons for or against its adoption.

Mary L. Landrieu
Treasurer

**FISCAL AND ECONOMIC IMPACT STATEMENT
FOR ADMINISTRATIVE RULES**

**RULE TITLE: Disclosure of Agreements Between
Financial Professionals for
Negotiated Transactions**

- I. ESTIMATED IMPLEMENTATION COSTS (SAVINGS) TO STATE OR LOCAL GOVERNMENTAL UNITS (Summary)
Revenue impact is neutral. Information required to be provided by the rule is furnished by those doing business with state and local government.
- II. ESTIMATED EFFECT ON REVENUE COLLECTIONS OF STATE OR LOCAL GOVERNMENTAL UNITS (Summary)
No effect on revenue collections. Information required to be provided by the rule is furnished by those doing business with state and local government.
- III. ESTIMATED COSTS AND/OR ECONOMIC BENEFITS TO DIRECTLY AFFECTED PERSONS OR NON-GOVERNMENTAL GROUPS (Summary)
No estimated cost or benefit.
- IV. ESTIMATED EFFECT ON COMPETITION AND EMPLOYMENT (Summary)
Encourage honest competition among financing professionals seeking business with state and local government.

Rae W. Logan
Director

David W. Hood
Senior Fiscal Analyst

POTPOURRI

POTPOURRI

Department of Economic Development Office of Financial Institutions

Judicial Interest Rate—1994

Pursuant to the authority granted by Civil Code Article 2924(B)(3), as amended by Act 774 of 1989 and Act 1090 of 1992, the Commissioner of Financial Institutions has determined the rate of judicial interest for the period beginning January 1, 1994 and ending December 31, 1994 to be 7.0 percent, in accordance with the formula mandated by Article 2924(B)(3).

The terms "prime rate" and "reference rate" shall be deemed synonymous for purposes of this calculation. Prime rate is the rate of interest established by a bank for its most

avored corporate clients in commercial loan transactions.

The "prime rate" or "reference rate" for Chase Manhattan Bank, N.A.; Chemical Bank, which acquired Manufacturers Hanover Trust Company of New York (effective June 22, 1992); Morgan Guaranty Trust Company of New York; Bank of America National Trust and Savings Association; and Citibank, N.A. was reduced to six percent at each institution on July 2, 1992 and has not changed since that date.

Civil Code Article 2924(3)(a) mandates that "[t]he effective judicial interest rate for the calendar year following the calculation date shall be one percentage point above the average prime or reference rate of the five financial institutions named in this Subparagraph or their successors."

The effective judicial interest rate for the calendar year beginning on January 1, 1994 shall be seven percent.

This calculation and its "publication in the *Louisiana Register* shall not be considered rulemaking, within the intentment of the Administrative Procedure Act, R.S. 49:950 et seq., and particularly R.S. 49:953", thus, neither a fiscal impact statement nor a "notice of intent" is required.

Larry L. Murray
Commissioner

POTPOURRI

Department of Economic Development Office of Financial Institutions

Public Hearing—CAPCOs

A public hearing will be held on January 26, 1994, at 9 a.m. at the Office of Financial Institutions, Suite 200, 8401 United Plaza Boulevard, Baton Rouge, LA 70809, regarding substantive changes to a proposed regulation, published in the July 20, 1993 *Louisiana Register*, concerning the supervision of the Louisiana Capital Companies Tax Credit Program.

Interested persons are invited to attend and/or submit oral or written comments on the proposed regulation at that time. Any individual who has a disability or other infirmity which requires special attention in order to participate, should contact Dale Jacobs at the address listed above or directly at (504) 922-0632, no later than January 24, 1994.

Larry L. Murray
Commissioner

POTPOURRI

Department of Health and Hospitals Office of the Secretary Bureau of Health Services Financing

Disproportionate Share Hospital Reimbursement-Indigent Care

The Department of Health and Hospitals, Office of the Secretary, Bureau of Health Services Financing is providing notice that a second public hearing will be held on the notice of intent entitled Additional Disproportionate Share - Indigent Pool which was published in the April 20, 1993 issue of the *Louisiana Register*, Volume 19, No. 4. This public hearing will be held at 9:30, January 25, 1994, Department of Transportation and Development auditorium, 1201 Capitol Access Road, Baton Rouge, LA. The purpose of this public hearing to discuss changes to the above-cited Notice of Intent.

Per the Health Care Financing Administration's recommendations the department's Free Care Plan Criteria for recognition of indigent days in the Indigent Pool for additional disproportionate share payments are delineated below:

1. The annual family income for patients qualifying for free care may not exceed 200 percent of the Federal Poverty Income Guidelines.

2. The facility must advise the public of the availability of free care services and of its policies for qualifying patients for free care. The facility must post a written copy of its policy conspicuously in all patient treatment areas, admissions and provide individual written notices to patients and/or their family members upon admission.

3. The facility must provide a form for individuals to apply for free care services upon admission to the facility. These forms must be maintained on file and be available for audit in accordance with all federal rules and regulations. The application must be signed by the applicant except for patients deemed mentally unstable by the physician and for which access for interview has been restricted by physician's orders. The facility must supply auditors with facility's procedures for verification of available payment sources for such patients.

4. The facility must make a determination of the patient's eligibility for free care services within two working days after application, notify the patient properly of the decision, and keep a copy on file for audit in accordance with federal rules and regulations. Income verification should be attempted via review of pay stubs, W-2 records, unemployment compensation book, or collateral contact with employer etc. If income verification has not been completed within two working days, the facility may condition the determination of eligibility on income verification. The conditional determination must be completed within two working days of the request for free care.

5. The facility must maintain a log of free care services provided each fiscal year for audit purposes in compliance with federal rules and regulations. Patient identifying information such as patient name, social security number, date of birth, dates of service, medical record number, patient

account number, number of free care days, and amount of free care charges must be included on the log.

6. Indigent days may only be included as days in the indigent pool to the extent that the entire day is deemed free care. If free care is determined on a sliding scale which is based on total charges, any day for which the patient is liable for more than 50 percent of the charges may not be considered as free care. Inpatient days denied for Medicaid recipients who had exhausted their Medicaid inpatient days may be recognized as indigent days provided that documentation of the reasons for denial demonstrates that the recipient is over the limit of days. Medicaid days denied for other reasons resulting from failure to comply with Medicaid policies and procedures will not be recognized as indigent days. Prisoners receiving services in state hospitals are deemed indigent in accordance with state law. Inpatient days paid by Medicaid are not recognized as indigent days. Nor are Hill-Burton days that are utilized to meet an obligation under this program recognized as free care days. Medicare bad debt days are not allowable as indigent days. Days for accounts written off as bad debt are not allowable as indigent days.

7. For state-operated facilities a free care plan promulgated and implemented in accordance with state law and regulations shall be recognized for determining indigent days included in the Indigent Pool for disproportionate share payments.

In addition, the provision for permitting annualization of indigent days shall not be implemented.

Rose V. Forrest
Secretary

POTPOURRI

**Department of Health and Hospitals
Office of the Secretary
Bureau of Health Services Financing**

Nursing Facility-Infectious Disease

The Department of Health and Hospitals, Office of the Secretary, Bureau of Health Services Financing is providing notice that a second public hearing will be held on the Notice of Intent entitled Nursing Facility - Infectious Disease - Tuberculosis which was published in the July 20, 1993 issue of the *Louisiana Register*, Volume 19, No. 7. This public hearing will be held at 9 am., January 20, 1994, Department of Transportation and Development auditorium, 1201 Capitol Access Road, Baton Rouge, LA.

The purpose of this public hearing is to discuss the Bureau's changes to the above cited notice of intent. These program changes concern the Bureau's development of an initiative with the Office of Public Health, Tuberculosis Control Section to meet the needs of Louisiana's citizens who require specialized care for the treatment of tuberculosis of the respiratory tract who are sputum positive for the tuberculosis germ and who cannot be treated on an outpatient basis. This meeting will

discuss the specialized patient criteria which will be used to identify the type of patient which qualifies for this program; the specific facility participation requirements which will be used to certify a facility for participation including physical plant, medical, programmatic and reimbursement requirements.

Rose V. Forrest
Secretary

POTPOURRI

**Department of Insurance
Commissioner of Insurance**

Rule 10 Hearing

In accordance with the requirements of Section 10.17 of Rule 10 of the Department of Insurance regulations, the Commissioner of Insurance hereby gives notice that a public hearing will be held on Tuesday, January 25, 1994, regarding whether the rule should remain in effect, be revised, or allowed to expire. The hearing will take place at 1 p.m. in the Plaza Hearing Room of the Insurance Building, 950 North Fifth Street, Baton Rouge, LA. For additional information regarding the hearing, contact C. Noël Wertz or Teri Taylor at (504) 342-8391, (504) 342-0857, respectively.

James H. "Jim" Brown
Commissioner of Insurance

POTPOURRI

**Department of Natural Resources
Office of the Secretary**

Fishermen's Gear Compensation Fund Claims—November

In accordance with the provisions of R.S. 56:700.1 et seq., notice is given that 116 claims in the amount of \$355,675.98 were received in the month of November 1993. Two hundred forty-nine claims in the amount of \$762,503.61 were paid and 3 claims were denied.

Loran coordinates of reported underwater obstructions are:

28287	46826	Lafourche
28008	46842	Terrebonne
29175	46861	Terrebonne
29030	46927	St. Bernard
28627	46867	Plaquemines
28007	46839	Terrebonne
27431	46929	Vermilion
29012	46942	St. Bernard
27927	46836	Terrebonne

POTPOURRI

Department of Social Services
Office of Community Services

Weatherization Assistance Program—Public Hearing

The Department of Social Services, Office of Community Services will submit a State Plan to the U.S. Department of Energy around February 15, 1994 for the Weatherization Assistance Program, pursuant to 10 CFR 440. As a requirement of this plan, a public hearing must be held.

The purpose of the public hearing is to receive comments on the proposed State Plan for the Weatherization Assistance Program for low-income persons, particularly the elderly, handicapped, and children in the state of Louisiana. The public hearing is scheduled for 10 a.m., Thursday, January 27, 1994, 333 Laurel Street, Eighth Floor conference room, Baton Rouge, LA.

Copies of the plan may be obtained prior to the hearing by contacting the Department of Social Services, Office of Community Services, Box 3318, Baton Rouge, LA 70821 or by telephone (504) 342-2272. Interested persons may submit written comments by January 27, 1994 to the Office of Community Services at the above address.

Gloria Bryant-Banks
Secretary

27679	46902	St. Mary
27889	46858	Terrebonne
27735	47884	Terrebonne
27890	46858	Terrebonne
27413	46929	Iberia
29046	46967	St. Bernard
28553	89268	Plaquemines
27735	46884	Terrebonne
28092	46835	Terrebonne
27517	46920	St. Mary
27890	46858	Terrebonne
28154	46821	Terrebonne
27894	46861	Terrebonne
28358	46827	Lafourche
27680	46904	St. Mary
27891	46859	Terrebonne
28589	46862	Jefferson
29078	46804	Plaquemines
26620	46978	Cameron
28588	46849	Jefferson
26649	46975	Cameron
27735	46884	St. Mary
27419	46983	Vermilion
27476	46920	Vermilion
29061	46939	St. Bernard
28324	46823	Lafourche
28810	46839	Plaquemines
27251	46941	Vermilion
28195	46823	Lafourche
28354	46834	Lafourche
29115	46960	St. Bernard
28710	47034	L. Pontchartrain

A list of claimants and amounts paid may be obtained from Martha A. Swan, Administrator, Fishermen's Gear Compensation Fund, Box 94396, Baton Rouge, LA 70804, or by telephone (504) 342-0122.

John F. Ales
Secretary

Jockey equipment, 1509ER
Penalty guidelines, 5ER, 68N
Permitted medication, 5ER, 69N, 119ER, 614R, 1510ER
Two-year-olds, 4ER, 5ER, 68N, 69N, 1510ER

Real Estate Commission

Agency disclosure, 797N, 1128R
Branch Office Supervision, 171R
Out-of-State Broker, 362N, 736R

Used Motor Vehicle and Parts Commission

Identification cards, 1604N
Licensure, 1191N, 1373P
Trade show, 673N, 1021R

EDUCATION

Elementary and Secondary Education, Board of

8(g) Annual Program, 364N, 737R
8(g) Policy Manual, 172R
Administrative Leadership Academy, 801N, 1130R
Adult education, 923N, 1310R
Attendance, 365N, 738R
Complaint Management, 172R, 593ER, 801N, 1131R
Compliance monitoring, 597ER
Deaf School, 279ER, 520N, 845ER, 890R
Dyslexia, 847ER, 1039N, 1286ER, 1395ER, 1417R, 1608N
Employee Grievances, 120ER
Employment permits, 1397ER
Exceptional children, 172R, 594ER, 921N, 1285ER, 1449N
Food/nutrition, 366N, 738R, 1396ER
Food Program 991ER, 1193N, 1549R
Home economics certification, 803N, 1131R
Homeless students, 315R
Honors curriculum, 920N
Language/hearing specialist, 592ER, 800N, 988ER, 1309R
Louisiana Components of Effective Teaching (LCET), 173R
Migrant State Education, 1040N, 1417R
Minimum standards waivers, 6ER, 173R, 739R
Model Career Options Program Guide (MCOP), 120ER
Nonpublic standards, 799N, 845ER
Noncertified personnel, 849ER, 1286ER, 1396ER, 1609N
Parish Superintendents' Advisory Council, 120ER, 726ER, 922N, 1093ER, 1310R
Personnel certification, 801N, 1037N, 1130R
Personnel evaluation, 171R, 739R
Personnel Manual, 316R, 726ER, 846ER, 1092ER, 1606N
Preschool, 597ER, 989ER, 1192N, 1193N, 1396ER, 1548R, 1549R
Pupil appraisal handbook, 171R, 593ER, 920N, 1285ER, 1416R
Pupil Progression, 989ER, 1038N, 1417R
School administrators handbook, 592ER, 988ER, 1037N, 1284ER, 1309R, 1346N, 1416R, 1448N, 1449N
School transportation, 171R, 519N, 890R
Special education, 597ER, 802N, 1131R, 1192N, 1548R, 1605N
Teacher certification, 70N, 71N, 614R, 1416R
Teacher tuition exemption, 993ER, 1094ER, 1451N, 1510ER

Teaching assignments, 1398ER
Temporary assignment, 1606N
Temporary permit, 1606N
Textbook, 594ER, 989ER
Vo-tech
Postsecondary curriculum, 70N, 367N, 614R, 739R, 922N, 1039N, 1309R, 1417R, 1450N
Refunds, 993ER, 1195N, 1397ER, 1550R
Salary schedule, 597ER
Tuition fees, 992ER, 1196N, 1551R
VTIE certification, 1451N
VTIE tuition exemption, 996ER

Proprietary School Commission

Fees, 1197N
Licensure renewal, 173R, 1198N, 1555R, 1556R
Student Protection Fund, 174R, 1198N, 1201N, 1556R, 1559R
Surety bond, 1202N, 1560R
Violations, 372N, 739R

Regents, Board of

Consumer protection, 1097ER, 1196N
Registration/licensure, 1097ER, 1196N, 1551R

Quality Science and Mathematics Council

Grant, 674N, 1021R

Student Financial Assistance, Office of

Electronic funds transfer, 1205N, 1610N
Employment Opportunity Loan Program (LEO), 175R, 676N, 1135R
Honors scholarship, 368N, 727ER, 803N, 1132R
Incentive grant, 804N, 1137R
Late guarantee, 1208N, 1562R
LEO alternative employer, 1208N, 1563R
Loan cancellation, 521N, 1136R
Tuition assistance billing, 38R
Tuition Assistance Plan (TAP), 521N, 677N, 1140R, 1142R
Tuition award, 1101ER, 1209N, 1563R

Systemic Initiatives Program Council

Inservice proposals, 524N

ELECTIONS AND REGISTRATION

Voting equipment, 176R
Voting machine storage/drayage, 175R

ENVIRONMENTAL QUALITY

Air Quality and Radiation Protection, Office of

Air fees, 1373P
Benzene emission (AQ35), 39R
Benzene waste (AQ73), 1613N
Chemical Accident (AQ31), 1614N
Chemical Woodpulp (AQ79), 1209N, 1564R
Comprehensive Toxic Air Pollutant Emission Control Program (AQ71), 527N, 890R

CR—Committee Report

ER—Emergency Rule

L—Legislation

P—Potpourri

PPM—Policy and Procedure Memorandum

EO—Executive Order

FA—Fee Action

N—Notice of Intent

PFA—Proposed Fee Action

R—Rule

EXECUTIVE ORDERS

Emission control
(AQ74), 677N, 927N, 1418R
(AQ85E), 1399ER
(AQ84E), 1399ER

Emission reduction (AQ85), 1615N

Emission standards (AQ60), 184R, 485R

Fee system (AQ76), 929N, 1419R

Fee system (AQ77), 1041N, 1564R

Gasoline storage vessels (AQ79), 1209N, 1564R

Inspection/maintenance, 1264P

Mobile sources (AQ78E), 1403ER

Municipal waste combustors (AQ63), 222N, 615R

Nitrogen oxides (AQ81), 1346N

NORM (NE06), 223N, 624R

Organic compounds (AQ72), 1347N

Ozone attainment, 709P, 709P, 709P

Permit procedures
(AQ66), 176R, 486R
(AQ70), 931N, 1420R

Photochemical monitoring, 972P

Polychlorinated dibenzo-p-dioxins/dibenzofurans
(AQ56), 186R

Radioactive material (NE09), 1348N

Radiation protection (NE03), 1042N, 1421R

Radiation protection (NE07), 1043N, 1421R

Radiation safety requirements (NE08), 1211N

Reasonable further progress (AQ86), 1616N

Reduction inventory, 1264P

Stationary sources (AQ69), 1617N

Toxic air pollutants (AQ62), 45R, 1314R

Toxics emission report, 709P, 1314R

Vapor recovery systems (AQ61), 45R

Volatile Organic Compound (VOC)
Incidental reductions (AQ86E) 1404ER
RFP reductions, 1264P

Waste gas (AQ68) 317R

Legal Affairs and Enforcement, Office of Regulatory Agenda, 1373P

Secretary, Office of

Foreign Hazardous Waste (HW38E), 996ER, 1510ER

Permit processing (OS12), 72N, 487R, 742R

Release notification (OS15), 679N, 1022R

Unauthorized discharges
(OS17), 1211N
(OS17E), 1405ER

Solid and Hazardous Waste, Office of

Foreign hazardous waste (HW38), 1213N, 1510ER

Land Ban Petition (HW37), 186R

Liability requirements (HW31), 486R, 626R

Medical waste (SW06), 932N

Scope/mandatory provisions (SW07), 807N, 1314R,
1421R

Solid Waste (SW05), 187R, 255CR, 255CR, 819P

Standards (SW08), 810N, 1143R

UST Registration (UT05L), 1618N

UST Registration (UT05F), 1619N

Water Resources, Office of

Public notice, 972P

Surface water (WP12), 1620N

EWE 92-84—Establishes the Governor's Advisory and Review
Commission Assistant District Attorneys, 266

EWE 92-85—Establishes the Pan American Commission, 266

EWE 92-86—Establishes the Italian-American Advisory
Commission, 267

EWE 92-87—Hotel Dieu Hospital Purchase Agreement, 268

EWE 92-88—Amends EWE 92-71 (Appropriations Adjustment),
268

EWE 92-89—Amends EWE 92-17 and EWE 92-61 Emergency
Response Commission Membership, 269

EWE 92-90—Amends 92-69, Hazard Mitigation Team
Representatives, 269

EWE 92-91—Amends EWE 92-49, Calcasieu Estuary
Environmental Task Force Membership, 270

EWE 92-92—Directs Flags to be Flown at Half-mast in Respect
of Bishop Stanley Joseph Ott, 270

EWE 92-93—Directs the Public Advisory Committee to Carry
Out Certain Duties and Responsibilities, 270

EWE 92-94—Establishes the Louisiana Historical Records
Advisory Commission, 272

EWE 92-95—Amends EWE 92-30 Advisory Task Force on
Environmental Quality Membership, 273

EWE 92-96—Amends EWE 92-3 and EWE 92-48, the
Governor's Advisory Council on Drug Free Schools
and Communities Membership, 273

EWE 92-97—Establishes the Chapter 2 Advisory Committee
within the Department of Education, 274

EWE 92-98—Authorizes the Secretary of Health and Hospitals
and the Commissioner of Administration to Sign all
Documents for Purchase of Hotel Dieu Hospital in
New Orleans, 274

EWE 92-99—Amends EWE 92-98 to Designate the Louisiana
Health Care Authority to Manage and Operate the
Hotel Dieu Hospital Facility, 275

EWE 92-100—Bond allocation by St. Charles Parish for
Louisiana Power and Light Company, 276

EWE 93-1—Housing Strategies to Accommodate Needs of
Elderly, 276

EWE 93-2—Creates Louisiana D.A.R.E. Advisory Board, 276

EWE 93-3—Creates the Governor's Commission on the Capitol
Lakes Rehabilitation Project, 277

EWE 93-4—Requires Cooperative Endeavor Agreements to be
Approved by the Division of Administration, 278

EWE 93-5—Designates the Division of Administration and the
Department of Public Safety and Corrections to
Manage all Documents Pertaining to Refinancing the
Louisiana Correctional Facilities Corporation, 278

EWE 93-6—Directs All Departments and Agencies within the
Executive Department to Comply with All Provisions
of the Minority Business Enterprise Act, 570

EWE 93-7—Establishes the Governor's Task Force on
Charitable Gaming, 570

EWE 93-8—Creates the Post Secondary Review Commission,

CR—Committee Report

ER—Emergency Rule

L—Legislation

P—Potpourri

PPM—Policy and Procedure Memorandum

EO—Executive Order

FA—Fee Action

N—Notice of Intent

PFA—Proposed Fee Action

R—Rule

57122

- EWE 93-9—Direct Conversion of the State Motor Vehicle Fleet to a Natural Gas Using Fleet, 571
- EWE 93-10—Designates Department of Economic Development as the State Clearinghouse for purposes of LA R.S. 39:9023(F), 722
- EWE 93-11—Bond allocation by St. Charles Parish for Louisiana Power and Light Company, 722
- EWE 93-12—Establish a statewide Minority Arts and Humanity Council to preserve and promote the Afro-American Culture, 723
- EWE 93-13—Bond allocation by LA Public Facilities Authority for St. Joseph Limited Partnership Project, 723
- EWE 93-14—Designates the Department of Agriculture and Forestry as the oversight authority for the forestry and agriculture non-point source pollution management measure of the Coastal Zone Act Reauthorization Amendments of 1990, 723
- EWE 93-15—Establishes the Louisiana Drug Control and Violent Crime Policy Board within the Executive Department of the Office of the Governor, 830
- EWE 93-16—Establishes the Governor's Alternative Fuels Task Force to Develop a Comprehensive State Alternative Fuels and Alternative Fueled Vehicle Program, 830
- EWE 93-17—Creates the Louisiana Retirement Inducement Task Force within the Governor's Office of Elderly Affairs, 831
- EWE 93-18—Travel Reimbursement for Members of the Louisiana Employment Service Advisory Council to Attend Board Meetings, 832
- EWE 93-19—Establishes the Advisory Council on the Child Care and Development Block Grant within the Department of Social Services, 832
- EWE 93-20—Creates the Governor's Statewide Independent Living Council, 1089
- EWE 93-21—Establishes the Louisiana Emergency Response Commission, 1089
- EWE 93-22—Authorizes the Office of Emergency Preparedness to Activate and Deactivate the State Emergency Operations Center, 1090
- EWE 93-23—Amends Section 7 of Executive Order EWE 93-8, 1092
- EWE 93-24—Establishes the Louisiana Medical Benefits Council, 1278
- EWE 93-25—Bond allocation by the Parish of St. Charles for Shell Oil Company of Norco, 1387
- EWE 93-26—Bond allocation by the Parish of East Baton Rouge for Georgia-Pacific Corporation, 1387
- EWE 93-27—Bond allocation by the Parish of Beauregard for Boise Cascade Corporation, 1388
- EWE 93-28—Directs the Department of Transportation and Development to Issue Special Permit to Cotton Module Operators, 1388
- EWE 93-29—Creates the Office of Urban Affairs and Development, 1389
- EWE 93-30—Directs the Military Department, Office of Emergency Preparedness as the Lead Agency and Coordinator for all Emergency and Disaster Preparation, Response and Recovery, 1390
- EWE 93-31—Amends Section 2 of Executive Order EWE 93-7, 1390
- EWE 93-32—Creates the Louisiana Violent Crime and Homicide Task Force, 1390

- EWE 93-33—Amends Executive Order EWE 93-24, 1391
- EWE 93-34—Recreates the Louisiana Small Business Bonding Assistance Program within the Department of Economic Development, 1391
- EWE 93-35—Transfers the Office of Litter Reduction and Public Action, 1394
- EWE 93-36—Directs the Department of Transportation and Development to Issue a Special Harvest Season Permit to Sugarcane Vehicle Operators, 1394
- EWE 93-37—Amends Executive Order No. EWE 93-36, 1504
- EWE 93-38—Establishes a Telecommunication Task Force, 1504
- EWE 93-39—Amends Executive Order No. EWE 93-8, 1505
- EWE 93-40—Bond Allocation by the Port of Iberia District for Certification of Indebtedness, 1505
- EWE 93-41—Bond Allocation by Industrial Development Board of the Parish of Calcasieu, Inc. for CITGO Petroleum Corporation, 1506
- EWE 93-42—Bond Allocation by Industrial District No. 3 of the Parish of West Baton Rouge for Dow Chemical Corporation, 1507
- EWE 93-43—Bond Allocation by the Parish of Natchitoches for Willamette Industries, Inc., 1507
- EWE 93-44—Bond Allocation by the Parish of St. Charles for Louisiana Power & Light Company, 1508
- EWE 93-45—Bond Allocation by the Louisiana Housing Finance Agency for Tall Timbers Apartments, 1508

FIREFIGHTERS' PENSION AND RELIEF FUND

City of New Orleans and Vicinity

Death benefits, 1043N

Trustees, Board of

Direct rollovers, 226N, 742R

Forfeited service credit, 227N, 743R

GOVERNOR'S OFFICE

Administration, Division of

Community Development, Office of

Disaster Recovery, 1286ER, 1354N

LCDBG Program, 188R, 1354N

Contractual Review, Office of

Claims recovery, 1405ER

Facility Planning and Control, Office of

Buildings demolition, 1354N

Capital outlay budget, 1102ER, 1216N

Historic Restoration, 488R

State Land Office

Rules repromulgation, 73N, 489R

State Uniform Payroll

Payroll deduction, 318R

Architects Selection Board

Selection procedure, 1351N

CR—Committee Report

ER—Emergency Rule

L—Legislation

P—Potpourri

PPM—Policy and Procedure Memorandum

EO—Executive Order

FA—Fee Action

N—Notice of Intent

PFA—Proposed Fee Action

R—Rule

Coastal Activities, Office of

Public notice, 973P

Elderly Affairs, Office of

Adult protective service, 327R

Assistance program, 107P

Frail elderly, 604ER, 680N, 1422R

Long-term care, 228N, 627R, 850ER, 1046N, 1423R

State Plan, 730ER, 933N, 998ER, 1317R

Law Enforcement and Administration of**Criminal Justice, Commission on**

Felony sentencing, 280ER, 528N, 892R

Oil Spill Coordinator, Office of

Contingency Fund, 820P

Interagency Council, 1076P

Meetings, 1373P

Patient's Compensation Fund Oversight Board

Annual Report, 204R

Enrollment date, 530N

Surcharge, 1622N

Medical care/related benefits, 1216N, 1566R

Veterans Affairs, Office of

Members, 1352N

Merchant Marine, 1621N

State Aid, 1215N, 1565R

Travel, 1352N

HEALTH AND HOSPITALS**Alcohol and Drug Abuse**

Substance abuse group homes, 346R

Board Certified Social Work Examiners, Board of

Meeting Dates, 225P

Chiropractic Examiners, Board of

Solicitation, 934N

Dentistry, Board of

Adjudications, 934N, 1317R

Complaints, 531N, 938N, 1321R

Dental assistant, 205R

Dental hygienist, 206R

Fees/costs, 207R

Hepatitis B virus/HIV, 207R

Laser use, 333R

Rulemaking, 940N, 1322R

Electrolysis Examiners, Board of

License fees/amendments, 374N, 1144R

Embalmers and Funeral Directors, Board of

Care of remains, 940N, 1423R

Examinations, 257P, 560P, 973P, 1373P

Examination sites, 375N, 744R

Funeral establishments, 1355N

Removal of bodies, 1356N, 1452N

Licensed Professional Vocational Rehabilitation**Counselors, Board of**

Definitions, 1220N, 1569R

License, 1220N, 1569R

Practice, 1220N, 1569R

Management and Finance, Office of

Community/rural care, 710P

Pediatric immunizations, 1406ER

Provider fees, 136ER, 347R, 850ER, 1000ER, 1357N,

1406ER

Rural hospitals, 1512R

Medical Examiners, Board of

Acupuncturists, 334R

Occupational therapy, 340R, 683N, 1144R

Respiratory therapy, 80N, 744R

Nursing, Board of

Disciplinary proceedings, 533N, 1145R

Educational programs, 684N, 688N, 1145R, 1146R

Faculty, 999ER

HBV/HIV, 533N, 1150R

Licensure, 1046N, 1572R

Out-of-state programs, 999ER

Temporary permits, 1046N, 1572R

Nursing Facility Administrators, Board of Examiners of

Continuing education, 681N, 1023R, 1322R

Language clarification, 681N

Preceptor update, 682N, 1023R

Reciprocity license, 683N, 1024R

Optometry Examiners, Board of

Continuing education, 1048N, 1573R

License, 1048N, 1573R

Pharmacy, Board of

Pharmacies, 1024R

Physical Therapy Examiners, Board of

Physical therapist assistant, 208R

Practical Nurse Examiners, Board of

HBV/HIV, 341R

Professional Counselors, Board of Examiners of

Practices/procedures, 1623N

Psychologists, Board of Examiners of

Clinical neuropsychology, 1423R

Continuing education, 46R

Specialty, 941N

Supervision, 942N

Testing/evaluation, 496R

Training/credentials, 945N, 1323R

Public Health, Office of

Death certificate, 1223N, 1575R

Health assessment, 1488P, 1489P

Infants hearing impairment, 955N, 1430R

Newborn congenital syphilis, 1114ER, 1227N, 1575R

Nutrition program, 1265P

Sanitary Code

HIV, 211R

Mechanical wastewater, 49R

Oyster alert, 230N, 643R

Tanning facility, 209R

Tuberculosis Control, 1625N

Radiologic Technology Board of Examiners

Board actions, 1057N, 1433R

Secretary, Office of

Americans with Disabilities Act, 107P

Assets transfer, 1290ER, 1629N

Audiologists, 384N, 754R

Case management, 108P, 1287ER, 1358N

Cholesterol screening, 690N, 1028R

CR—Committee Report**EO—Executive Order****ER—Emergency Rule****FA—Fee Action****L—Legislation****N—Notice of Intent****P—Potpourri****PFA—Proposed Fee Action****PPM—Policy and Procedure Memorandum****R—Rule**

Chronically mentally ill, 6ER, 233N, 644R
 Community Care Program, 137ER, 234N, 645R
 Concurrent Care, 239N
 DHH/LHCA Service Agreement, 1513ER, 1625N
 Developmentally delayed infants/toddlers, 7ER, 648R
 Disproportionate share, 7ER, 281ER, 434ER, 435ER, 436ER, 536N, 711P, 1001ER, 1108ER, 1110ER, 1408ER, 1514ER
 Drug Screening/Certification, 1626N
 Durable medical equipment, 85N, 497R
 EPSDT Program 138ER, 376N, 748R, 957N, 1331R
 Facility need review, 437ER, 749R
 Group health premium, 811N, 1152R
 ICF/MR beds, 139ER, 283ER, 605ER
 ICF/MR facilities, 1627N
 Inpatient psychiatric services, 86N, 282ER, 283ER, 711P
 Solicitation of offers, 1407ER
 Utilization report, 8ER, 733ER
 Hearing date, 424P
 High-risk pregnancy, 9ER, 235N, 645R
 HIV, 18ER, 234N, 645R, 1489P
 Home/community based services, 438ER, 691N, 820P, 1029R
 Hospice services, 378N, 749R
 Hospital licensing, 813N, 1153R
 Hospital services reimbursement, 9ER
 ICF/MR facility residents, 12ER, 236N, 442ER, 645R
 Immunizations, 1288ER
 Indigent care, 1648P
 Infant, toddler, 242N
 Infant mortality, 1631N
 Infectious disease, 1649P
 Informed consent, 1232N, 1581R, 1635N, 1636N
 Inpatient hospital services, 1467N
 Inpatient psychiatric services, 13ER, 379N, 751R, 1111ER, 1111ER, 1228N, 1358N
 KIDMED, 13ER
 LHCA service agreement, 6ER, 48R
 Long-term care, 14ER, 380N, 441ER, 751R, 1077P
 Low-income beneficiaries, 21ER, 241N, 442ER, 647R
 Maternal/child health block grant, 537N, 893R
 Medicaid beneficiaries, 752R
 Medicaid countable resources, 540N
 Medicaid days pool, 541N, 1432R
 Medicaid enrollment centers, 20ER, 232N, 435ER, 644R
 Medicaid estate recovery, 1289ER
 Medicaid providers, 381N, 751R
 Mental health rehabilitation, 14ER, 497R
 Mentally retarded/developmentally disabled, 16ER, 236N 646R
 Narcotics/controlled substances, 257P
 Neurological rehabilitation, 28ER, 139ER, 348R, 439ER, 537N, 893R
 Non-emergency transportation, 17ER, 142ER, 237N, 382N, 646R, 751R
 Nurse aide, 383N, 441ER, 752R, 1002ER, 1229N, 1410ER, 1579R
 Nurse anesthetist, 108P
 Nursing facility, 449R, 712P, 958N, 974P, 1468N
 Pediatric Immunizations, 1628N
 Per diem rate, 19ER
 Perinatal/neonatal, 1374P
 Pharmacy lock-in, 1230N, 1579R

Provider fees, 377N
 Psychiatric hospital
 Reimbursement cap, 19ER
 Reimbursement methodology, 1453N
 Referral/Investigation, 1516ER, 1631N
 Residents' trust fund, 1289ER
 Sickle Cell Anemia, 1452N
 Third-party liability, 108P
 Utilization review, 257P
 Ventilator assisted care, 22ER, 243N, 648R

Substance Abuse Counselors, Board of Certification for
 Revised rules, 120ER, 229N, 627R

Veterinary Medicine, Board of
 Board members, 107P, 1488P
 Complaints, 951N, 1327R
 Conduct, 948N, 1325R
 Continuing education, 1053N, 1427R
 Euthanasia, 1050N, 1423R
 Examination dates, 107P, 973P, 1488P
 Examinations, 949N, 950N, 1326R, 1327R
 Fees, 1055N, 1429R
 License, 343R
 Practice standards, 952N, 1328R
 Preceptorship, 208R
 Public hearings/meetings, 85N, 344R
 Temporary permits, 48R
 Zoo personnel, 1056N, 1429R

INSURANCE

Commissioner of Insurance

Accreditation (Reg 50), 1293ER, 1472N
 Actuarial memoranda (Reg 47), 1410ER, 1469N
 Affirmative Action Plan (Reg 45), 1232N, 1581R
 Billing audit (Reg 49), 1639N
 Chiropractors (Directive 73), 712P
 Claim form (Reg 48), 1291ER, 1470N
 Defense within limits (Reg 41), 542N, 895R
 Group health (Reg 32), 1359N
 Health Ins. Rating; Individual (Reg 51), 1520ER, 1643N
 Health Ins. Rating; Small Group (Reg 52), 1521ER, 1643N
 Hearing (Rule 10), 1649P
 Holding company (Reg 31), 87N, 501R
 Long-term care (Reg 46), 813N, 1153R

JUSTICE

Attorney General, Office of

Open Housing Act, 142ER, 543N
 Riverboat gaming, 284ER, 384N, 851ER, 895R

LABOR

Employment Security, Office of

Weekly benefit, 1077P

CR—Committee Report

ER—Emergency Rule

L—Legislation

P—Potpourri

PPM—Policy and Procedure Memorandum

EO—Executive Order

FA—Fee Action

N—Notice of Intent

PFA—Proposed Fee Action

R—Rule

Labor, Office of

Community Services Block Grant, 1522ER
 JTPA, 861ER, 1114ER, 1233N, 1581R
 Minors employment, 1294ER

Plumbing Board

Licensing/Renewal, 1061N, 1593R
 Master plumber, 389N, 897R

River Port Pilot Commissioners, Board of

Application/license/operations, 1060N

Workers' Compensation, Office of

Dental care reimbursement, 443ER, 546N, 1161R
 Hearing officer, 350R
 Insurance cost containment, 544N, 873ER, 896R, 960N,
 1331R
 Medical reimbursement schedules, 53R, 212R
 Safety requirements, 385N, 754R

LEGISLATION

Administrative Procedure Act, 1072L

LOUISIANA ADMINISTRATIVE CODE UPDATE**Administrative Code Update**

Cumulative
 January 1992 - December 1992, 105
 January 1993 - March 1993, 557
 January 1993 - June 1993, 971
 January 1993 - September 1993, 1371

NATURAL RESOURCES**Conservation, Office of**

Custody transfer, 390N, 758R
 Hearings, 391N, 759R, 820P, 974P, 1374P
 Multiple completions, 398N, 766R
 New pools, 400N, 767R
 Oil/Gas commingling, 401N, 768R
 Oil reports, 403N, 770R
 Rule corrections, 1030R
 Record keeping/report filing, 406N, 773R
 Statewide Order 29-F, 88N, 1360N
 Statewide Order 29-O-1, 1245N
 Tubingless completion, 411N, 777R
 Unit/survey plat, 391N, 759R
 Unit termination, 410N, 776R
 Unit wells, 408N, 775R

Management and Finance, Office of

Computerized public records, 692N, 1031R

Secretary, Office of

Fee assessment, 92N, 501R
 Fishermen's Gear
 Claims, 108P, 109P, 109P, 424P, 425P, 560P,
 974P, 975P, 975P, 1265P, 1266P, 1489P, 1490P,
 1649P

PUBLIC SAFETY AND CORRECTIONS**Alcoholic Beverage Control, Office of**

Beer/wine sampling, 1063N, 1115ER
 Beverage sampling, 1410ER
 Caterer Permit, 301ER, 473ER, 548N, 904R
 Fairs, festivals, 1473N, 1526ER

Special event permits, 1295ER, 1368N
 Prohibited acts, 1296ER, 1474N
 Wholesale dealer, 814N, 1175R

Corrections Services

Adult inmates, 22ER, 243N, 648R
 Juvenile offenders, 1295ER, 1368N

Liquefied Petroleum Gas Commission

Anhydrous Ammonia, 284ER, 547N, 733ER, 898R
 Classes of permits, 547N, 904R

Management and Finance

Copy fees, 244N, 779R

Pardons, Board of

Sex offenders, 1524ER

Parole, Board of

Sex offender, 712P, 1003ER, 1245N

Private Investigator Examiners, Board of

Initial Rules, 960N, 1332R

Secretary, Office of

Compulsory liability, 153ER

State Police, Office of

Bingo, Keno, Raffle, 1644N
 Breath/alcohol ignition device, 245N, 780R, 1411ER
 Hazardous materials transport/motor carrier safety, 351R,
 1369N
 Keno, 1644N
 Pull tabs, 302ER, 548N
 Raffle, 1644N
 Riverboat gaming, 154ER, 473ER, 549N, 873ER, 1176R,
 1412ER
 Towing, recovery, storage, 93N, 502R
 Video gaming, 303ER

PUBLIC SERVICE**Public Service Commission**

General orders, 1374P
 Practices, 1374P

REVENUE AND TAXATION**Income Tax Division**

Inheritance tax, 1474N
 Waiver of notice, 1474N

Research and Technical Services Division

Printing specifications, 815N, 1176R

Sales Tax Division

Automobile rental; use tax, 1526ER, 1644N
 Cleaning services, 1475N
 Leases/rentals, 550N, 1033R
 Sales of services, 1475N
 Sales price, 1475N
 Transportation charges, 1475N

Secretary, Office of

Electronic funds transfer, 694N, 1032R, 1340R
 Filing date, 1248N, 1594R

CR—Committee Report

ER—Emergency Rule

L—Legislation

P—Potpourri

PPM—Policy and Procedure Memorandum

EO—Executive Order

FA—Fee Action

N—Notice of Intent

PFA—Proposed Fee Action

R—Rule

Severance Tax Division

Natural gas severance tax, 560P
Natural gas franchise tax, 1248N
Oilfield site, 1477N

Tax Commission

Ad valorem, 212R, 1412ER, 1478N
Personal property, 1478N
Ratio study (1992), 425P
Stumpage values, 4ER, 611R, 1443N

SOCIAL SERVICES

Community Services, Office of

Block grant state plan, 561P
Central registry, 1479N
Child protection, 94N, 165ER, 503R
Emergency shelter, 257P
FCAP, 1490P
LIHEAP, 975P, 1490P
Weatherization assistance, 110P, 1650P

Family Support, Office of

AFDC program, 351R, 816N, 817N, 969N, 1177R, 1177R, 1340R
Child support, 818N, 1178R, 1527ER
Food stamps, 213R, 303ER, 414N, 552N, 733ER, 783R, 885ER, 905R, 1064N, 1296ER, 1435R
Individual/family grant, 167ER, 213R, 415N, 606ER, 784R
JOBS, 96N, 504R, 817N, 1297ER, 1479N
Refuge assistance, 304ER

Rehabilitation Services, Office of

Independent living, 975P
Personal care attendant, 1065N, 1436R
Policy manual, 1412ER, 1645N
Sign language, 304ER, 305ER, 552N, 554N, 905R, 906R
Supported employment, 214R
Supported living, 214R

Secretary, Office of

Childcare, 249N, 659R, 695N, 696N, 1069N, 1440R
Childcare providers, 415N, 784R, 1034R
Policy consolidation, 1480N

STATE

Secretary, Office of

Executive branch lobbying, 32ER, 167ER

Uniform Commercial Code, Office of

Central registry, 1484N, 1528ER

TRANSPORTATION AND DEVELOPMENT

Aviation and Public Transportation, Office of

Aircraft, airports, pilots, 819N, 1263CR

Compliance Programs, Office of

Minority participation, 99N, 507R

Crescent City Connection Division

Toll exemptions, 1004ER, 1250N, 1251N, 1594R, 1595R

General Counsel, Office of

Outdoor advertising, 1413ER, 1485N
Sunshine Bridge tolls, 352R

Highways, Office of

LOGO signs, 352R

**Professional Engineers and Land Surveyors,
Board of Registration for**

Bylaws, 54R

Certification, registration, permits, 56R

Engineering branches, 416N, 907R

Real Estate, Office of

Disposal fee, 417N, 785R

Relocation/acquisition, 100N, 507R

Sabine River Compact Administration

Meeting, 713P, 1375P

Secretary, Office of

Directional signs, 1252N, 1596R

Flag display, 359R

Utility and Permit Section

Right-of-way, 1645N

Utility operator, 1486N

Weights and Standards, Office of

Litter tickets, 418N

Vehicle overweight violations, 1115ER, 1370N

TREASURY

Bond Commission

Disclosure agreements, 1117ER

Expedited lease review, 103N, 659R

Lines of credit, 1117ER

Multi-family housing, 706N, 1178R

Negotiated transactions, 1646N

Housing Finance Agency

Emergency Home Investment Partnership, 169ER

Home Investment Partnership Program, 555N, 606ER, 908R, 1034R

**State Employees Group Benefits Program,
Board of Trustees of the**

Fee schedule, 509R

Plan document, 215R, 249N, 250N, 786R, 885ER, 1528ER

Pre-existing conditions, 1116ER

Preferred providers (PPO), 1298ER

Rate adjustment, 886ER, 1071N

**State Employees' Retirement System, Board
of Trustees of the**

Deferred Retirement Option Plan (DROP), 1006ER, 1487N

Disability application, 100N, 507R

Trustee election, 101N, 102N, 508R, 508R

Teachers' Retirement System, Board of Trustees of the

Benefit renunciation, 1259N, 1602R

DROP, 1257N, 1601R

Treasurer, Office of

Linked deposit loans, 915N

WILDLIFE AND FISHERIES

Fisheries, Office of

Freshwater Mussel, 510R

Sturgeon, 511R

CR—Committee Report

ER—Emergency Rule

L—Legislation

P—Potpourri

PPM—Policy and Procedure Memorandum

EO—Executive Order

FA—Fee Action

N—Notice of Intent

PFA—Proposed Fee Action

R—Rule

Triploid Grass Carp, 511R

Wildlife, Office of

Wild Louisiana Stamp, 359R, 513R, 660R

Wildlife and Fisheries Commission

Alligator, 33ER, 215R, 887ER, 1260N

Bait dealers, 215R

Black Bass, 34ER, 254N, 361R, 421N, 485ER, 790R,
909R

Cobia, 513R

Commercial fisherman, 1007ER, 1262N, 1262N, 1529ER

Commercial snapper, 421N, 734ER, 1442R

Dealer receipt, 1008ER, 1529ER

Fill Material, 707N, 1341R

Fishing license, 1487N

Furbearer trapping, 1118ER

Hunting regulations, 422N, 909R

Jewfish, 970N, 1299ER, 1442R

King Mackerel, 513R, 1299ER

Menhaden, 58R, 708N, 1179R

Migratory bird, 1006ER

Oyster, 170ER, 306ER, 1007ER, 1413ER

Red Snapper, 34ER, 170ER, 608ER, 1530ER

Shrimp, 306ER, 609ER, 734ER, 887ER, 887ER, 1006ER,
1008ER, 1008ER, 1529ER

Spanish Mackerel, 513R

Spotted Seatrout, 608ER

Terrebonne Barrier Islands, 307ER, 424N, 734ER, 910R

Toledo Bend, 254N, 790R

Trapping season, 307ER

Waterfowl hunting, 1118ER

CR—Committee Report

ER—Emergency Rule

L—Legislation

P—Potpourri

PPM—Policy and Procedure Memorandum

EO—Executive Order

FA—Fee Action

N—Notice of Intent

PFA—Proposed Fee Action

R—Rule

